

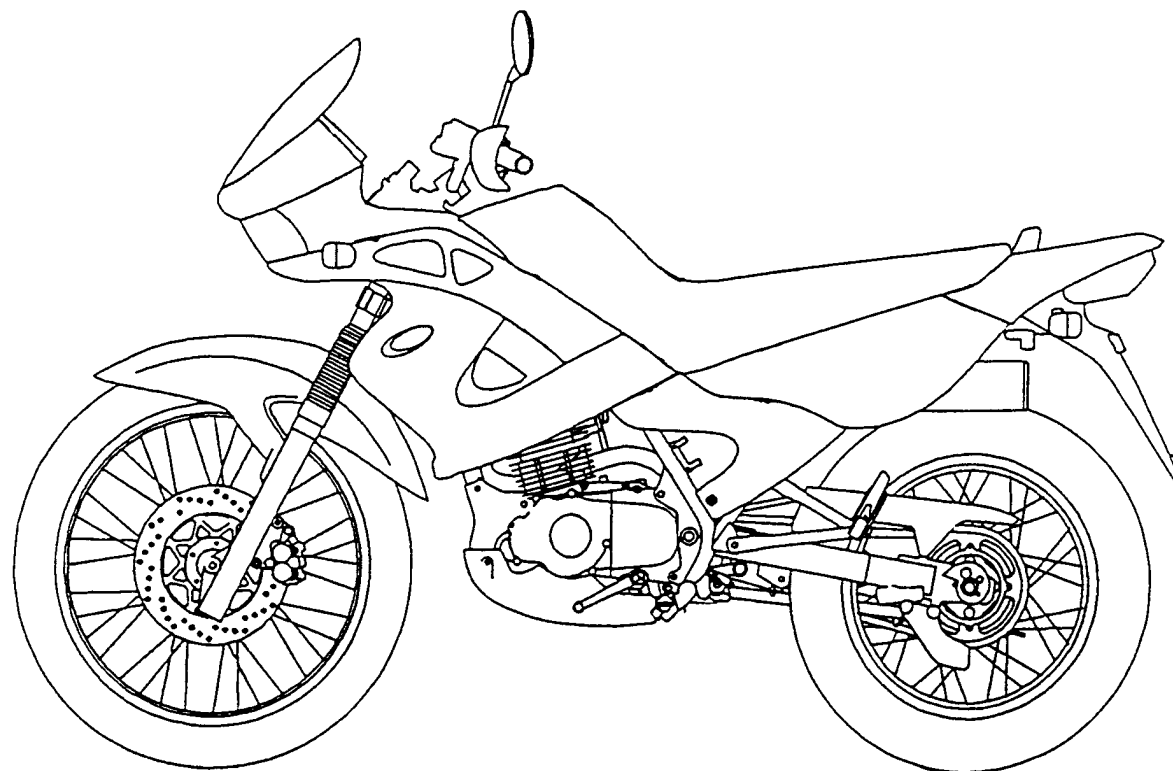

零件型錄

PARTS CATALOGUE

DA25AA(FR) : MAR/12/'99 制定



光陽機車

KYMCO

光陽機車

KYMCO

光陽機車

KYMCO

前 言

- 本零件目錄適用於 DA25AA(FR) 機種，訂購零件時，請參照本冊。
- 本冊之配色表僅供參考，若與實車不符之處，以實車為準。
- 販賣記號(Sales mark)：
 - 1、註明 ★★ 記號，表示訂購該零件時，請參照機車相片及配色表，並請在基本零件號碼最後加上色碼。
 - 2、註明 ★ 記號，表示該零件為補修零件。
- 本冊付梓印刷倉促，倘有錯誤或遺漏之處，敬請不吝賜教指正。

ABOUT THIS PARTS LIST

- This parts list is compiled all service parts for model DA25AA(FR)。
- Any difference between color chart and motorcycle will be revised according to motorcycle。
- The sales mark：
 - 1、marking "★★" must add color code in the end before ordering parts。
 - 2、marking "★" is a saleable item。
- When modification or additions to this parts list are made a revised edition at an appropriate time。

目 次

●前 言	1
●DA25AA(FR)配色表.....	5
●引擎分組圖	7
●車架分組圖	9
●引擎零件號碼表.....	13
●車架零件號碼表.....	47
●零件號碼索引	117

CONTENTS

●ABOUT THIS PARTS LIST.....	1
●COLOR CHART OF DA25AA(FR)	5
●CONTENTS-ENGINE GROUP	7
●CONTENTS-FRAME GROUP	9
●ENGINE PARTS LIST	13
●FRAME PARTS LIST.....	47
●PART NO. INDEX.....	117

項次 NO	機種名稱 (MODEL)			DA25AA(FR) COLOR CHART		
	相片號碼 (PHOTO NO)			NO.1	NO.2	NO.3
	主體色 (BASIC COLOR)			黃	藍	亮紅
	色碼 (CODE)			Yellow	Blue Metallic	Bright Red
	色別零件名稱(PARTS NAME)	基本零件號碼(PARTS NO)	版數(VERSION)	YR108SPA	PB023MPA	RR136PPA
1	COVER UPPER FR	64301-KEC8-9000	0	YR108SP	PB023MP	RR136PP
2	FENDER FR	61110-KEC8-9000	0			
3	COVER R SIDE	64304-KEC8-9000	0	YR108P	NH045P	NH045P
4	COVER L SIDE	64305-KEC8-9000	0			
5	COVER R BODY A	83500-KEC8-9000	0			
6	COVER L BODY A	83600-KEC8-9000	0			
7	COVER R BODY B	83510-KEC8-3050-GM	0			
8	COVER L BODY B	83610-KEC8-3050-GM	0			
9	COVER R FR	64302-KEC8-9000	0	PP116R	NH001R	NH001R
10	COVER L FR	64303-KEC8-9000	0			
11	COWL R UNDER	77115-KEC8-3050-GM	0	NH045P	PB023P	RR136P
12	COWL L UNDER	77116-KEC8-3050-GM	0			
13	CARRIER RR	81200-KEC8-9000	0			
14	LID RR CARRIER	81210-KEC8-9000	0			
15	COVER UNDER	50613-KEC8-9000	0	PP116R	NH001R	NH001R
16	SEAT ASSY	77200-KEC8-9000	0	TYPE B	TYPE A	TYPE A
17	CALIPER ASSY FR	45200-KEC8-9000	0	NH126A	NH126A	NH126A
18	STRIPE R COWL	86103-KEC8-E000-GM	0	TYPE A	TYPE B	TYPE C
19	STRIPE L COWL	86133-KEC8-E000-GM	0			
20	STRIPE B R COWL	86113-KEC8-E000-GM	0			
21	STRIPE B L COWL	86143-KEC8-E000-GM	0			
22	STRIPE R BODY COVER	86423-KEC8-E000-GM	0			
23	STRIPE L BODY COVER	86443-KEC8-E000-GM	0			
24						
25						
26						
27						
28						
29						
30						
31						
32						
33						
34						
35						
36						
37						
38						
39						
40						
41						
42						
43						
生產日期 (DATE OF STARTING-SALES)				1999.FEB.22		1999.MAR.01
停產日期 (DATE OF ENDING-SALES)						

CONTENTS-ENGINE GROUP

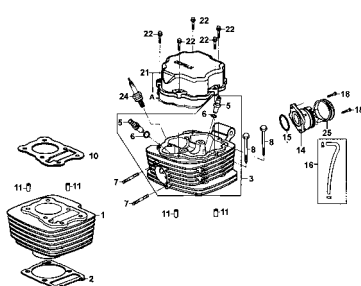
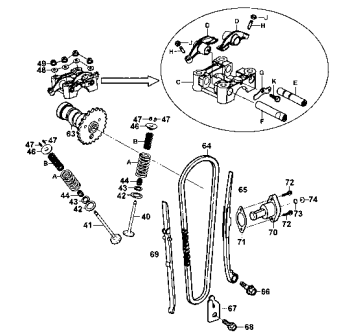
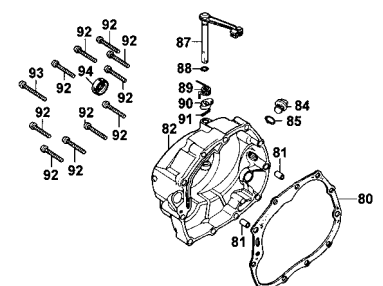
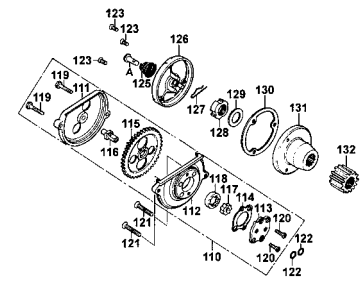
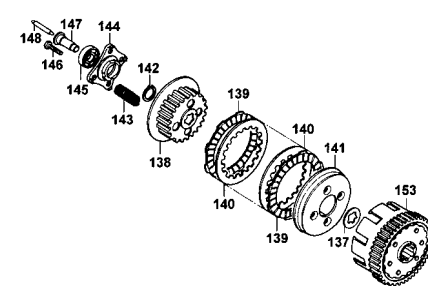
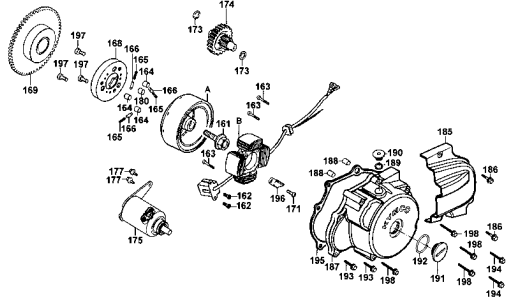
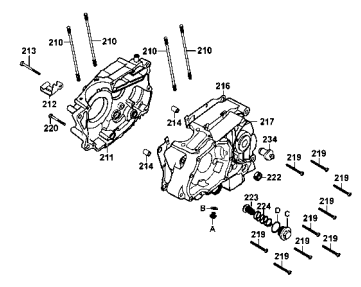
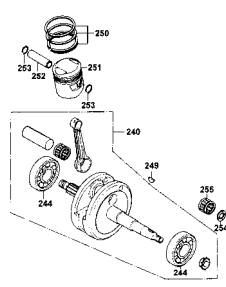
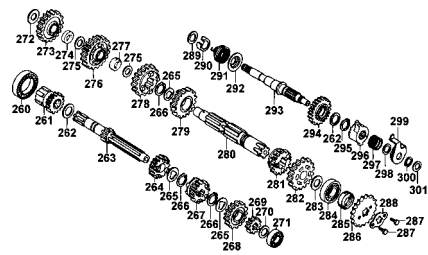
E1 Cylinder Cylinder Head -15-	E2 Valve -17-	E3 Right Crankcase cover -21-
		
E4 Oil Pump -23-	E5 Clutch -27-	E6 Generator Starting Motor -29-
		
E7 Crankcase -33-	E8 Crankshaft Piston -35-	E9 Transmission Kick Starter -37-
		

CONTENTS-ENGINE GROUP

**E10 Gearshift Drum
Gearshift Spindle -43-**

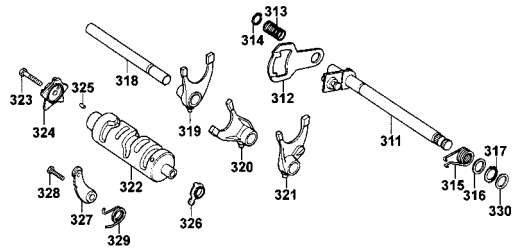

E11 Carburetor -45-

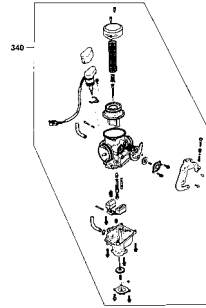

CONTENTS-FRAME GROUP

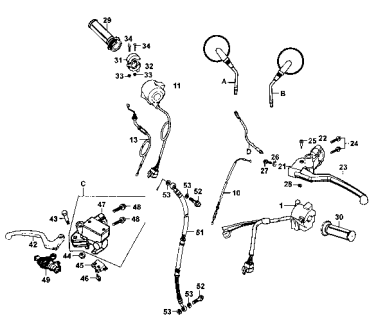
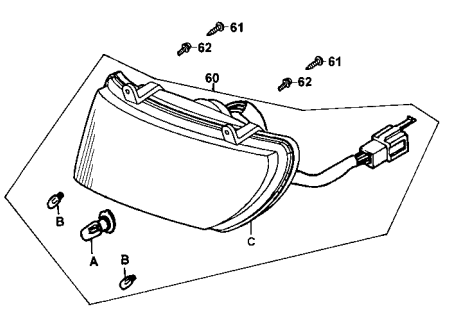
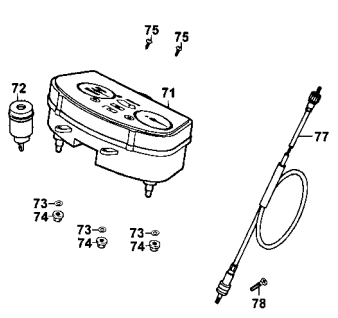
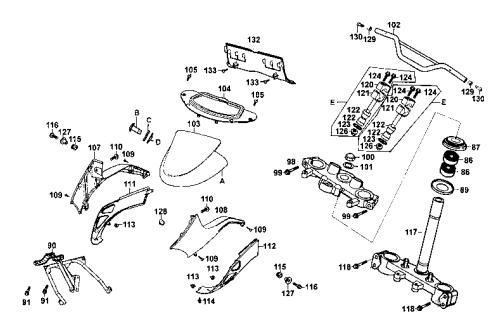
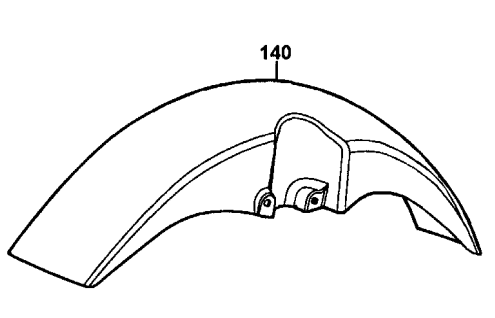
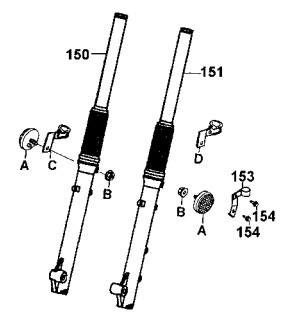
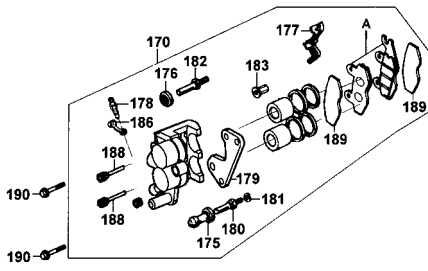
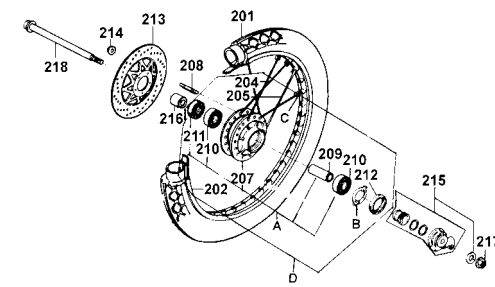
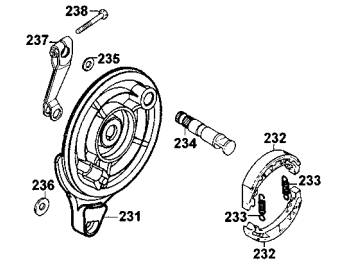
F1 Cable Switch Handle Lever -49-	F2 Head Light -53-	F3 Speedometer -55-
		
F4 Steering Handle -57-	F5 Front Fender -63-	F6 Front Fork -65-
		
F7 Front Caliper -67-	F8 Front Wheel -69-	F9 Rear Brake Panel -71-
		

CONTENTS-FRAME GROUP

F10 Rear Wheel

-73-

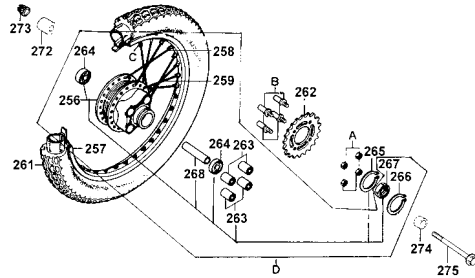

F11 Fuel Tank Fuel Meter

-75-

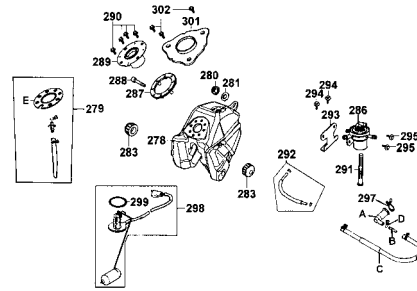

F12 Seat

-79-

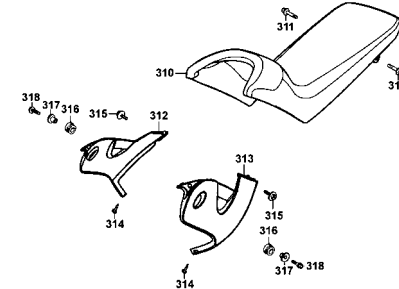

F13 Side Cover

-81-

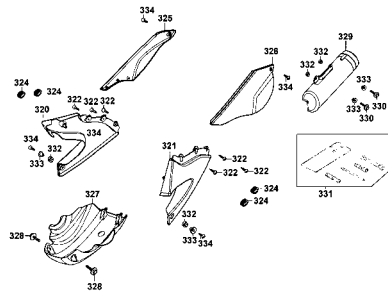

F14 Air Cleaner

-83-

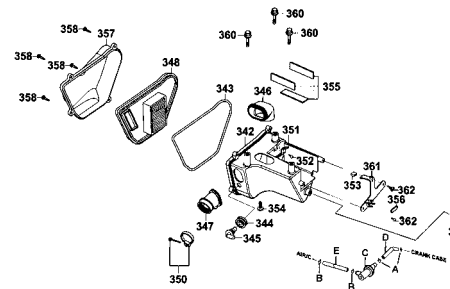

F15 Exhaust Muffler

-87-

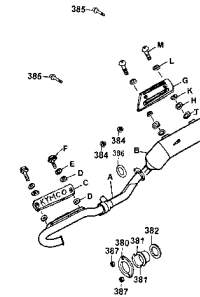

F16 Pedal

-89-

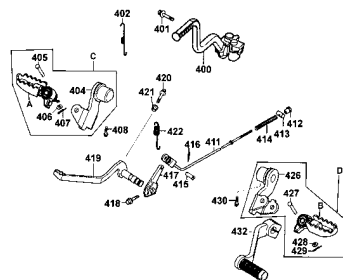

F17 Rear Fork Chain Case

-93-

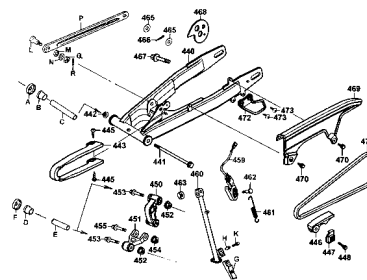

F18 Rear Cushion

-99-

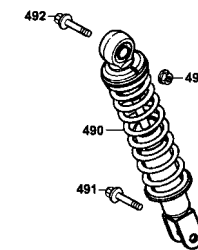

CONTENTS-FRAME GROUP

F19 Rear Fender

-101-

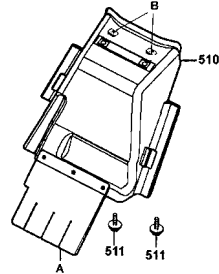

F20 Winker

-103-

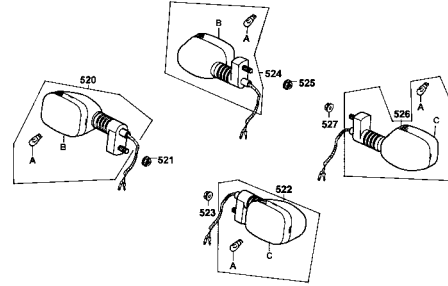

F21 Tail Light

-105-

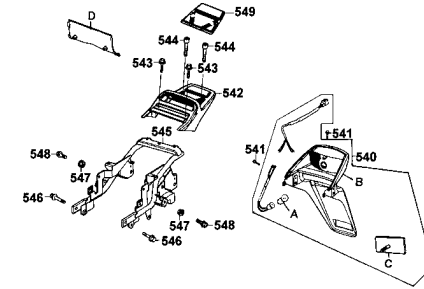

F22 Wire Harness

-107-

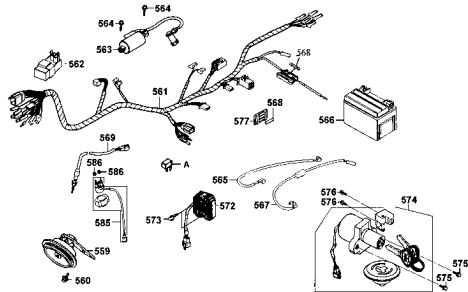

F23 Frame Body

-111-

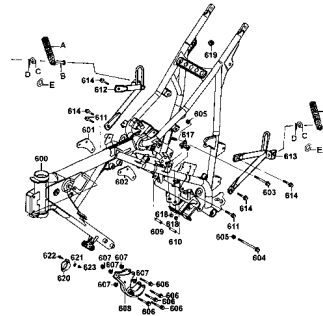

F24 Caution Label

-115-

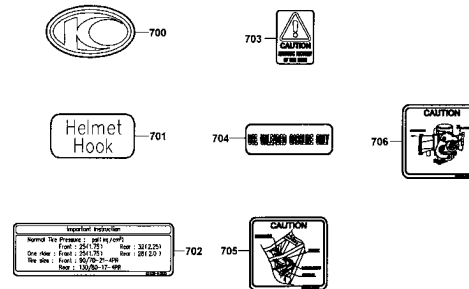

F25 Emblem Stripe

-117-

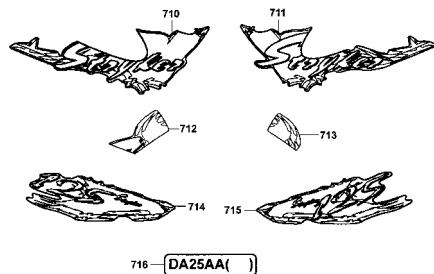

E 1 Cylinder●Cylinder Head

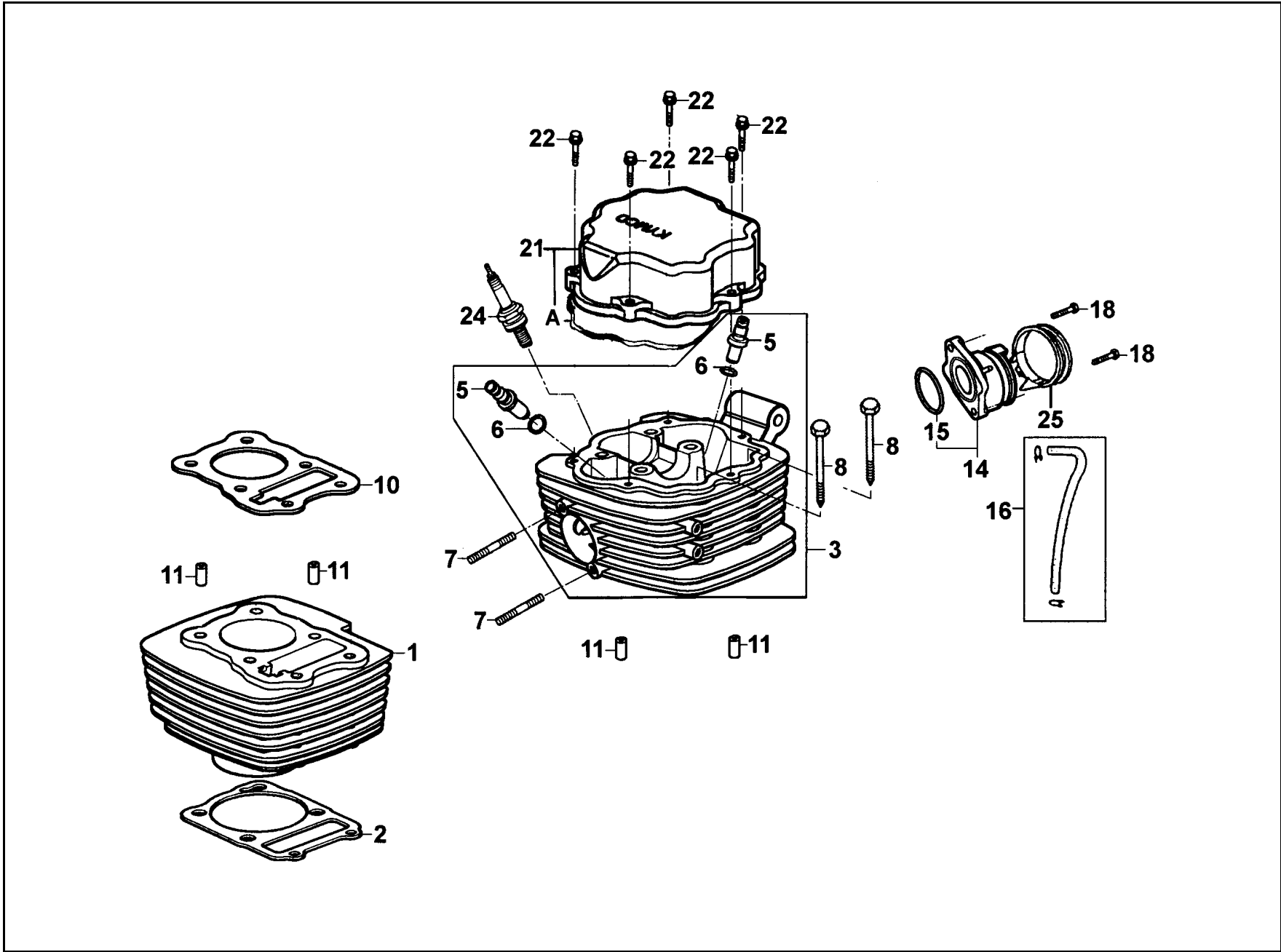

販賣記號	項目	零件號碼	版數	英文名稱	中文名稱	需要用量	參考價
Sales mark	Ref no	Part no	Ver	Description	Chinese	Regd no	Ref Price
*	1	12100-KEC8-9000	0	CYLINDER COMP	汽缸	1	
*	2	12191-KEC8-9000	0	GASKET CYLINDER	汽缸墊片	1	
*	3	12200-KEC8-E000	0	HEAD COMP CYLINDER	汽缸頭	1	
	5	12206-KCS-6500-H1	0	GUIDE EXHAUST VALVE	排氣門導管	2	
*	6	91301-200-0010	0	O-RING 10*1.6	O環 10X1.6	2	
*	7	92700-06035-3E	0	BOLT STUD 6*35	雙頭螺絲 6X35	2	
*	8	96001-06110-08	0	BOLT FLANGE SH 6*110	螺絲 6X110	2	
*	10	12251-KEC8-9000	0	GASKET CYLINDER HEAD	汽缸頭墊片	1	
*	11	94301-10160	0	PIN DOWEL 10*16	定位銷 10X16	4	
*	14	16210-KEC8-E100	0	INSULATOR CARB COMP	汽化器絕緣管	1	
*	15	91302-200-0010	0	O-RING 33.5*3	O環 33.5X3	1	
*	16	9500B-KEC8-9000	0	TUBE ASSY COCK-INLET PIPE	進氣管	1	
*	18	96001-06016-08	0	BOLT FLANGE SH 6*16	螺絲 6X16	2	
*	21	1231A-KEC8-9000	0	COVER CYLINDER HEAD	汽缸頭蓋	1	
*	22	95701-06028-08	0	BOLT FLANGE 6*28	螺絲 6X28	5	
*	24	98069-5771R	0	PLUG SPARK (DR8EA)	火星塞	1	
*	25	17256-GY6-9010	3	BAND INSULATOR	管夾	1	
*	A	12391-KEC8-9000	0	PACKING CYLINDER HEAD	汽缸頭蓋墊片	1	

E 1

E 2 Valve

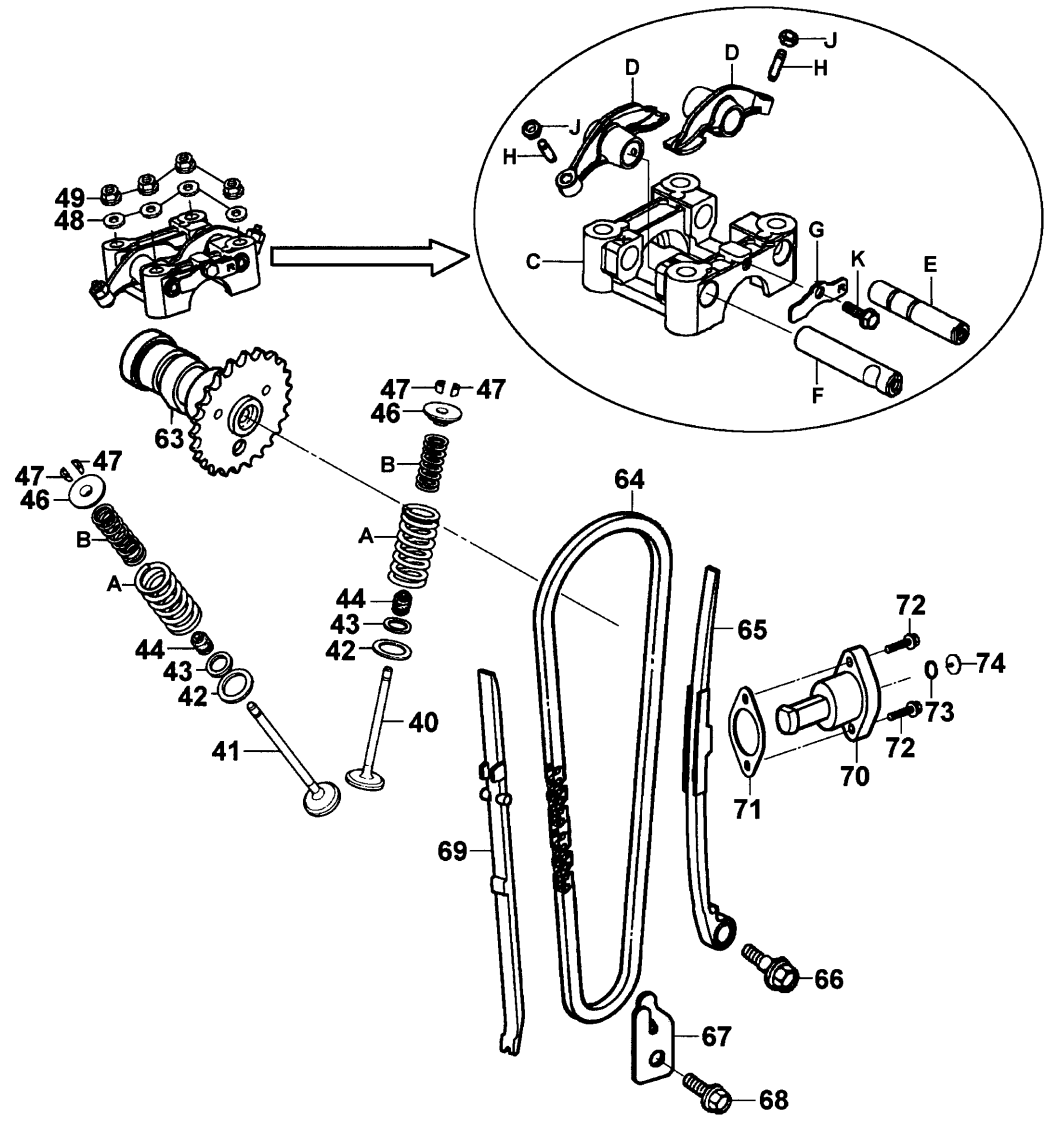

販賣記號	項目	零件號碼	版數	英文名稱	中文名稱	需要用量	參考價
Sales mark	Ref no	Part no	Ver	Description	Chinese	Regd no	Ref Price
*	40	14711-383-0000	0	VALVE INLET	進氣門閥	1	
*	41	14721-383-0000	0	VALVE EXHAUST	排氣門閥	1	
*	42	14775-107-0000	1	SEAT VALVE SPRING OUTER	汽門外彈簧座	2	
*	43	14776-107-0100	1	SEAT VALVE SPRING INNER	汽門內彈簧座	2	
*	44	12208-413-0030	0	SEAL VALVE STEM	門閥徑封	1	
*	46	14771-107-0200	2	RETAINER VLV SPG	門閥彈簧扣環	2	
*	47	14781-107-0200	1	COTTER VALVE	閥門鎖扣	4	
*	48	90465-MC4-0010	0	WASHER 8MM	華司 8MM	4	
*	49	94050-08080	0	NUT FLANGE 8MM	螺帽 8MM	4	
*	63	14100-KEC8-9000	0	CAM SHAFT COMP	凸輪軸	1	
*	64	14401-KEC8-9000-M1	0	CHAIN CAM	內鏈條	1	
*	65	14510-KEC8-9000	0	TENSIONER CAM CHAIN	鏈條拉力桿	1	
*	66	14531-KJ9-0010	0	PIVOT CAM CHAIN TENSIONER	拉力桿螺絲	1	
*	67	14402-KEC8-9000	0	PLATE SET CAM CHAIN	鏈條固定座	1	
*	68	96001-06012-08	0	BOLT FLANGE SH 6*12	螺絲 6MM	1	
*	69	14610-KEC8-9000	0	GUIDE COMP CAM CHAIN	鏈條導片	1	
*	70	14520-GY6-9010-M1	1	LIFTER ASSY TENSIONER	鏈條調整器	1	
*	71	14523-GY6-9000	0	GASKET TENSIONER LIFTER	鏈條調整器墊片	1	
*	72	90001-GHB-6610	0	BOLT FLANGE SH 6*22	螺絲 6X22	2	
*	73	91306-105-6910	0	O-RING 1.5*9.5	O環 1.5X9.5	1	

販賣記號	項目	零件號碼	版數	英文名稱	中文名稱	需要用量	參考價
Sales mark	Ref no	Part no	Ver	Description	Chinese	Regd no	Ref Price
*	74	90005-KW1-9010	0	SCREW PAN 6*6	螺絲 6X6	1	
*	A	14751-KEC8-9000	0	SPRING VALVE OUTER	門閥外彈簧	2	
*	B	14761-KEC8-9000	0	SPRING VALVE INNER	門閥內彈簧	2	
*	C	12211-KEC8-9000	1	HOLDER CAM SHAFT	凸輪軸固定座	1	
*	D	14431-KEC8-9000	1	ARM VALVE ROCKER	門閥搖臂	2	
*	E	14451-KEC8-9000	1	SHAFT IN ROCKER ARM	進汽門閥搖臂輪	1	
*	F	14452-KEC8-9000	0	SHAFT EX ROCKER ARM	排汽門閥搖臂輪	1	
*	G	14453-KEC8-9000	0	SET PLATE ROCKER ARM SHAFT	門閥搖臂輪固定板	1	
*	H	90012-415-0010	0	SCREW TAPPING ADJUSTING	汽門間隙調整螺絲	2	
*	J	90206-250-0010	0	NUT TAPPET ADJUSTING	汽門間隙調整螺帽	2	
*	K	96001-06016-08	0	BOLT FLANGE 6*16	螺絲 6*16	2	

E 2 Valve

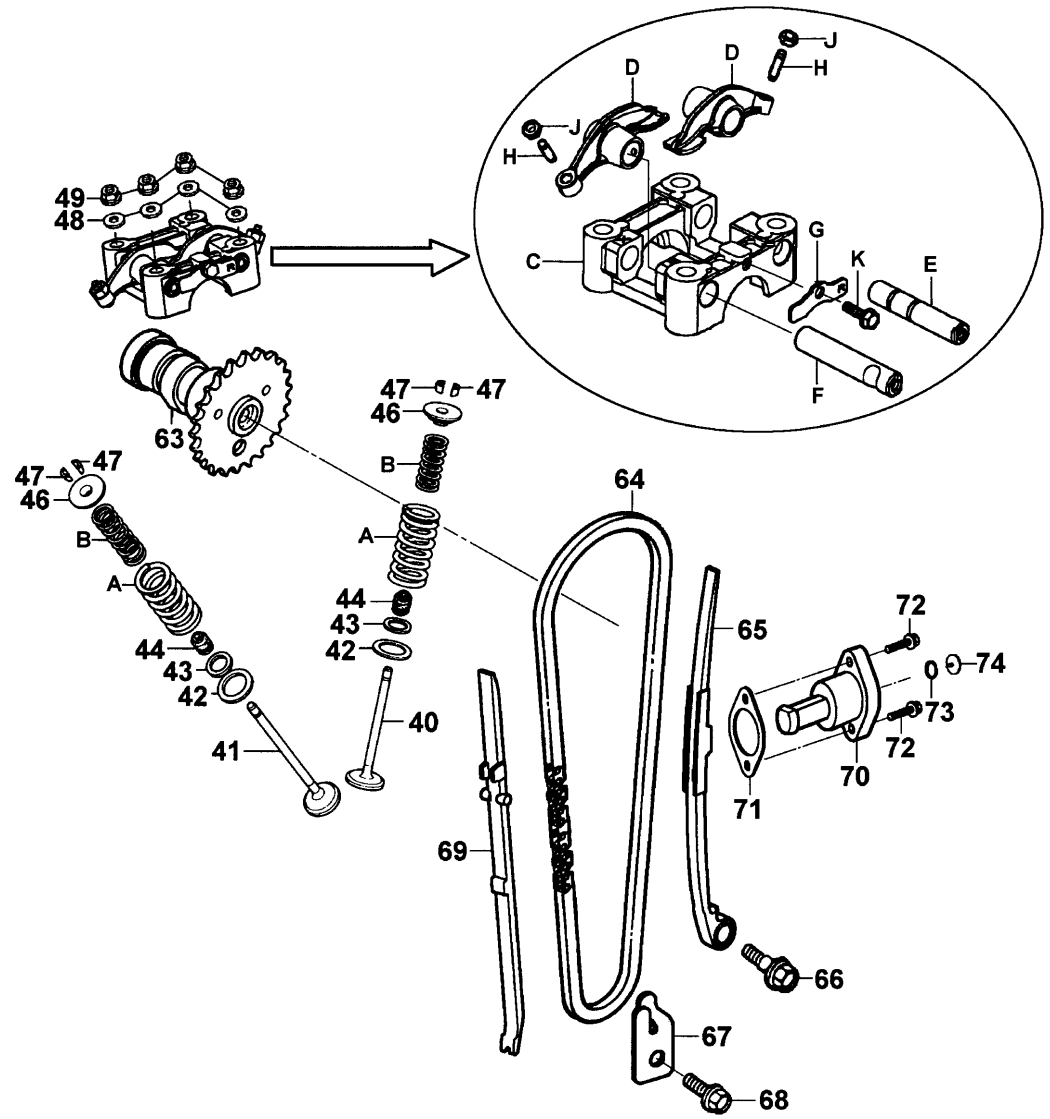

E 3 Right Crankcase Cover

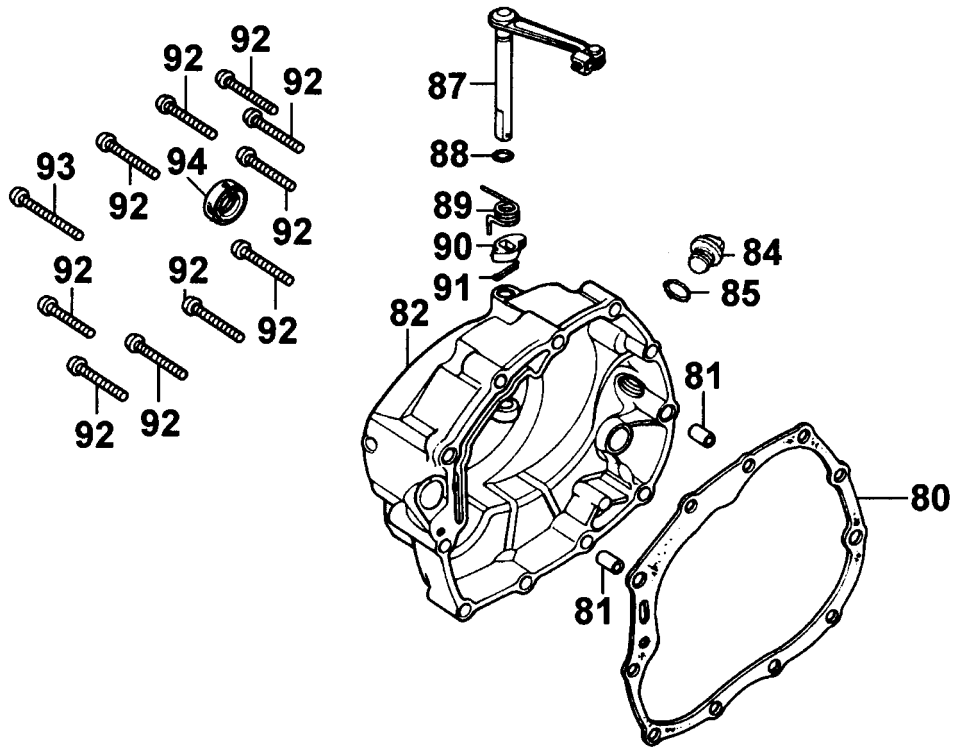

販賣記號	項目	零件號碼	版數	英文名稱	中文名稱	需要用量	參考價
Sales mark	Ref no	Part no	Ver	Description	Chinese	Regd no	Ref Price
*	80	11393-107-0210	0	GASKET RIGHT CRANK CASE COVER	右曲軸箱蓋墊片	1	
*	81	94301-08140	0	PIN A DOWEL 8*14	定位銷 8X14	2	
*	82	11330-KEC8-9000	0	COVER COMP R CRANK CASE	右曲軸箱蓋	1	
*	84	15650-KAK-9000	0	GAUGE OIL LEVEL	量油尺	1	
*	85	91307-035-0010	0	O RING 18*3	O環 18X3	1	
*	87	22810-365-0010	0	LEVER COMP CLUTCH	離合器拉桿	1	
*	88	91301-027-0000	2	O-RING 6.8*1.9	O環 6.8X1.9	1	
*	89	22816-355-0000	1	SPRING CLUTCH LEVER	彈簧	1	
*	90	22821-355-0010	0	CAM CLUTCH LIFTER	拉桿舉升凸輪	1	
*	91	94201-20150	0	PIN SPLIT 2*15	開口銷 2X15	1	
*	92	96001-06040-08	0	BOLT FLANGE 6*40	螺絲 6X40	10	
*	93	96001-06050-02	0	BOLT FLANGE 6*50	螺絲 6X50	1	
*	94	91204-259-0060	0	OIL SEAL 16*28*7	油封 16X28X7	1	

E 4 Oil Pump

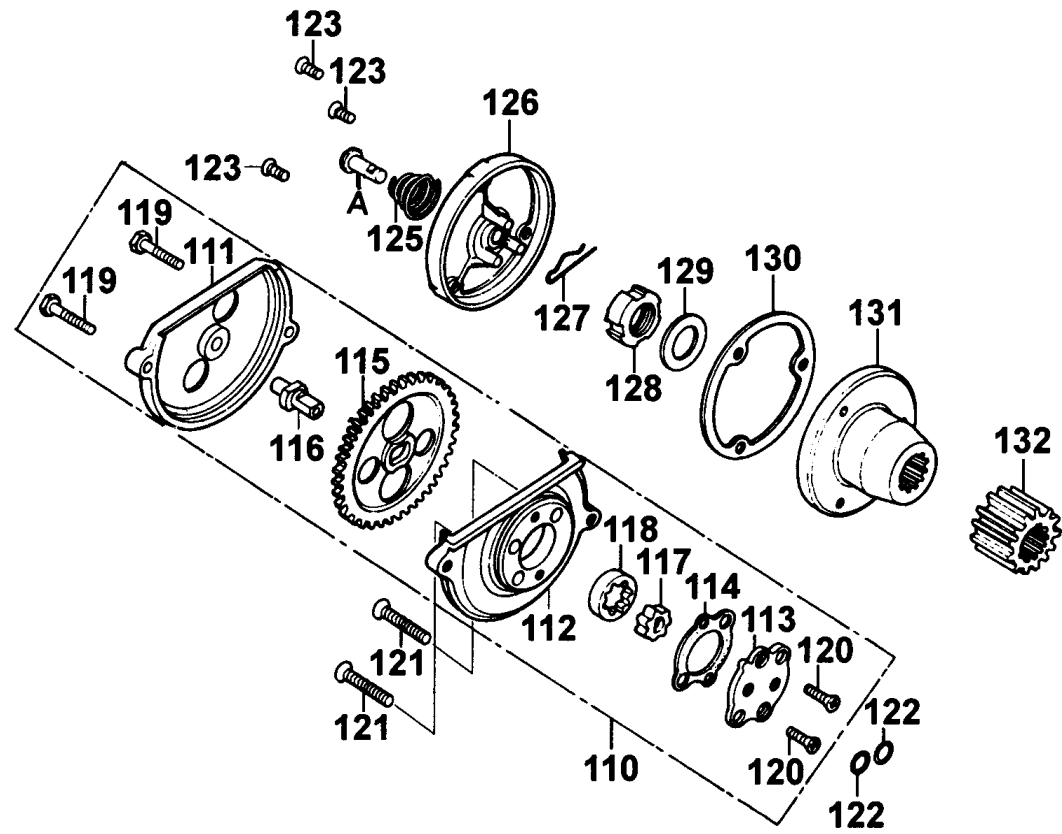

販賣記號	項目	零件號碼	版數	英文名稱	中文名稱	需要用量	參考價
Sales mark	Ref no	Part no	Ver	Description	Chinese	Regd no	Ref Price
*	110	15100-KAK-9000	0	OIL PUMP ASSY	機油泵浦組	1	
	111	15106-330-0100	0	COVER OIL PUMP GEAR	機油泵齒輪蓋	1	
	112	15111-440-0100	0	BODY OIL PUMP	機油泵本體	1	
	113	15116-107-0200	0	PLATE OIL PUMP	機油泵平板	1	
	114	15126-107-0020	1	GASKET OIL PUMP	機油泵墊片	1	
*	115	15131-KAK-9000	0	GEAR OIL PUMP DRIVE	機油泵齒輪	1	
	116	15136-383-0000	0	SHAFT OIL PUMP	機油泵齒輪軸	1	
	117	15331-399-0000	0	INNER ROTOR PUMP	機油泵內轉子	1	
	118	15332-399-0000	0	OUTER ROTOR PUMP	機油泵外轉子	1	
	119	92000-05020-0H	0	BOLT HEX 5*20	螺絲 5X20	2	
	120	93600-04012-1G	0	SCREW FLAT 4*12	螺絲 4X12	2	
*	121	90101-440-0000	0	SCREW FLAT 6*30	螺絲 6X30	2	
*	122	91304-107-0010	0	O-RING 9.4*2.4	O環 9.4X2.4	2	
*	123	93700-05012-0H	0	SCREW OVAL 5*12	螺絲 5X12	3	
*	125	15446-107-0000	0	SPRING OIL THROUGH	通油器彈簧	1	
*	126	15436-107-0000	1	CAP OIL FILTER ROTOR	轉子蓋	1	
*	127	94251-08000	0	PIN LOCK 8MM	螺銷 8MM	1	
*	128	90231-200-0110	0	NUT LOCK 16MM	螺帽 16MM	2	
*	129	15451-107-0000	0	WASHER LOCK OIL FILTER ROTOR	華司	1	
*	130	15459-107-0000	0	GASKET OIL FILTER ROTOR CAP	轉子墊片	1	

E 4 Oil Pump

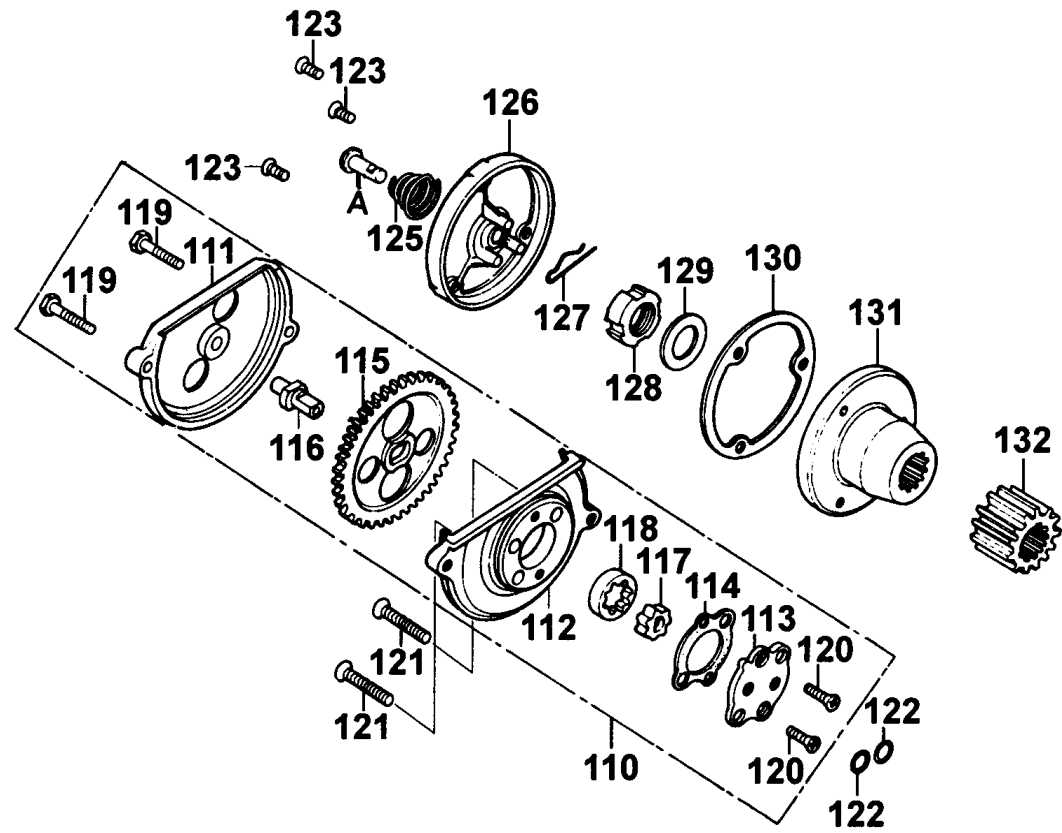

E 4

販賣記號	項目	零件號碼	版數	英文名稱	中文名稱	需要用量	參考價
Sales mark	Ref no	Part no	Ver	Description	Chinese	Regd no	Ref Price
*	131	15430-440-0300	0	ROTER COMP OIL FILTER	轉子	1	
*	132	23121-383-0000	2	GEAR PRIMARY DRIVE (18T)	驅動初齒輪	1	
*	A	15441-107-0000	0	OIL THROUGH	通油器	1	

E 5 Clutch

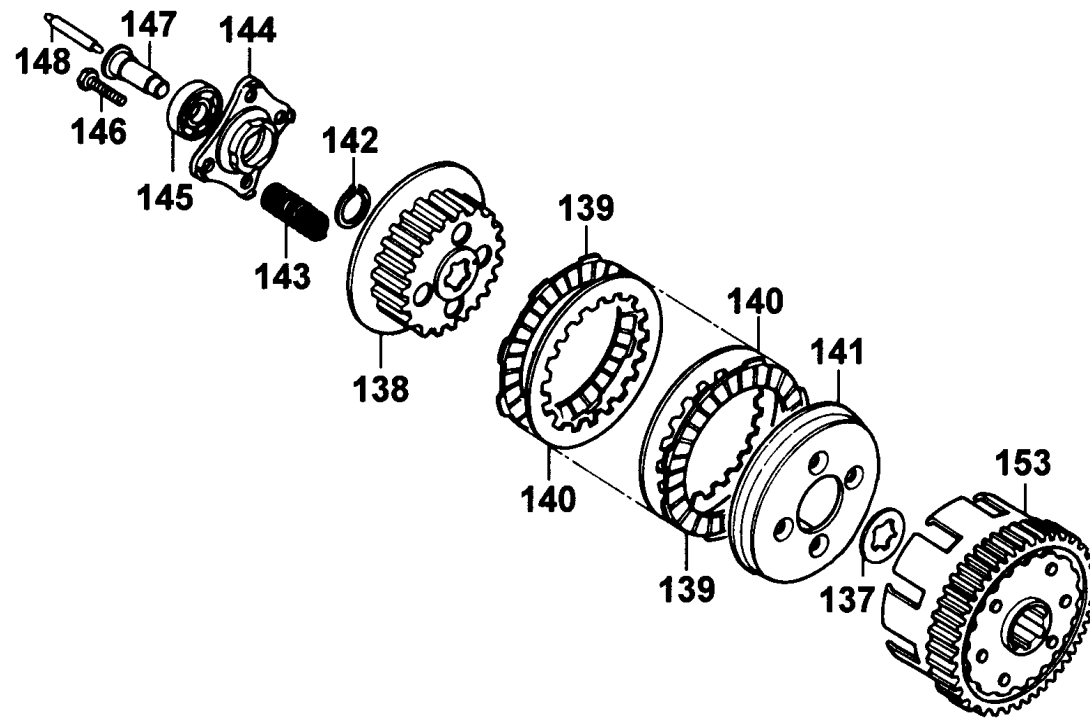

販賣記號	項目	零件號碼	版數	英文名稱	中文名稱	需要用量	參考價
Sales mark	Ref no	Part no	Ver	Description	Chinese	Regd no	Ref Price
*	137	90461-107-0010	0	WASHER SPLINE 20MM	華司 20MM	1	
*	138	22350-107-0120	4	PLATE CLUTCH PRESSURE	離合器壓力板	1	
*	139	22201-KAK-9000	0	DISK CLUTCH FRICTION	離合器摩擦板	4	
*	140	22311-107-0000	2	PLATE CLUTCH	離合器板	4	
*	141	22121-107-0110	2	CENTER CLUTCH	離合器中心	1	
*	142	94510-20000	0	CIR CLIP 20MM	外環夾 20MM	1	
*	143	95014-75110	0	SPRING CLUTCH	離合器彈簧	4	
*	144	22361-107-0010	0	PLATE CLUTCH LIFTER	離合器舉升板	1	
*	145	96100-60010-00	0	BEARING RADIAL BALL 6001	軸承 6001	1	
*	146	95701-06022-08	0	BOLT FRANGE 6*22	螺絲 6X22	4	
*	147	22366-383-0010	0	GUIDE PIN CLUTCH LIFTER	舉升板導銷	1	
*	148	22850-355-0010	0	ROD CLUTCH LIFTER	離合器舉升連桿	1	
*	153	22100-324-0010	3	OUTER COMP CLUTCH	離合器外套	1	

E 6 Generator Starting Motor

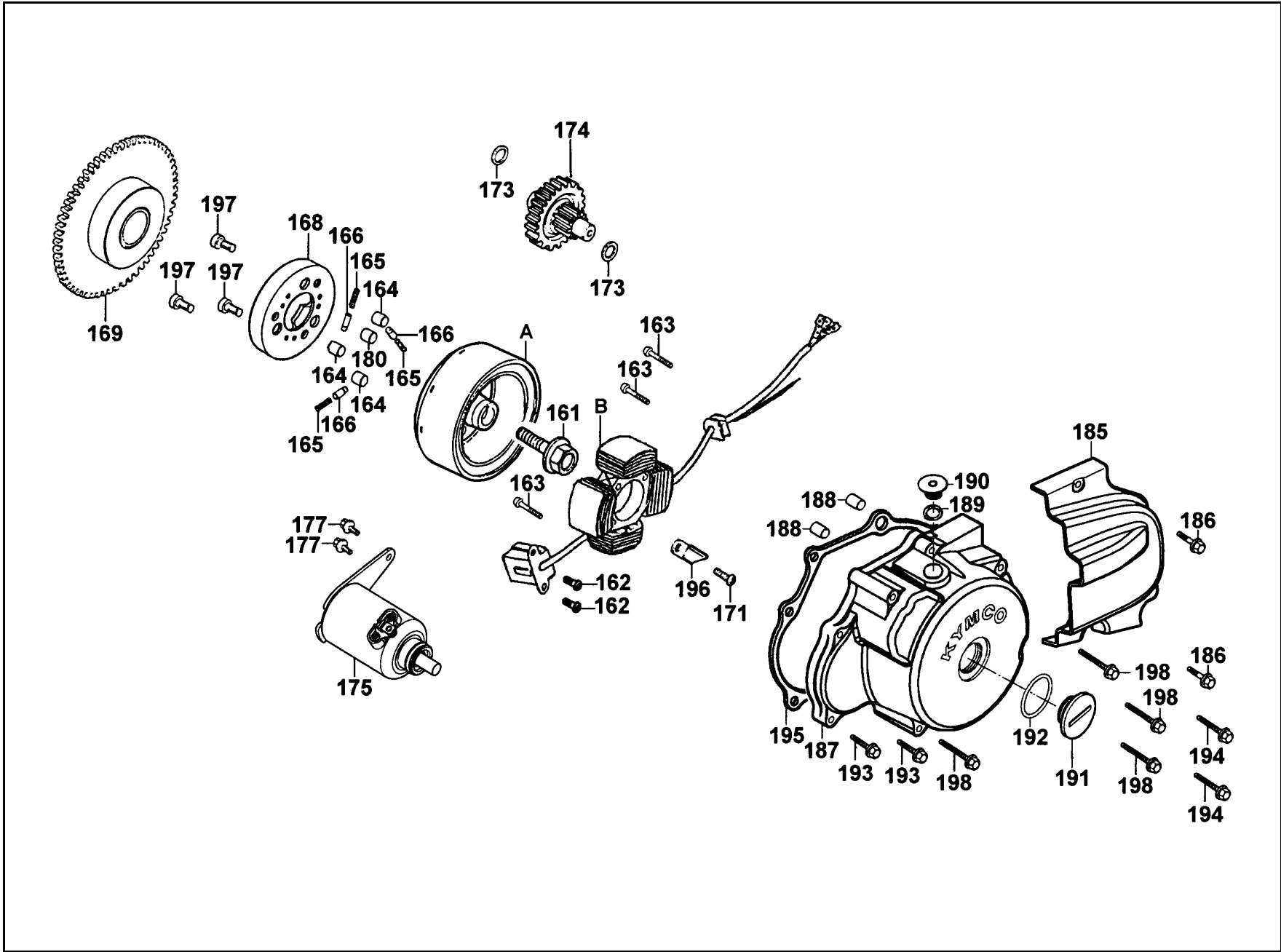

販賣記號	項目	零件號碼	版數	英文名稱	中文名稱	需要用量	參考價
Sales mark	Ref no	Part no	Ver	Description	Chinese	Regd no	Ref Price
*	161	90023-KG7-0010	0	BOLT ROTOR SETTING	螺絲	1	
*	162	93500-05016-0H	0	SCREW PAN 5*16	螺絲 5X16	2	
*	163	92201-05025-0H	0	BOLT HEX 5*25	螺絲 5X25	3	
*	164	91101-179-7110-M1	0	ROLLER 10*10	滾子 10X10	3	
*	165	28125-426-0000	0	SPRING ROLLER STARTER CLUTCH	離合器滾子彈簧	3	
*	166	28126-323-9000	0	CAP STARTING ROLLER SPRING	滾子彈簧蓋	3	
*	168	28120-GY6-9600	2	OUTER COMP STARTING CLUTCH	離合器外套	1	
*	169	28110-KEC8-9000	0	GEAR COMP STARTING DRIVEN	起動小齒輪	1	
*	171	96001-06012-08	0	BOLT FLANGE SH 6*12	螺絲 6X12	2	
*	173	90474-147-0010	0	WASHER 10.5MM	華司 10.5MM	4	
*	174	31241-KEC8-9000	0	SHAFT STARTER GEAR	起動齒輪	1	
*	175	31200-KEC8-9000	0	MOTOR ASSY STARTER	起動馬達	1	
*	177	96001-06016-08	0	BOLT FLANGE SH 6*16	螺絲 6X16	2	
*	180	90701-GY6-9600	0	PIN DOWEL 6X10	定位銷 6X10	1	
*	185	11361-KEC8-9000	0	COVER LEFT REAR CRANK CASE	左後曲軸箱蓋	1	
*	186	96001-06028-08	0	BOLT FLANGE SH 6*28	螺絲 6X28	2	
*	187	11340-KEC8-9000	0	COVER COMP L CRANK CASE	左曲軸箱蓋	1	
*	188	94301-10160	0	PAN A DOWEL 10*16	定位銷 10X16	2	
*	189	91303-377-0010	0	O-RING 13.8*2.5	O環 13.8X2.5	1	
*	190	90084-KAK-9000	0	CAP AC GENERATOR	A.C.G 蓋	1	

E 6 Generator Starting Motor

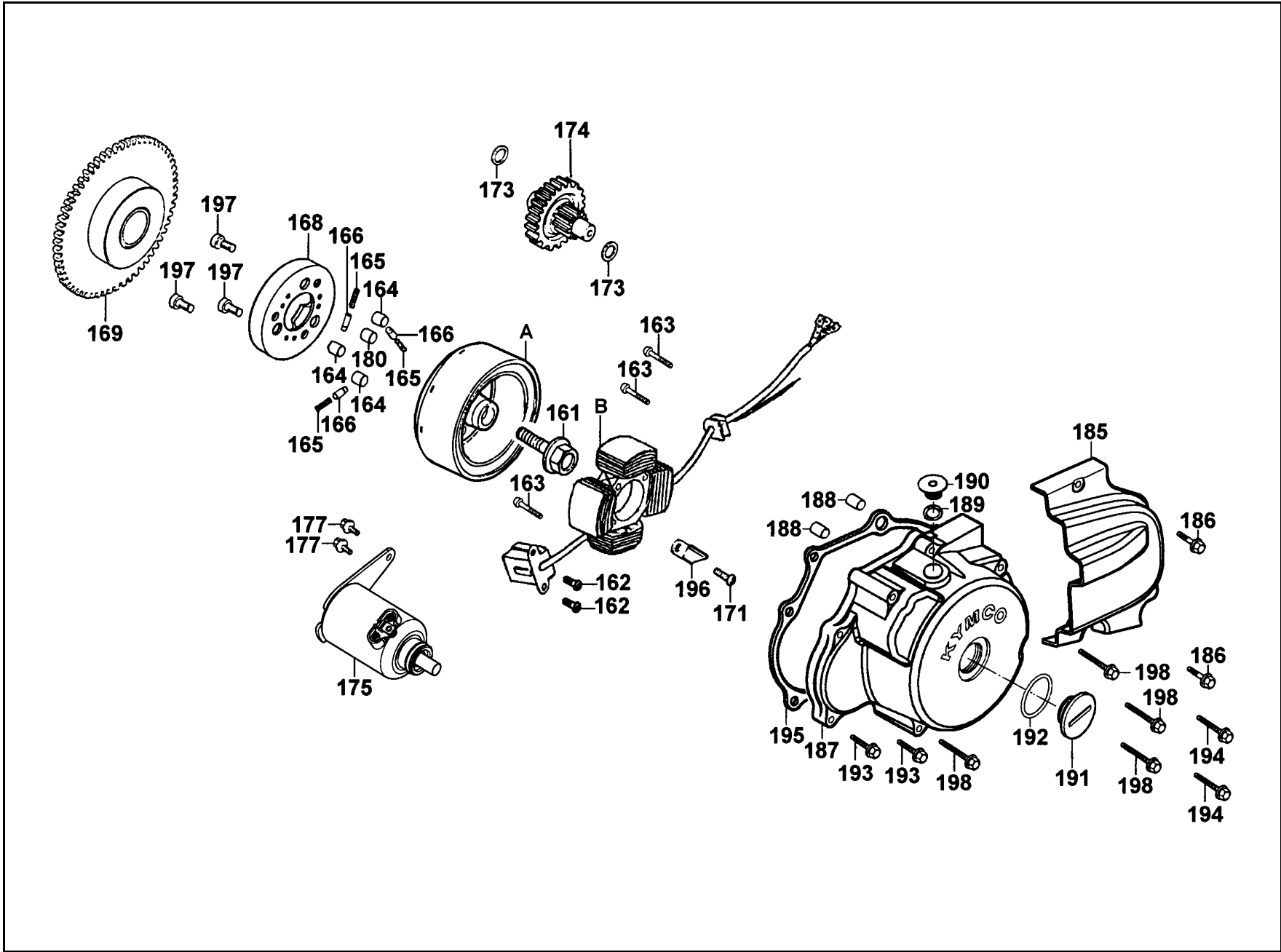

販賣記號	項目	零件號碼	版數	英文名稱	中文名稱	需要用量	參考價
Sales mark	Ref no	Part no	Ver	Description	Chinese	Regd no	Ref Price
*	191	90087-428-C000	0	CAP 30MM	蓋	1	
*	192	91302-567-0030	0	O-RING 27.4*2.4	O環 27.4X2.4	1	
*	193	96001-06028-08	0	BOLT FLANGE SH 6*28	螺絲 6X28	2	
*	194	96001-06045-08	0	BOLT FLANGE SH 6*45	螺絲 6X45	2	
*	195	11395-KEC8-9000	0	GASKET L CRANK CASE	左曲軸箱蓋墊片	1	
*	196	32976-107-0000	0	CLAMPER WIRE HARNESS	配線固定夾	1	
*	197	96600-08015-10	1	SOCKET BOLT 8*15	螺絲 8X15	3	
*	198	96001-06065-08	0	BOLT FLANGE SH 6*65	螺絲 6X65	4	
*	A	31110-KEC8-9000-M1	0	FLYWHEEL COMP	飛輪	1	
*	A	31110-KEC8-9000-M2	0	FLYWHEEL COMP	飛輪	1	
*	B	31120-KEC8-9000-M1	0	STATOR COMP	轉子線圈	1	
*	B	31120-KEC8-9000-M2	0	STATOR COMP	轉子線圈	1	

E 7 Crankcase

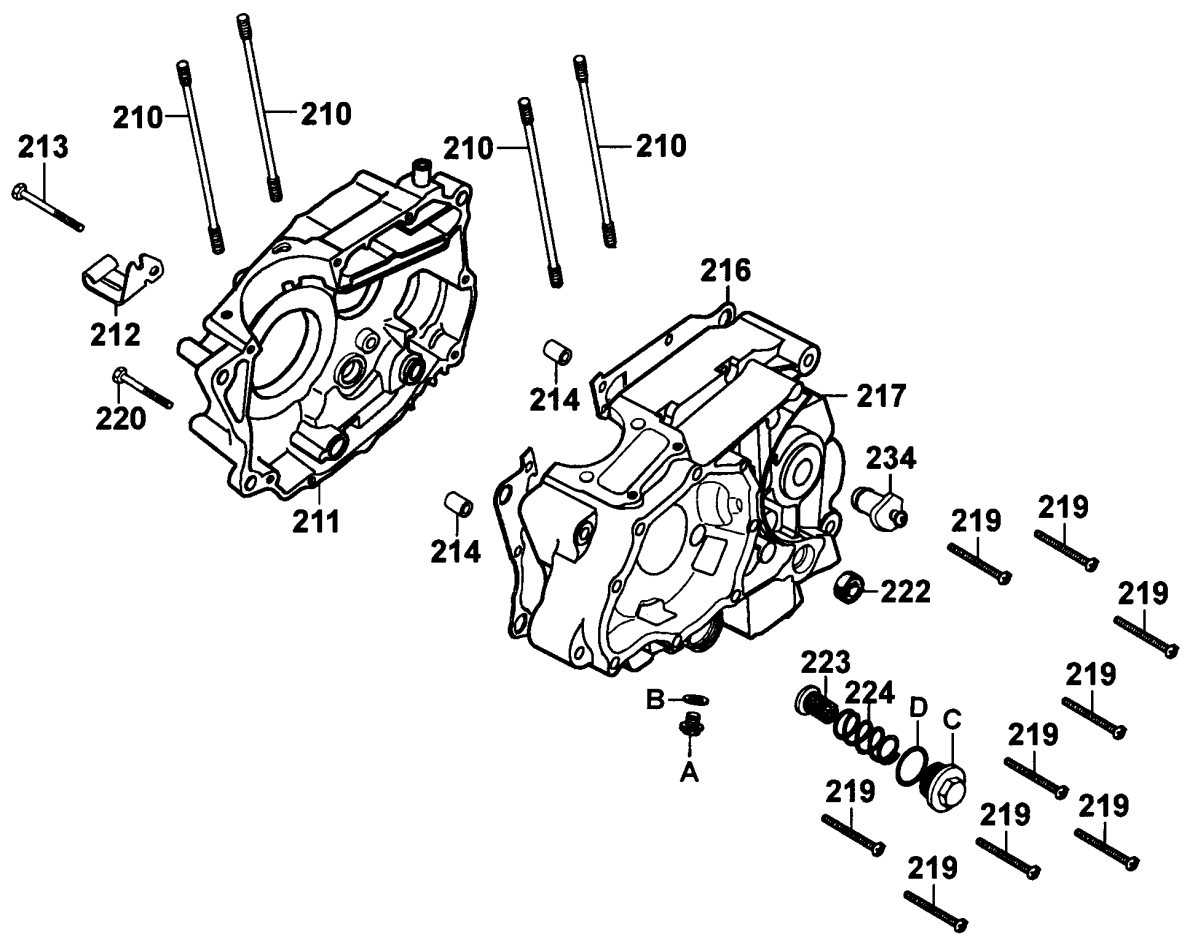

販賣記號	項目	零件號碼	版數	英文名稱	中文名稱	需要用量	參考價
Sales mark	Ref no	Part no	Ver	Description	Chinese	Regd no	Ref Price
*	210	90031-KBE-9000	0	BOLT A STUD 8MM	汽缸螺絲 8MM	4	
*	211	11100-KEC8-9000	0	CRANK CASE COMP RIGHT	右曲軸箱組	1	
*	212	22838-355-0010	0	HOLDER CLUTCH WIRE	離合器導線固定座	1	
*	213	90081-355-0010	0	BOLT HS 6*55	螺絲 6X55	1	
*	214	94301-10160	0	DOWEL PIN 10*16	定位銷 10X16	2	
*	216	11191-KEC8-9000	0	GASKET CRANK CASE	曲軸箱墊片	1	
*	217	11200-KEC8-9000	0	CRANK CASE COMP LEFT	左曲軸箱組	1	
*	219	96001-06050-O8	0	BOLT FLANGE SH 6*50	螺絲 6X50	9	
*	220	96001-06040-O8	0	BOLT FLANGE SH 6*40	螺絲 6X40	1	
*	222	91206-286-0140	0	OIL SEAL 14*28*7	油封 14X28X7	1	
*	223	15421-107-0000	1	SCREEN OIL FILTER	濾油網	1	
*	224	15426-107-0000	0	SPRING OIL FILTER SCREEN	濾油網彈簧	1	
*	234	3575A-001-0200	0	CONTACT SET NEUTRA	中立燈開關	1	
*	A	90036-GY6-9500	0	BOLT PLUG DRAIN SPECIAL	放油螺絲	1	
*	B	90521-GY6-9500	0	WASHER SPECIAL	放油螺絲華司	1	
*	C	12361-107-0010	0	HOLE CAP TAPPET ADJUSTING	調節螺帽	1	
*	D	91303-107-0000	1	O-RING 35*3.0	O環 35X3	1	

E 8 Crank Shaft●Piston

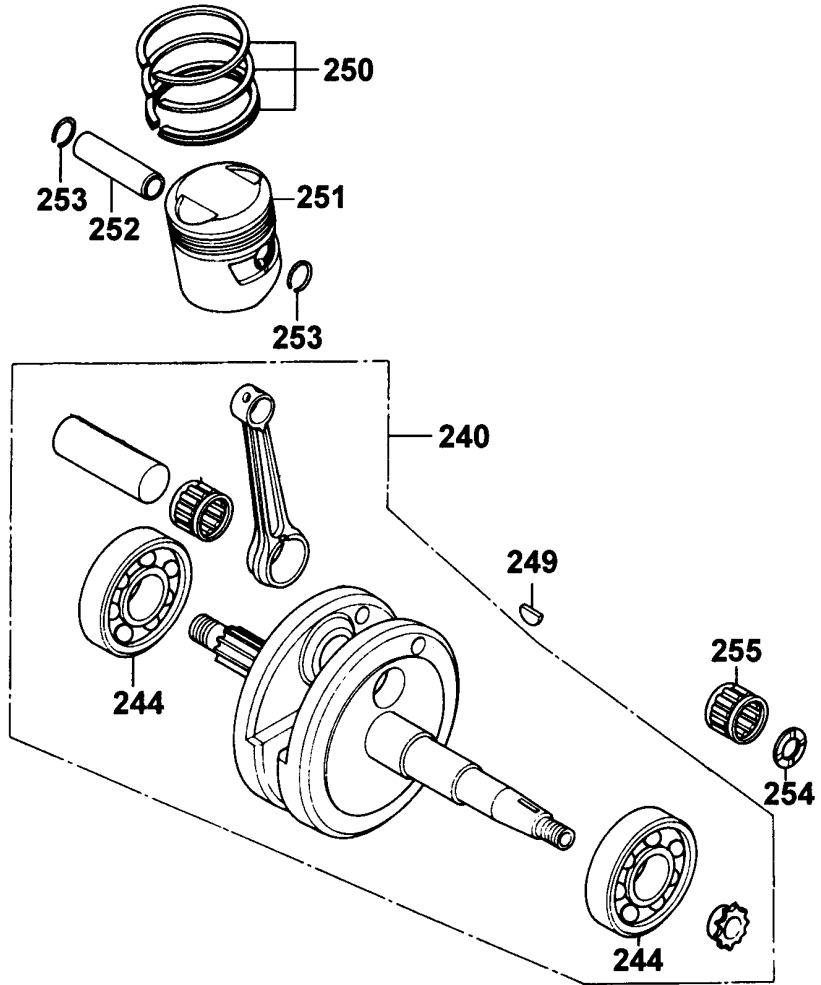

E 8

販賣記號	項目	零件號碼	版數	英文名稱	中文名稱	需要用量	參考價
Sales mark	Ref no	Part no	Ver	Description	Chinese	Regd no	Ref Price
*	240	13000-KEC8-9000	0	CRANK SHAFT COMP	曲軸	1	
*	244	91001-KEC8-9000	0	BRG BALL RAD 63/28JR2	軸承	2	
*	249	94401-25140-M1	0	WOODRUFF KET 25*14	月形固定片	1	
*	250	13011-383-6210	0	RING SET PISTON	活塞環組	1	
*	251	13101-383-0210	0	PISTON	活塞	1	
*	252	13111-440-0010	0	PIN PISTON	活塞銷	1	
*	253	94601-15000	0	CIR PISTON PIN 15MM	活塞銷夾 15MM	2	
*	254	28114-KEC8-9000	0	BOSS STARTING GEAR COMP	墊片	1	
*	255	91104-KEC8-9000-M1	0	BRG NEEDLE 22*28*17V2	軸承	1	

E 9 Transmission ● Kick Starter

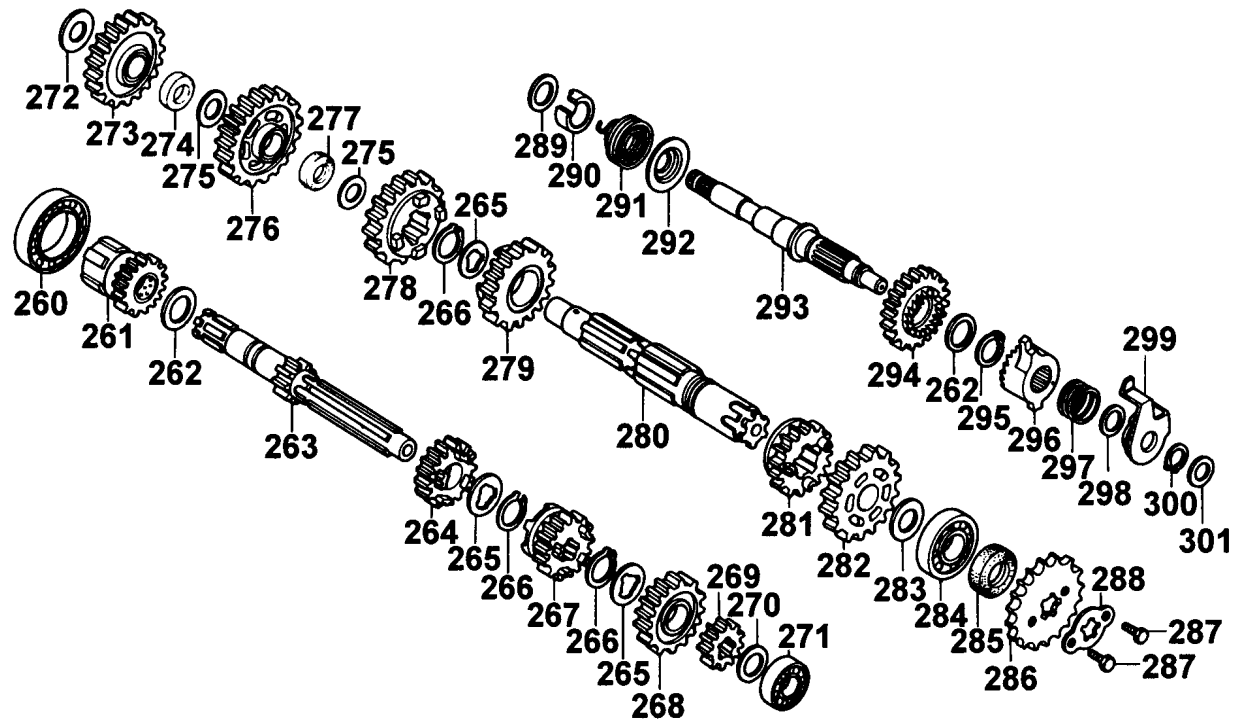

販賣記號	項目	零件號碼	版數	英文名稱	中文名稱	需要用量	參考價
Sales mark	Ref no	Part no	Ver	Description	Chinese	Regd no	Ref Price
*	260	96100-60060-00	0	BRG RADIAL BALL 6006	軸承 6006	1	
*	261	23520-383-0010	0	GEAR COMP STARTER	驅動最初齒輪	1	
*	262	90453-107-0020	0	WASHER THRUST 20M/M	華司 20MM	2	
*	263	23211-383-0010	0	SHAFT MAIN TRANSMISSION	主軸	1	
*	264	23461-439-0000	1	GEAR M-3 (20T)	主軸第三齒輪	1	
*	265	90455-107-0010	0	WASHER SPLINE 20M/M A	華司	3	
*	266	90605-200-0010	0	SET RING 20MM	固定環 20MM	3	
*	267	23481-439-0000	0	GEAR M-4 (23T)	主軸第四齒輪	1	
*	268	23501-KAK-9000	1	MAIN SHAFT FIFTH	主軸五速齒輪	1	
*	269	23441-KAK-9000	0	GEAR M-2	主軸二速齒輪	1	
*	270	90451-107-0000	1	WASHER THRUST 15M/M	華司	1	
*	271	96120-62020-00	0	BRG RADIAL BALL	軸承	1	
*	272	90451-365-0010	0	WASHER THRUST 15M/M	華司	1	
*	273	23531-439-0000	1	GEAR ONLY IDLE STARTER	驅動最初惰齒輪	1	
*	274	23431-439-0000	0	COLLAR IDLE STARTER GEAR	起動惰齒輪軸環	1	
*	275	90452-107-0010	0	WASHER THRUST 16.5M/M	華司 16.5MM	2	
*	276	23426-KAK-9000	0	GEAR COUNTER SHAFT LOW	副軸低速齒輪	1	
*	277	23427-439-0000	0	COLLAR COUNTER SHAFT LOW GEAR	對軸低速齒輪軸環	1	
*	278	23471-439-0000	0	GEAR C-3 (28T)	副軸第三齒輪	1	
*	279	23491-439-0000	1	GEAR C-4 (26T)	副軸第四齒輪	1	

E 9 Transmission ● Kick Starter

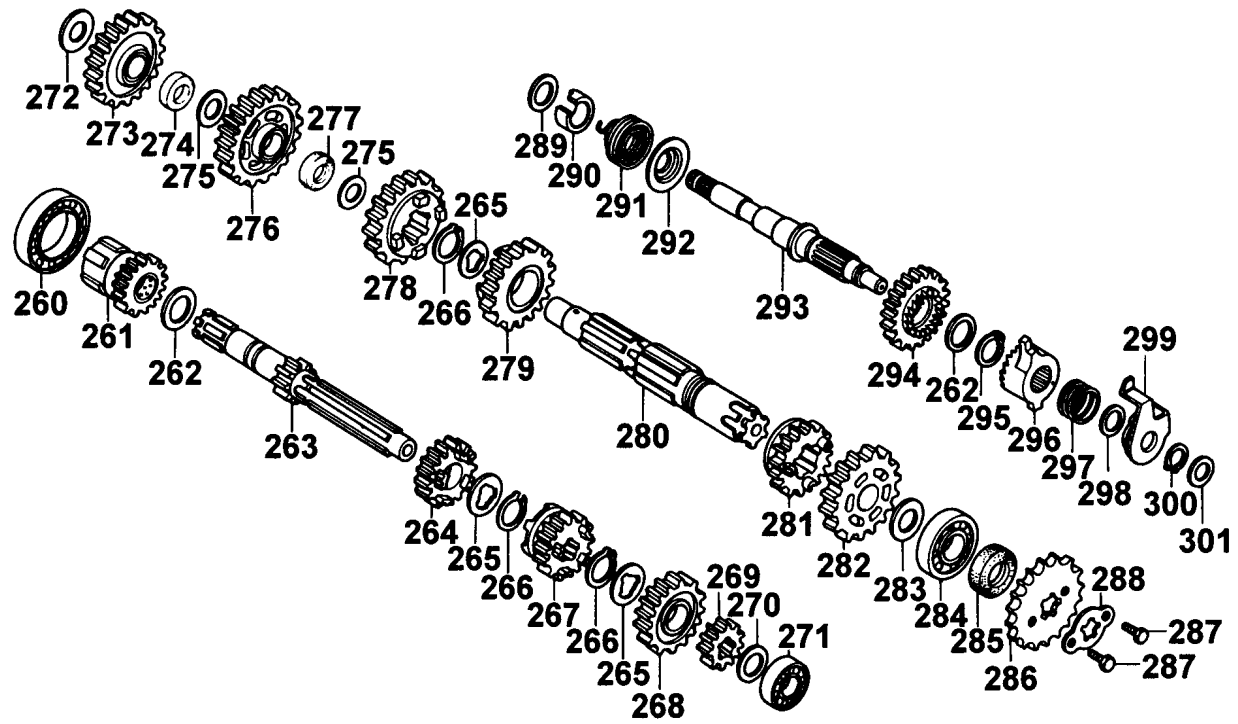

販賣記號	項目	零件號碼	版數	英文名稱	中文名稱	需要用量	參考價
Sales mark	Ref no	Part no	Ver	Description	Chinese	Regd no	Ref Price
*	280	23221-KAK-9000	0	SHAFT COUNTER TRANSMISSION	傳動副軸	1	
*	281	23511-KAK-9000	1	GEAR C-5	副軸五速齒輪	1	
*	282	23451-KAK-9000	0	GEAR C2	副軸二速齒輪	1	
*	283	90454-107-0010	0	WASHER THRUST 20MM B	華司 20MM	1	
*	284	96100-62040-00	0	BEARING BALL 6204	軸承 6204	1	
*	285	91201-030-0260	1	OIL SEAL S 20*34*7	油封 20X34X7	1	
*	286	23801-KAK-9000	0	SPROCKET DRIVE	驅動齒輪	1	
*	287	92000-06010-0H	0	BOLT HEX 6*10	螺絲 6X10	2	
*	288	23811-KR3-6000	0	PLATE A2 FIXING	固定板 A2	1	
*	289	90462-107-0010	0	WASHER THRUST 16M/M	華司 16MM	1	
*	290	28262-397-0000	0	COLLAR KICK SPINDLE	起動臂軸套筒	1	
*	291	28261-397-0000	2	SPRING KICK STARTER	起動彈簧	1	
*	292	28263-397-0000	0	RETAINER STARTER SPRING	起動彈簧承座	1	
*	293	28251-397-0110	0	SPINDLE KICK STARTER	起動臂軸	1	
*	294	28211-397-0100-M1	1	PINION KICK STARTER	起動小齒輪	1	
*	295	94510-20000	0	CIR CLIP EXTERNAL 20	外環夾 20MM	1	
*	296	28221-397-0200-M1	1	RATCHET KICK STARTER	起動小齒輪掣子	1	
*	297	28253-KA2-0000	0	SPRING KICK STARTER RATCHET	起動臂彈簧	1	
*	298	90453-235-0010	0	WASHER THRUST 16MM	華司 16MM	1	
*	299	28270-397-0210	0	PLATE COMP RATCHET GUIDE	掣子導片	1	

E 9 Transmission ● Kick Starter

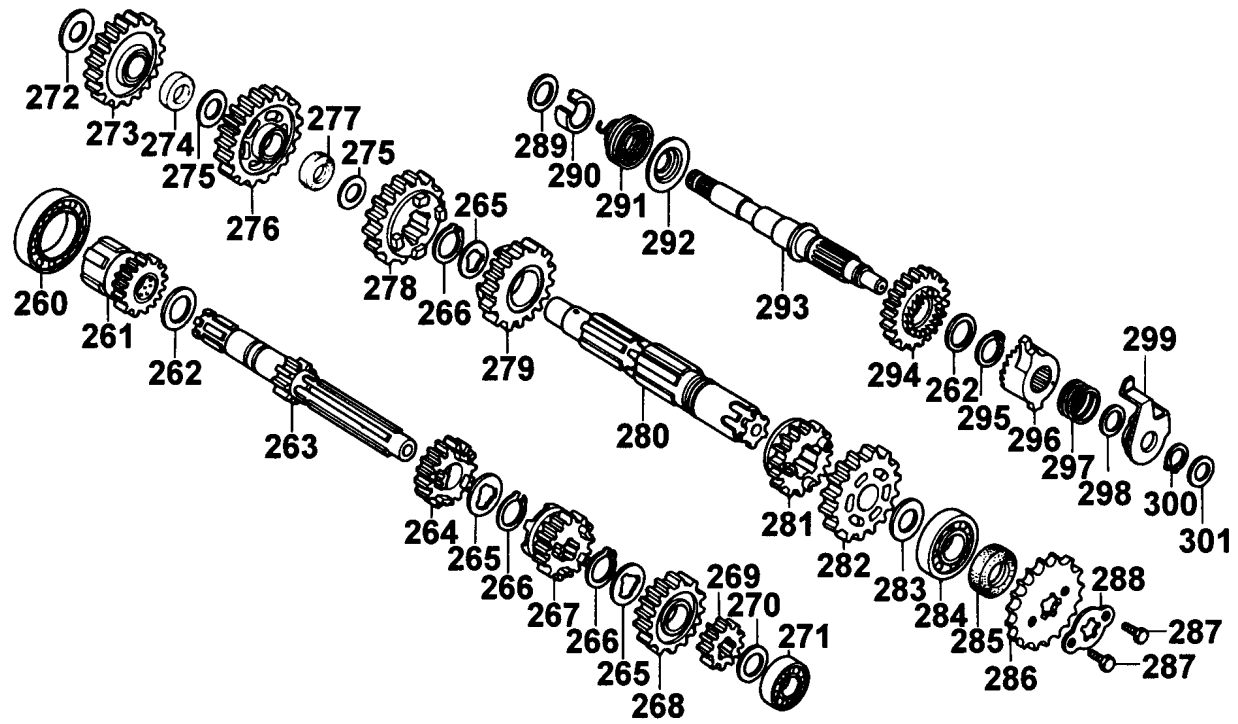

販賣記號	項目	零件號碼	版數	英文名稱	中文名稱	需要用量	參考價
Sales mark	Ref no	Part no	Ver	Description	Chinese	Regd no	Ref Price
*	300	94510-16000	0	CIR CLIP EXTERNAL	外環夾	1	
*	301	90459-107-0000	0	WASHER THRUST 12M/M	華司 12MM	1	

販賣記號	項目	零件號碼	版數	英文名稱	中文名稱	需要用量	參考價
Sales mark	Ref no	Part no	Ver	Description	Chinese	Regd no	Ref Price
*	311	24610-KC6-0000	2	SPINDLE COMP GEAR SHIFT	齒輪變換樞軸	1	
*	312	24621-107-7600	4	PLATE GEAR SHIFT	齒輪軸板	1	
*	313	24631-107-0000	0	SPRING GEAR SHIFT PLATE	齒輪軸彈簧	1	
*	314	94510-12000	0	CIR CLIP EXTERNAL 12	外環夾 12MM	1	
*	315	24651-398-9400	0	SPRING GEAR SHIFT RETURN	齒輪變換回轉彈簧	1	
*	316	90451-001-0000	2	WASHER THRUST 14M/M	華司 14MM	1	
*	317	94510-14000	0	CIR CLIP EXTERNAL 14	外環夾 14MM	1	
*	318	24241-107-0000	1	SHAFT GEAR SHIFT FORK GUIDE	變換叉樞軸	1	
*	319	24211-107-0010	0	FORK RIGHT GEAR SHIFT	齒輪變換右叉	1	
*	320	24231-107-0100	3	FORK CENTER GEAR SHIFT	齒輪變換中叉	1	
*	321	24221-355-0010	2	FORK LEFT GEAR SHIFT	齒輪變換左叉	1	
*	322	24301-KAK-9000	2	DRUM GEAR SHIFT	齒輪變速鼓輪	1	
*	323	92000-06025-0H	0	BOLT HEX 6*25	螺絲 6X25	1	
*	324	24411-KAK-9000	0	CAM GEAR SHIFT	齒輪變速凸輪	1	
*	325	96220-40100-M1	0	ROLLAR 4*10	滾銷 4X10	1	
*	326	35753-028-6010	0	ROTOR NEUTROL SWITCH	中立開關銅片	1	
*	327	24430-324-0000	2	STOPPER COMP GEAR SHIFT DRUM	齒輪軸板	1	
*	328	92000-06020-0H	0	BOLT HEX 6*20	螺絲 6X20	1	
*	329	24435-KAK-9000	0	SPG SHIFT DRUM STOPPER	軸板彈簧	1	
*	330	90451-001-0000	2	WASHER THRUST 14M/M	華司 14MM	1	

E 10

E 11 Carburetor

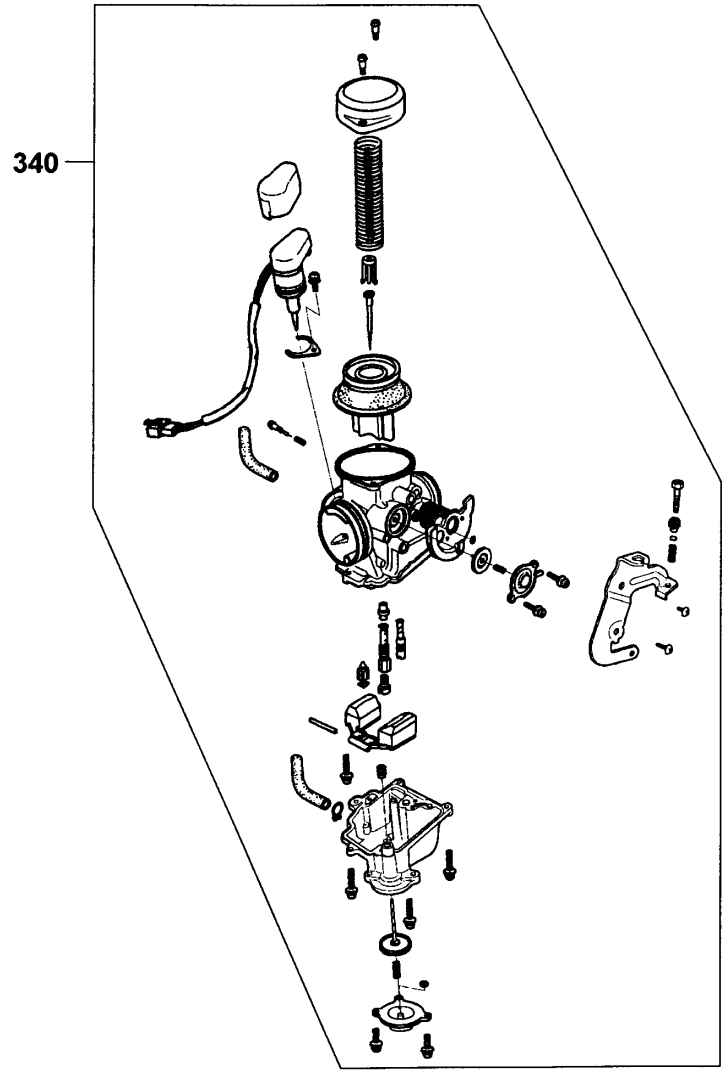

販賣記號	項目	零件號碼	版數	英文名稱	中文名稱	需要用量	參考價
Sales mark	Ref no	Part no	Ver	Description	Chinese	Regd no	Ref Price
*	340	1610K-KEC8-E000	0	CARBURETOR ASSY	化油器組	1	

E 11

F 1 Cable Switch handle lever

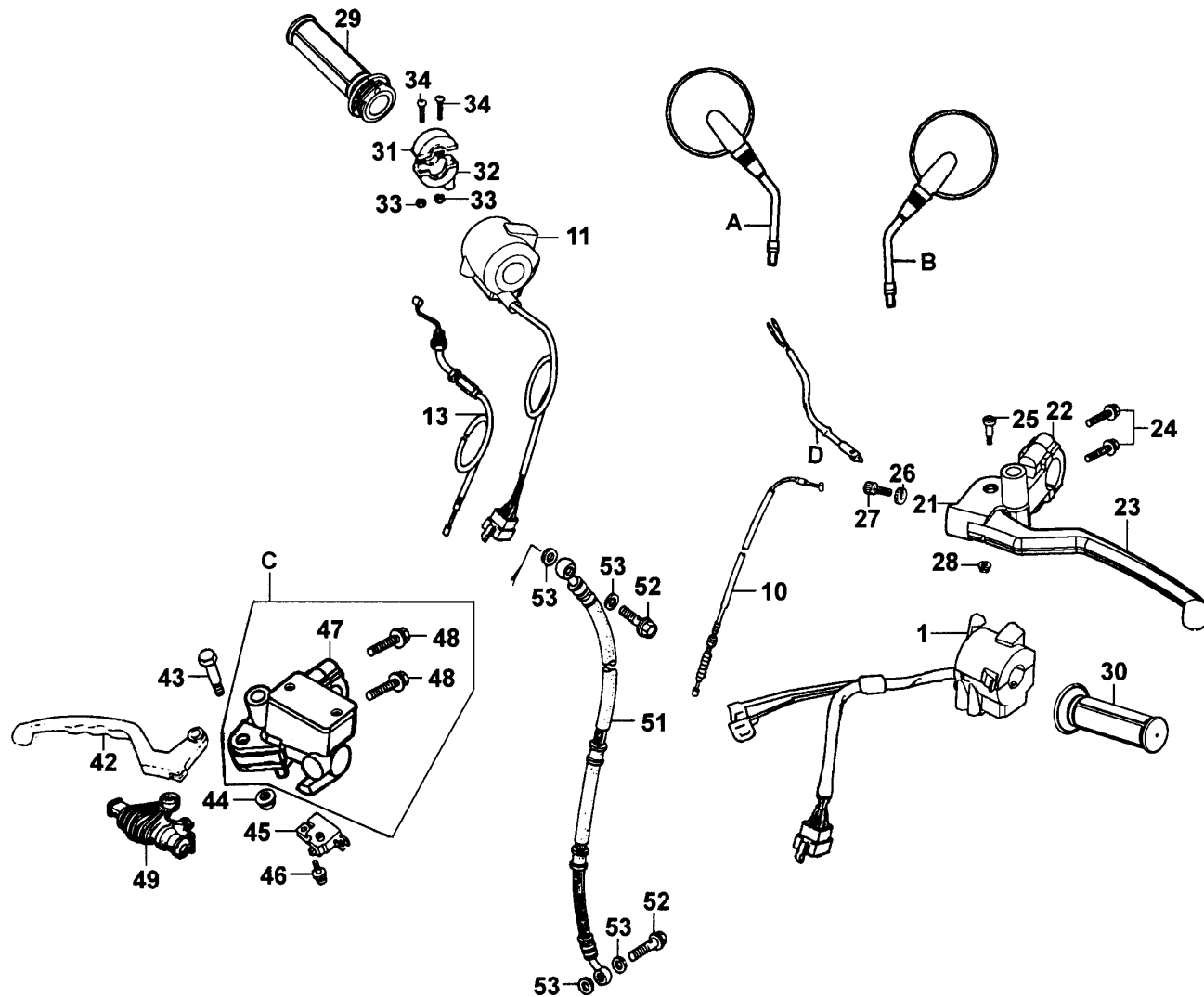

販賣記號	項目	零件號碼	版數	英文名稱	中文名稱	需要用量	參考價
Sales mark	Ref no	Part no	Ver	Description	Chinese	Regd no	Ref Price
*	1	3520A-KEC8-9000	0	SW ASSY LH HANDLE COMP	轉向手柄左開關組	1	
*	10	22870-KE2-9810	0	CABLE COMP CLUTCH	離合器導線	1	
*	11	3515A-KEC8-9000	0	SW ASSY RH HANDLE COMP	轉向手柄右開關組	1	
*	13	17910-KEC8-9000	1	CABLE COMP THROT	節流導線	1	
*	21	53172-KEC8-9000	0	BRKT HANDLE L	手柄左托架	1	
*	22	53173-KAK-9000	0	BRKT HANDLE BAND	手柄左托架固定板	1	
*	23	53178-KEC8-9000	0	LEVER L STRG HNDL	左拉桿	1	
*	24	96001-06020-02	0	FLANGE BOLT 6*20	螺絲 6X20	2	
*	25	90113-422-0000	2	BOLT L STRG HNDL LEVER PIVOT	手拉桿軸螺絲	1	
*	26	90321-315-6710	0	NUT FIXING	螺帽	1	
*	27	53192-268-0000	5	BOLT WIRE ADJUST	離合器導線調整螺絲	1	
*	28	94050-06080	0	NUT FLANGE 6MM	螺帽 6MM	1	
*	29	53140-KEC8-9000	0	GRIP COMP TUROT	手柄右橡皮套組	1	
*	30	53166-KEC8-9000	0	GRIP COMP L HANDLE	手柄左橡皮套組	1	
*	31	53168-KW6-9010	0	HOUSING UP THROT	節流管上固定座	1	
*	32	53167-KW6-9010	0	HOUSING UND THROT	節流管下固定座	1	
*	33	94001-05070-0S	0	NUT HEX 5MM	螺帽 5MM	2	
*	34	93500-05025-OH	0	SCREW PAN 5*25	螺絲 5X25	2	
*	42	53175-KAK-9000	2	LEVER R STRG HNDL	右拉桿	1	
*	43	90113-KEC8-8000	0	BOLT HANDLE LEVER	右拉桿固定螺栓	1	

F 1 Cable Switch handle lever

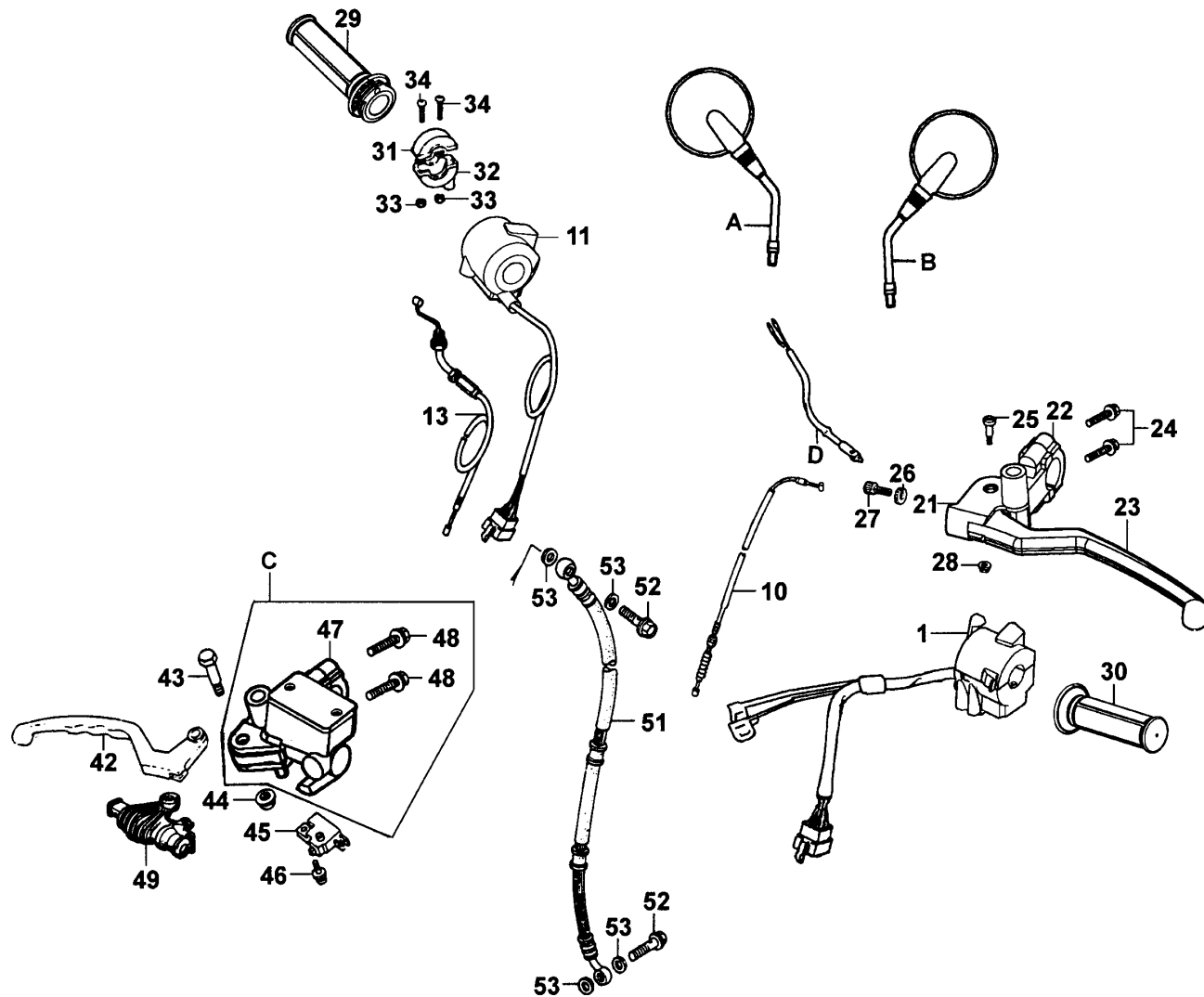

F 1

販賣記號	項目	零件號碼	版數	英文名稱	中文名稱	需要用量	參考價
Sales mark	Ref no	Part no	Ver	Description	Chinese	Regd no	Ref Price
*	44	94050-06020-02	0	NUT FLANGE 6MM	螺帽 6MM	1	
*	45	35340-KBN-9000	0	SW ASSY FR STOP	剎車燈前置開關組	1	
*	46	93893-04012-18	0	SCREW WASHER 4*12	螺絲 4X12	1	
*	47	45517-KAK-9000	0	HOLDER M/C	主油缸固定座	1	
*	48	96001-06020-02	0	BOLT FLANGE SH 6*20	螺絲 6X20	2	
*	49	53173-KG7-9010	0	COVER R HNDL LEVER	右拉桿護蓋	1	
*	51	45126-KEC8-9000	0	HOSE ASSY FR BRK	前煞車油管	1	
*	52	90145-MS9-6120-M1	0	OIL BOLT 10*22	油管螺絲 10X22	2	
*	53	90545-300-0000	0	WASHER OIL BOLT	華司	4	
*	A	88110-KEC8-E000	0	MIRROR ASSY R BACK	右後視鏡	1	
*	B	88120-KEC8-E000	0	MIRROR ASSY R BACK	左後視鏡	1	
*	C	45530-KAK-3060	0	CYLINDER SET FR MASTER	煞車油主缸組	1	
*	D	35340-GY6-9100	0	SW ASSY FR STOP	煞車燈前置開關	1	

F 2 Head light

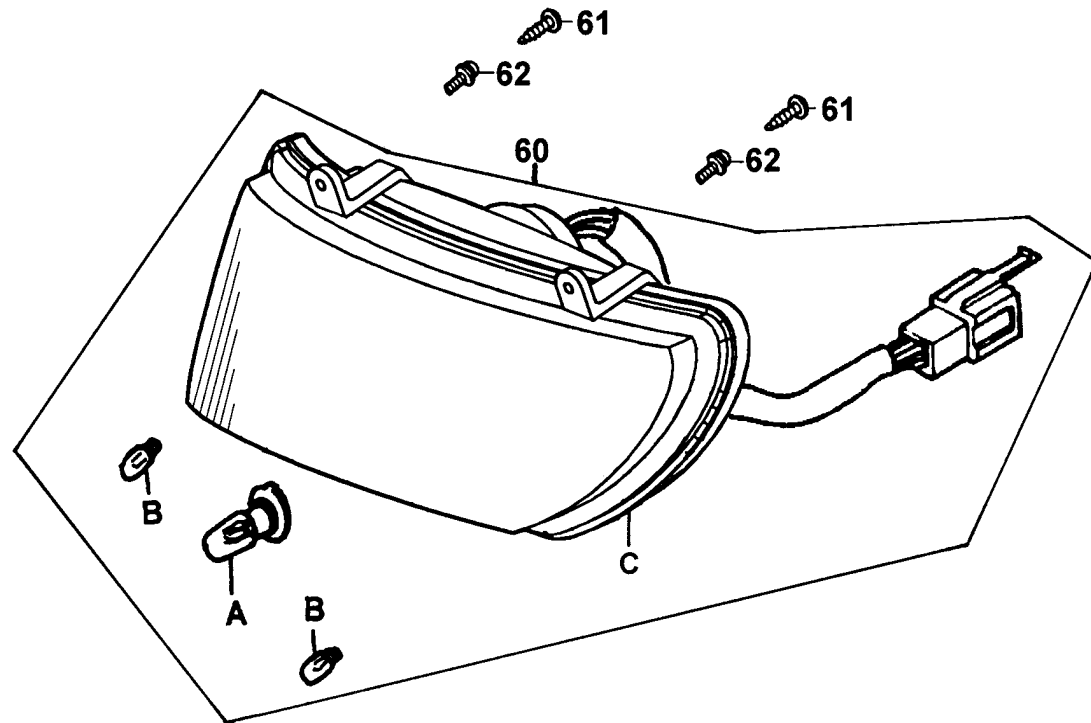

販賣記號	項目	零件號碼	版數	英文名稱	中文名稱	需要用量	參考價
Sales mark	Ref no	Part no	Ver	Description	Chinese	Regd no	Ref Price
*	60	33100-KEC8-9000	0	LIGHT ASSY HEAD	前燈組	1	
*	61	93893-25280	0	SCREW TAPPING 5*12	螺釘 5X12	2	
*	62	93891-05012-07	0	SCREW WASHER 5*12	螺絲 5X12	2	
*	A	34901-KAB-9000	0	BULB HEAD LIGHT	前燈燈泡	1	
*	B	34908-KCU-9000	0	BULB POSITION LIGHT	燈泡	2	
*	C	33120-KEC8-9000	0	UNIT HEAD LIGHT	前燈殼	1	

F 3 Speedometer

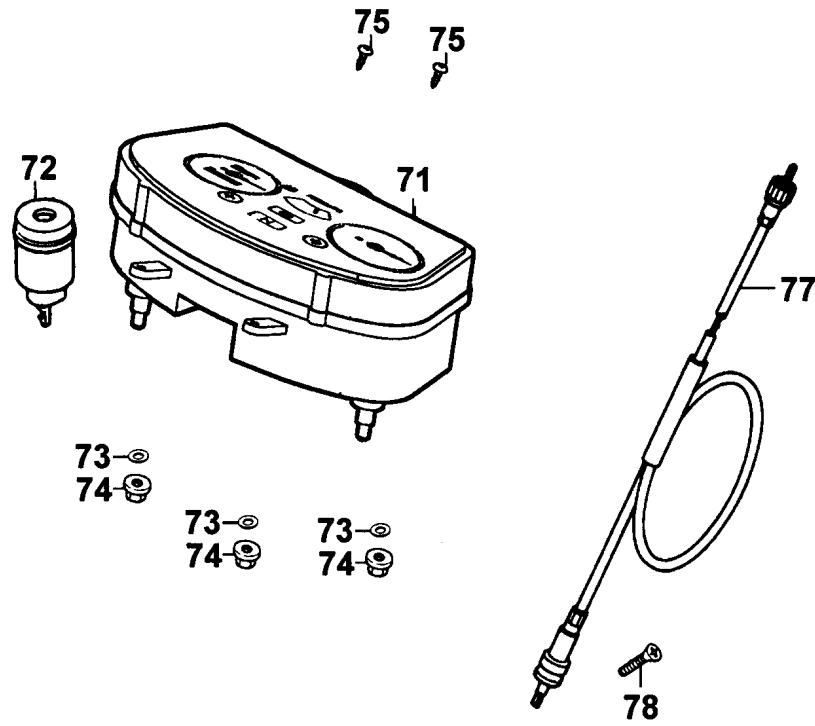

F 3

販賣記號	項目	零件號碼	版數	英文名稱	中文名稱	需要用量	參考價
Sales mark	Ref no	Part no	Ver	Description	Chinese	Regd no	Ref Price
*	71	37200-KEC8-9000	0	METER ASSY SPEED	速度錶組	1	
*	72	38301-GW0-9010	0	RELAY COMP AP WINLER	方向燈繼電器	1	
*	73	94103-06700	0	WASHER PLAIN 6MM	螺釘 6MM	3	
*	74	94050-06080	0	NUT FLANGE 6MM	螺帽 6MM	3	
*	75	93903-34480	0	SCREW TAPPING 4*16	螺釘 4X16	2	
*	77	44830-KEC8-9000	0	CABLE ASSY SPEEDOMETER	速度錶導線	1	
*	78	93700-05016-0A	0	SCREW OVAL 5*16	螺絲	1	

F 4 Handle Steering●Stem

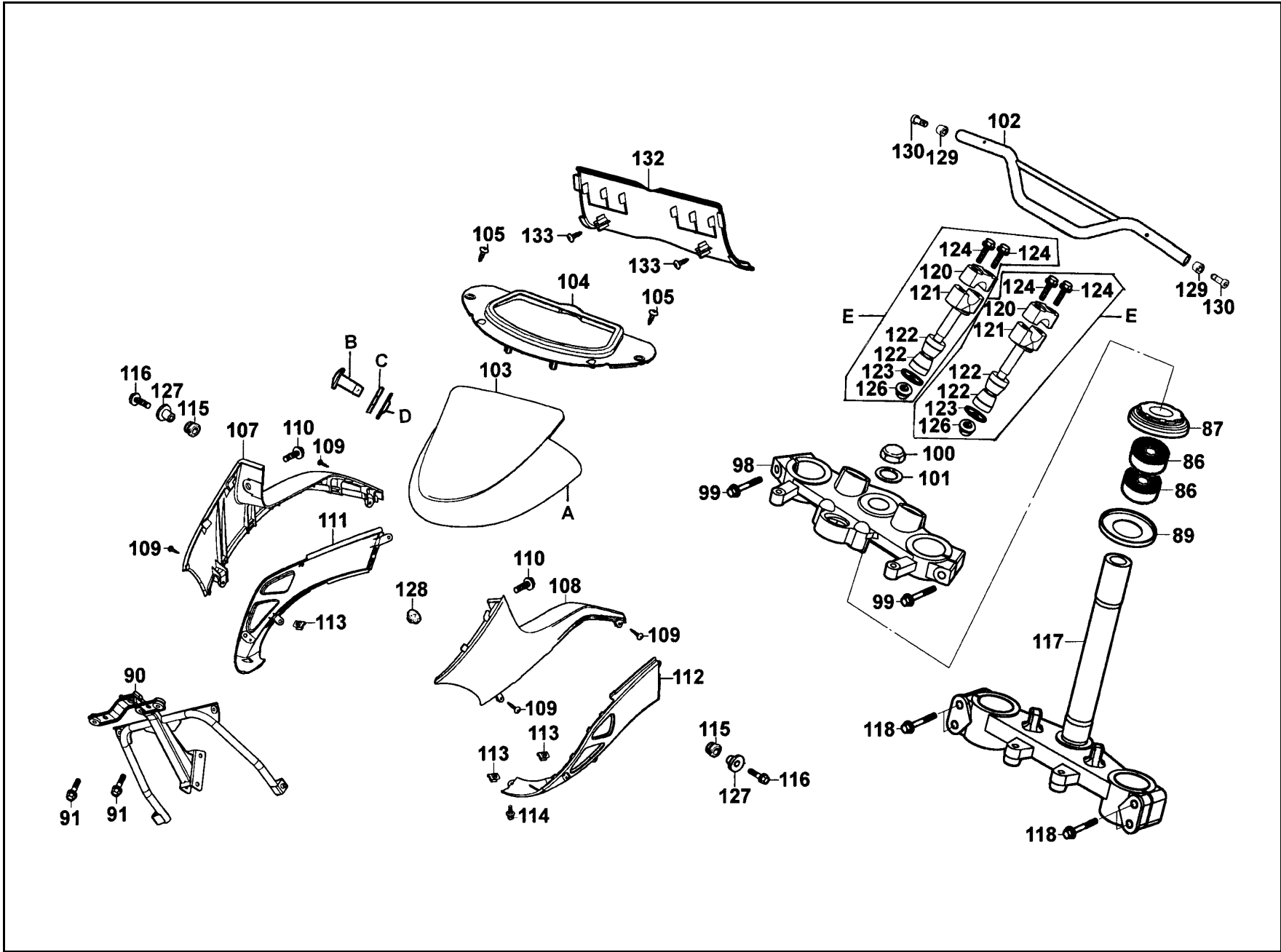

販賣記號	項目	零件號碼	版數	英文名稱	中文名稱	需要用量	參考價
Sales mark	Ref no	Part no	Ver	Description	Chinese	Regd no	Ref Price
*	86	53240-KEC8-9000	0	BEARING TAPER ROLLER ET-32005X	套筒	2	
*	87	5322A-KEC8-9000	0	THREAD COMP STRG HD TOP	轉向桿頂螺帽	1	
*	89	53214-KEC8-9000-M1	0	DUST SEAL STEM BOT	墊片	2	
*	90	6422A-KEC8-9000	0	STAY ASSY FR COWL	前擋泥板支架	1	
*	91	95801-08045-07	0	BOLT FLANGE 8*45	螺絲 8X45	2	
*	98	53230-KEC8-9000	0	BRIDGE FORK TOP	前避震器頂樑	1	
*	99	95801-08040-00	0	BOLT FLANGE 8*40	螺絲 8X40	2	
*	100	90304-KAK-9000	1	NUT STRG STEM	螺帽	1	
*	101	90503-051-8700	0	WASHER STEERING STEM NUT	鎖華司	1	
*	102	53100-KEC8-9000	0	HANDLE COMP STRG	轉向手柄	1	
*	103	64110-KEC8-9000	0	WINDSCREEN	遮陽板	1	
*	104	53204-KEC8-9000	0	COVER METER	碼錶蓋	1	
*	105	93903-35380	0	SCREW TAPPING 5*16	螺釘 5X16	2	
**	107	64302-KEC8-9000	0	COVER R FR	右前蓋	1	
**	108	64303-KEC8-9000	0	COVER L FR	左前蓋	1	
*	109	93903-34380	0	SCREW TAPPING 4*12	螺釘 4X12	4	
*	110	90110-KEB7-9000	0	SCREW SPECIAL 6*14	螺絲 6X14	2	
**	111	64304-KEC8-9000	0	COVER R SIDE	右邊蓋	1	
**	112	64305-KEC8-9000	0	COVER L SIDE	左邊蓋	1	
*	113	90677-GR1-0030	1	NUT CLIP 5MM	螺帽夾 5MM	3	

F 4 Handle Steering●Stem

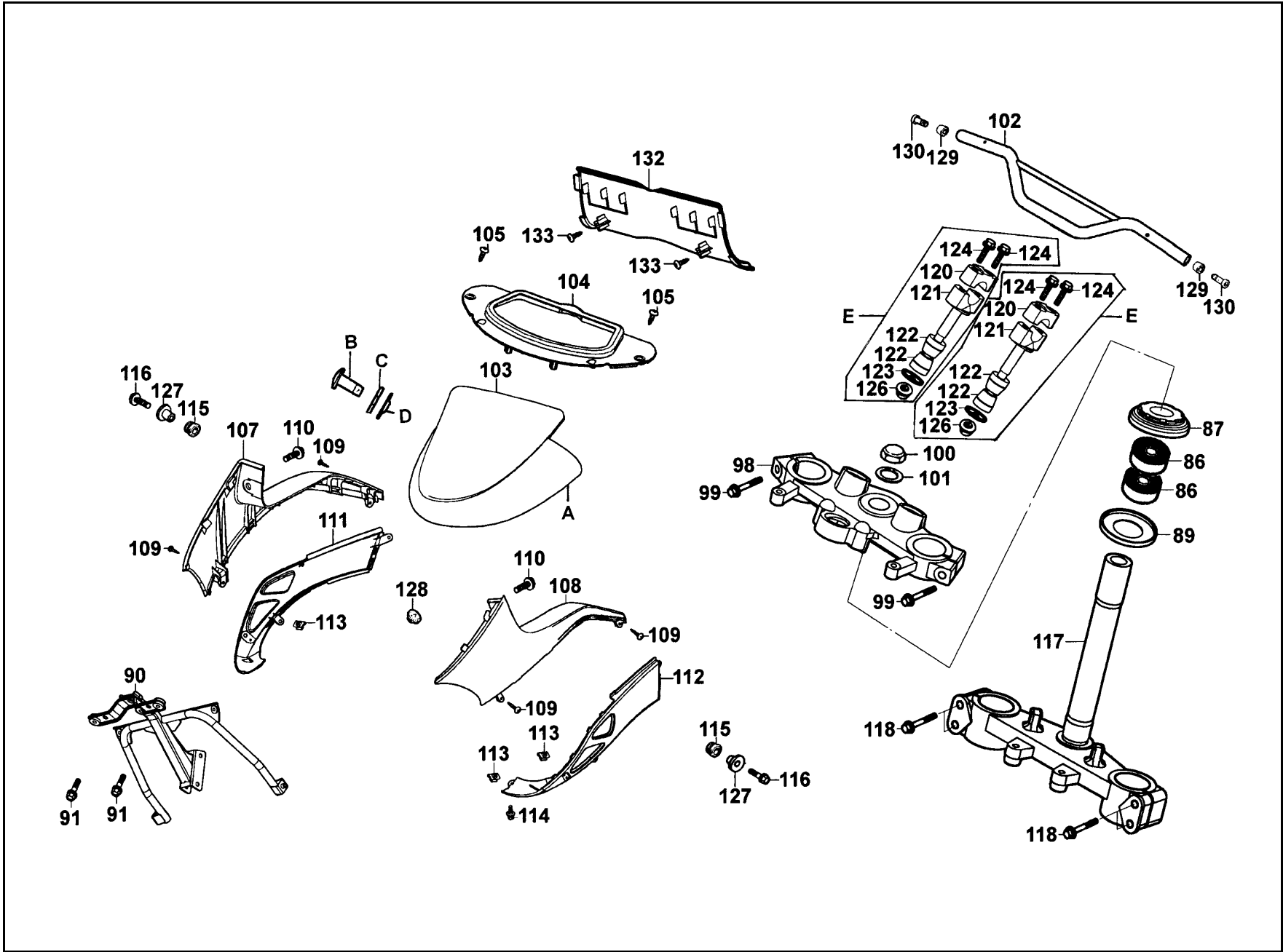

販賣記號	項目	零件號碼	版數	英文名稱	中文名稱	需要用量	參考價
Sales mark	Ref no	Part no	Ver	Description	Chinese	Regd no	Ref Price
*	114	90302-KEC8-9000	0	BOLT PAN 5*9	螺絲	1	
*	115	83551-KEC8-9000	0	GROMMET COVER	橡皮	1	
*	116	95701-06020-08	0	BOLT FLANGE 6*20	螺絲 6X20	2	
*	117	53200-KEC8-9000	0	STEM COMP STEERING	轉向桿	1	
*	118	95801-08040-02	0	BOLT FLANGE 8*40	螺絲 8X40	2	
*	120	53131-439-0000	0	HOLDER HNDL PIPE	手柄上固定座	2	
*	121	53132-439-0000	0	HOLDER UNDER HNDL PIPE	手柄下固定座	2	
*	122	53133-236-0000	0	RUBBER HANDLE CUSHION	橡皮	4	
*	123	53134-283-0010	0	HANDLE CUSHION WASHER	華司	2	
*	124	95801-08035-08	0	BOLT FLANGE 8*35	螺絲 8X35	4	
*	126	94001-10080-0S	0	NUT HEX 10MM	螺帽 10MM	2	
*	127	83550-KEC8-9000	0	COLLAR	套筒	2	
*	128	64303-KAQ-9000	0	CAP FR MOLDING	蓋子	1	
*	129	53102-KEC8-9000	0	END HANDLE	平衡端子	2	
*	130	90106-KFC2-9000	0	BOLT WASH 8MM	螺絲 8MM	2	
*	132	53205-KEC8-9000	0	DHROUD METER	碼錶導板	1	
*	133	93903-34380	0	SCREW TAPPING 4*12	螺釘 4X12	2	
**	A	64301-KEC8-9000	0	COVER UPPER FR	前上蓋	1	
*	B	64206-KBN-9000	0	PIN SCREEN SET	銷	6	
*	C	90321-KN7-9110	0	WASHER EMBLEM	華司	6	

F 4 Handle Steering●Stem

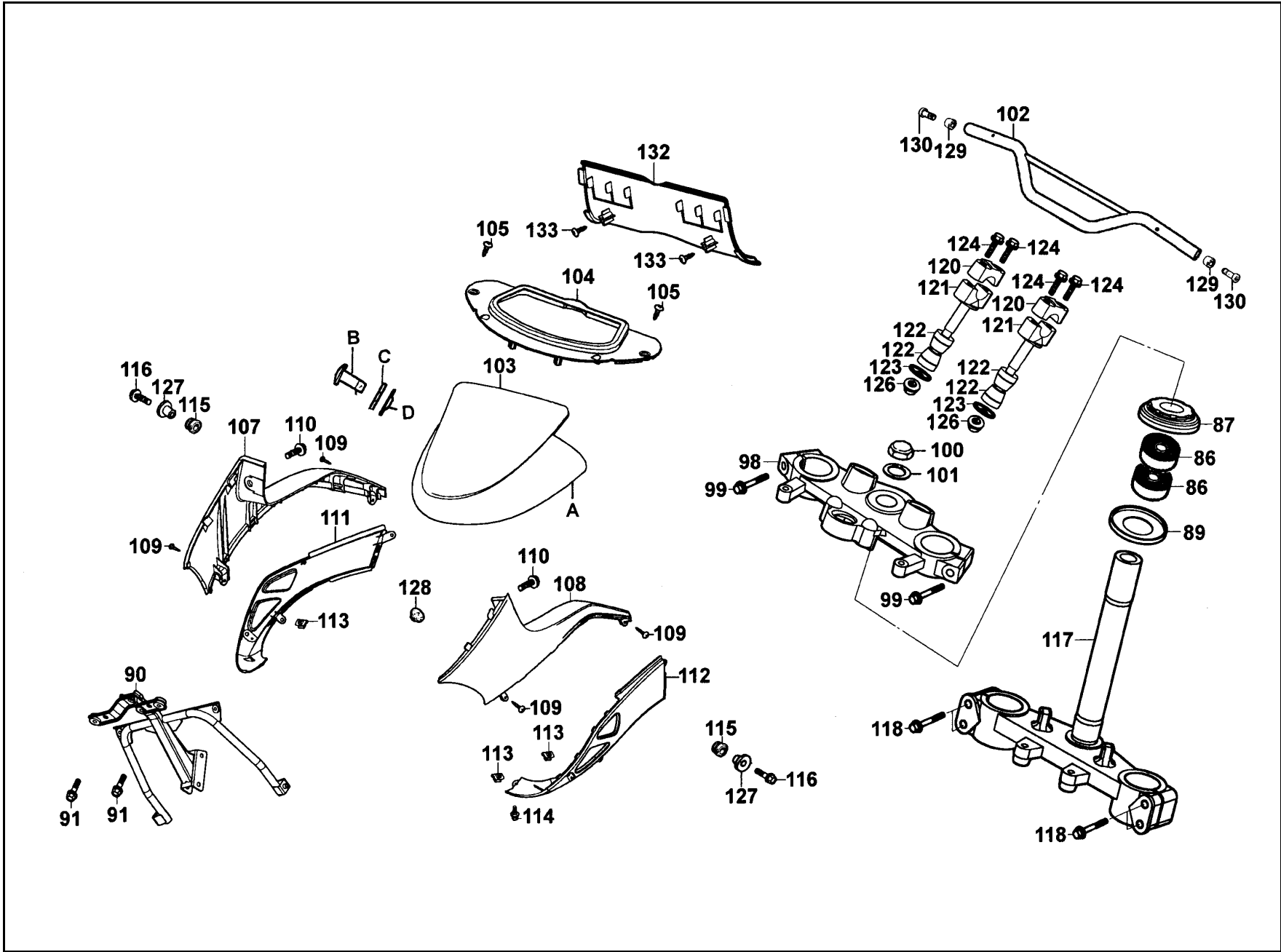

販賣記號	項目	零件號碼	版數	英文名稱	中文名稱	需要用量	參考價
Sales mark	Ref no	Part no	Ver	Description	Chinese	Regd no	Ref Price
*	D	64206-MJ0-0010	0	NUT SPEED 4MM	鐵片螺帽	6	
*	E	5313A-KEC8-9000	0	HOLDER SET HNDL	轉向手柄固定座組	1	

F 4

F 5 Front Fender

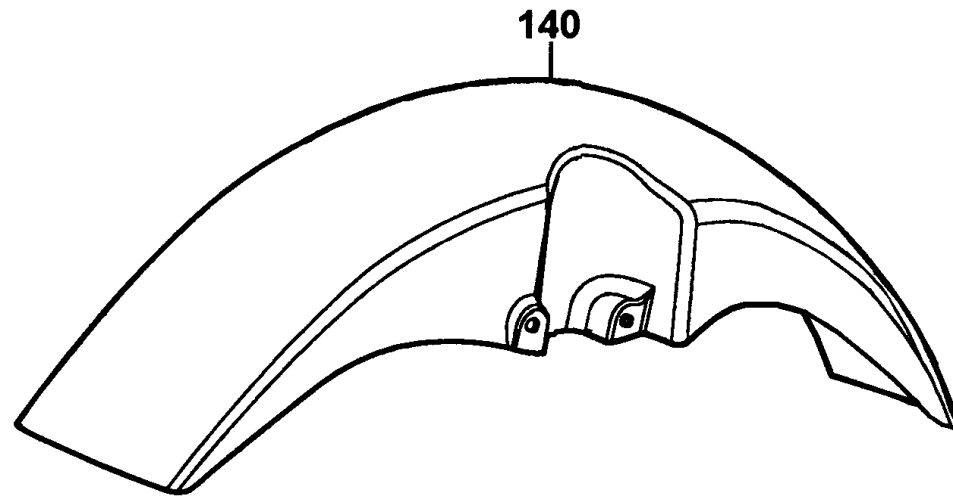

販賣記號	項目	零件號碼	版數	英文名稱	中文名稱	需要用量	參考價
Sales mark	Ref no	Part no	Ver	Description	Chinese	Regd no	Ref Price
**	140	61110-KEC8-9000	0	FENDER FR	前土除	1	

F 5

F 6 Front Fork

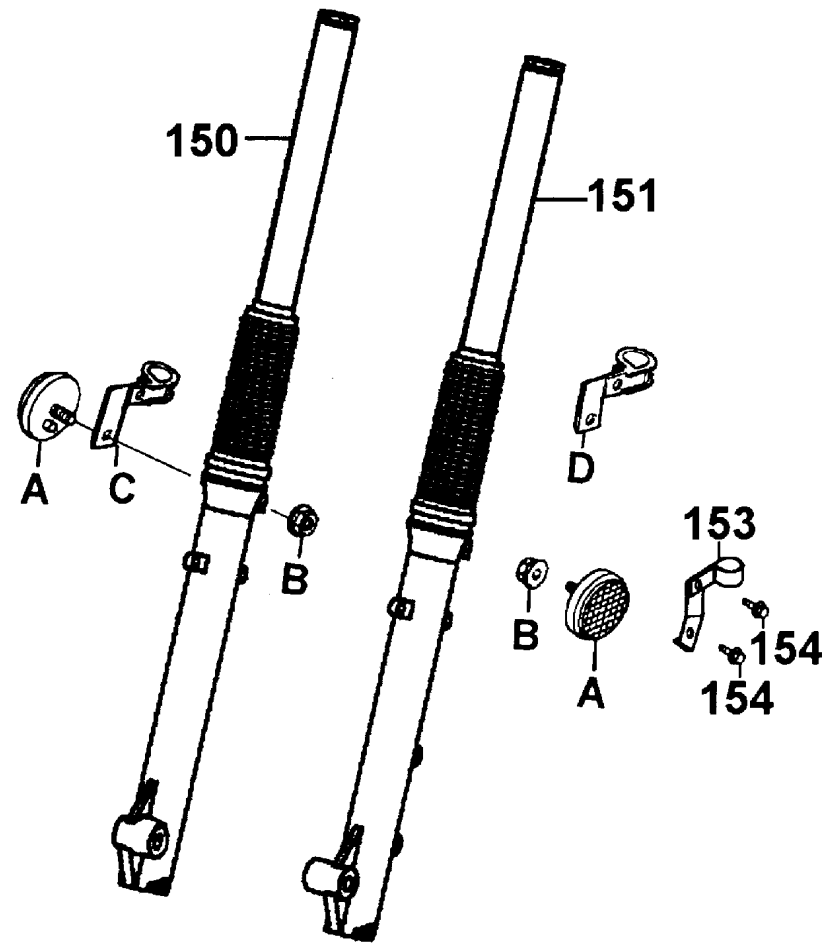

F 6

販賣記號	項目	零件號碼	版數	英文名稱	中文名稱	需要用量	參考價
Sales mark	Ref no	Part no	Ver	Description	Chinese	Regd no	Ref Price
*	150	51400-KEC8-9000	0	FORK ASSY R FRONT	右前避震器	1	
*	151	51500-KEC8-9000	0	FORK ASSY L FRONT	左前避震器	1	
*	153	45156-KBN-9000	0	CLAMPER FR BRAKE HOSE	管夾	1	
*	154	95701-06014-08	0	BOLT FLANGE 6X14	螺絲 6X14	2	
*	A	33741-GY6-C300	1	REFLEX REFLECTOR	反光片	2	
*	B	90301-634-6700	0	NUT FLANGE 6MM	螺帽	2	
*	C	90667-KEC8-9000	0	RSTAY SIDE REFLECTOR R	右反光片座	1	
*	D	90668-KEC8-9000	0	RSTAY SIDE REFLECTOR L	左反光片座	1	

F 7 Front Caliper

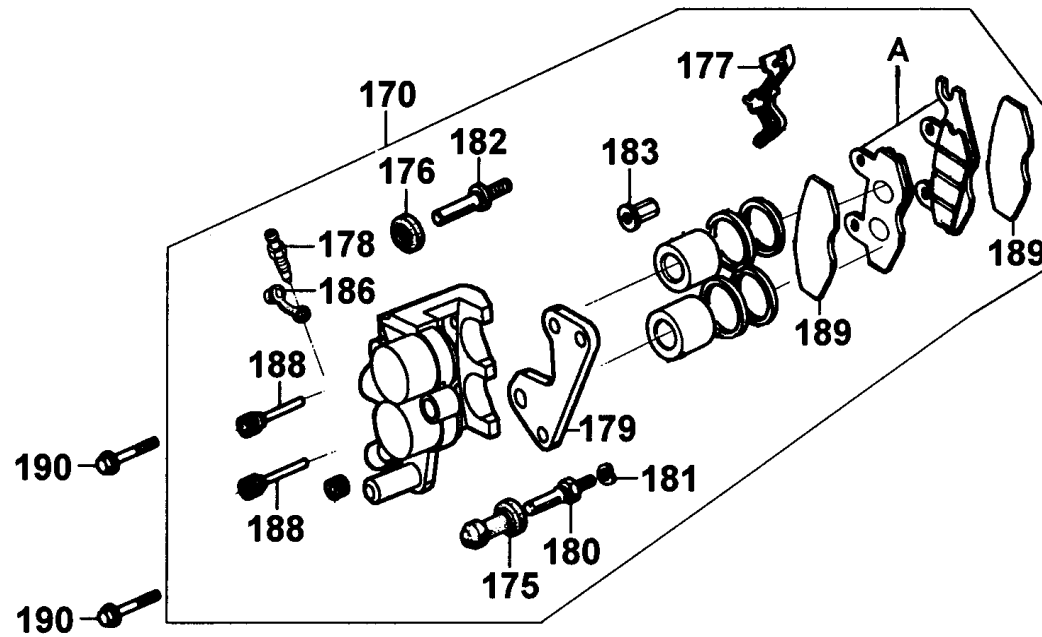

販賣記號	項目	零件號碼	版數	英文名稱	中文名稱	需要用量	參考價
Sales mark	Ref no	Part no	Ver	Description	Chinese	Regd no	Ref Price
**	170	45200-KEC8-9000	0	CALIPER ASSY FR	前煞車卡鉗	1	
*	175	45132-166-0160	0	BUSH BOOT PIN	襯套	1	
*	176	45133-MA3-0060	0	BOOT B	襯套 B	1	
*	177	45108-ML4-0060	2	PAD SPG	摩擦板彈簧	1	
*	178	43352-568-0030	3	SCREW BLEEDER	加油嘴	1	
*	179	45210-KEC8-9000	0	BRACKET FR	前煞車卡鉗托架	1	
*	180	45131-166-0160	0	PIN BOLT	螺絲銷	1	
*	181	45216-166-0060	0	WASHER WAVE	華司	1	
*	182	45131-GE2-0060	1	PIN BOLT A	螺絲銷 A	1	
*	183	45216-KW6-9010-M1	0	TORQUE NUT	螺帽	1	
*	186	43353-461-7710-M1	0	CAP BLEEDER	加油嘴蓋	1	
*	188	45215-KCE-9000	0	PIN HANGER	吊架銷	1	
*	189	43215-KBE-9000	0	PAD HANGER	吊架摩擦板	1	
*	190	90122-KEC8-9000	0	BOLT FLANGE 8*38	螺絲	2	
*	A	45150-KEC8-3050	0	PAD ASSY A/B	煞車摩擦板組	1	

F 8 Front Wheel

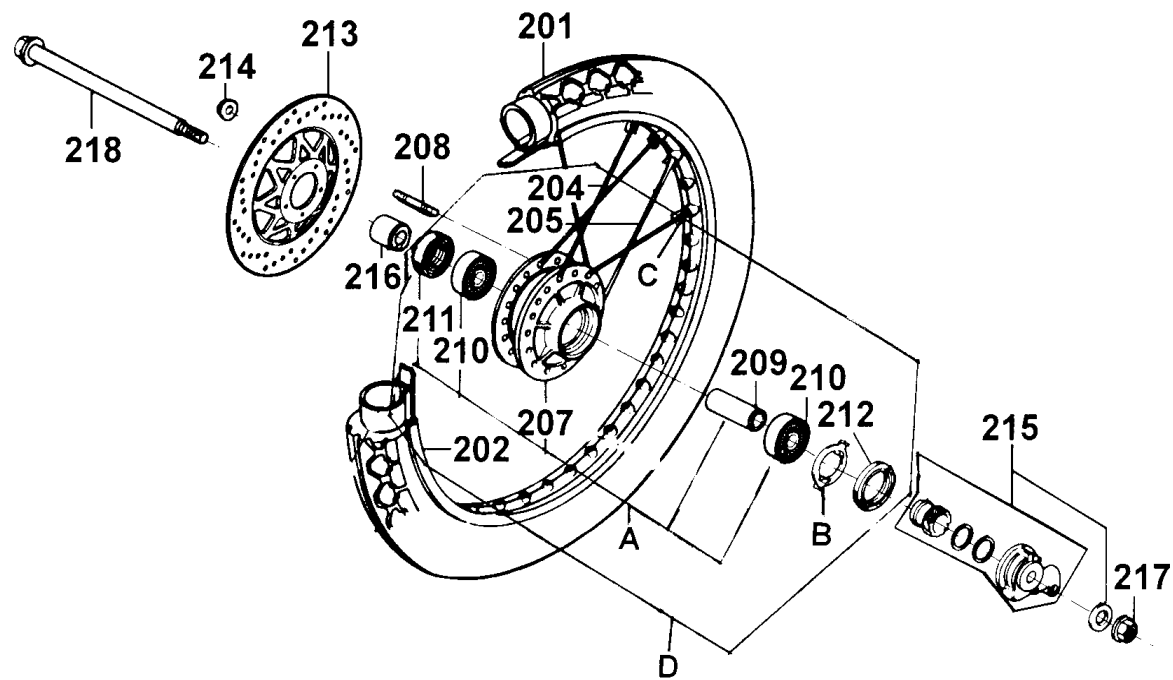

販賣記號	項目	零件號碼	版數	英文名稱	中文名稱	需要用量	參考價
Sales mark	Ref no	Part no	Ver	Description	Chinese	Regd no	Ref Price
*	201	44710-KEC8-9000-M1	0	TIRE ASSY FRONT	前輪胎	1	
*	202	44701-KAL-9000	0	RIM FRONT WHEEL	前輪鋼圈	1	
*	204	44721-KAK-9000	0	SPOKE A FR	鋼絲	18	
*	205	44722-KAK-9000	0	SPOKE B FR	鋼絲	18	
	207	44601-KG7-9000	0	HUB FR WHEEL	前輪殼	1	
*	208	92912-06018-0E	0	BOLT STUD 6*18	雙頭螺絲	5	
*	209	44620-400-0000	1	COLLAR FR DIST	前輪邊套筒	1	
*	210	96140-63010-10	0	BEARING BALL RADIAL 6301 U	軸承 6301	2	
*	211	91252-030-0000	0	OIL SEAL WHEEL 23*37*7	油封 23X37X7	1	
*	212	91258-410-0000-M2	0	DUST SEAL 4.0*50*5	防塵封 4.0X50X5	1	
*	213	45121-KW6-9010	1	DISK FRONT BRAKE	煞車摩擦圓盤	1	
*	214	90301-473-0040	0	NUT U 6MM	螺帽 6MM	5	
*	215	44800-KEC8-9000	0	GEAR BOX ASSY SPDMT	速度齒輪箱組	1	
*	216	44311-KAK-9000	0	COLLAR FR SIDE WHEEL	前輪邊套筒	1	
*	217	90306-GW0-9020	0	NUT U FLANGE 12MM	螺帽 12MM	1	
*	218	44301-KW6-9010	1	AXLE FR WHEEL	前輪軸	1	
*	A	4460A-KEC8-9000	0	HUB ASSY FR WHEEL	前輪殼組	1	
*	B	44680-410-0010	0	RETAINER GEAR BOX	速度齒輪箱承盤	1	
*	C	97000-KAL-9100	1	NIPPLE SPOKE 10#	鋼絲接頭	36	
*	D	4460B-KEC8-9000	0	WHEEL SET B FR	前輪組	1	

F 8

F 9 Rear Brake Panel

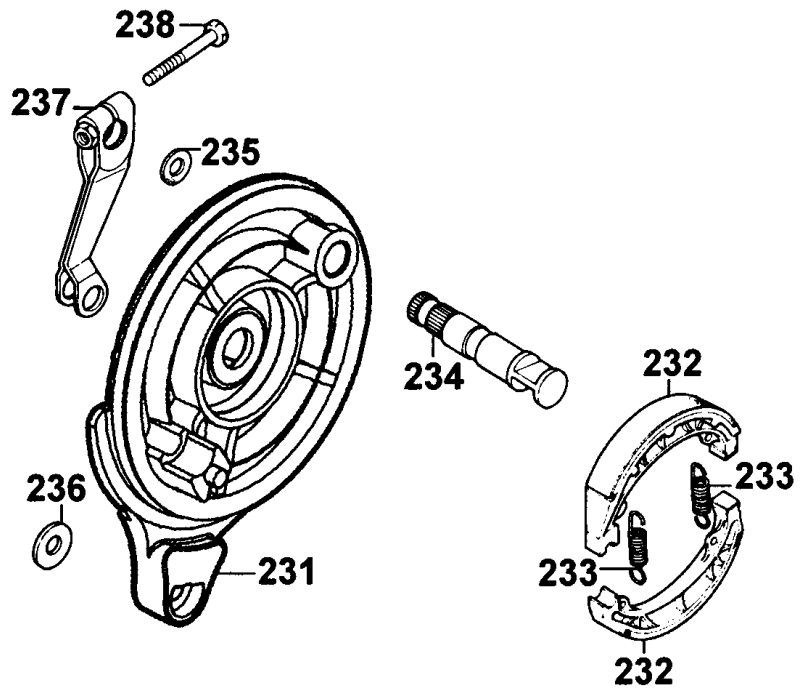

販賣記號	項目	零件號碼	版數	英文名稱	中文名稱	需要用量	參考價
Sales mark	Ref no	Part no	Ver	Description	Chinese	Regd no	Ref Price
*	231	43100-KG7-8310	1	PANEL COMP REAR BRAKE	後剎車板	1	
*	232	43120-KG7-0020	0	SHOE COMP REAR BRAKE	後剎車鞋	2	
*	233	45133-240-0000	1	SPRING FRONT BRAKE SHOE	剎車鞋彈簧	2	
*	234	43141-KEC8-9000	0	CAM REAR BRAKE	後煞車凸輪	1	
*	235	45134-250-0000	0	BRAKE CAM DUST SEAL	凸輪防塵封	1	
*	236	90549-121-0000	0	WASHER PLAIN 14M/M	華司 14MM	1	
*	237	43410-KEC8-9000	0	ARM REAR BRAKE	後煞車臂	1	
*	238	95701-06022-08	0	BOLT FLANGE 6*22	螺絲 6X22	1	

F 10 Rear Wheel

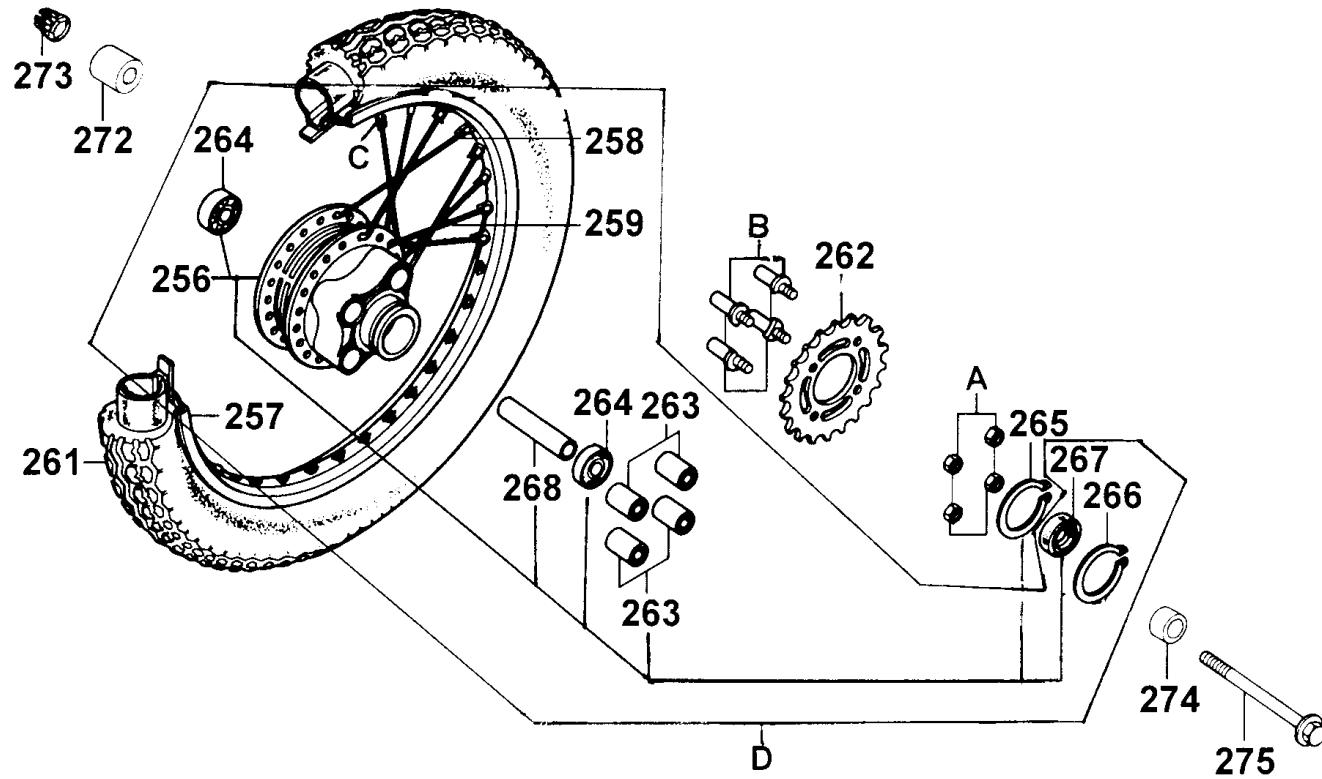

販賣記號	項目	零件號碼	版數	英文名稱	中文名稱	需要用量	參考價
Sales mark	Ref no	Part no	Ver	Description	Chinese	Regd no	Ref Price
*	256	42600-KEC8-3050	0	WHEEL SET RR	後輪圈	1	
*	257	42701-KEC8-8000	0	RIM RR WHEEL	後輪鋼圈	1	
*	258	97612-62130-10	0	SPOKE B8*145	鋼絲	18	
*	259	97874-62129-10	0	SPOKE B8*144.5	鋼絲	18	
*	261	42710-KEC8-9000-M1	0	TIRE ASSY REAR	外胎	1	
*	262	41201-KEC8-9000	0	SPROCKET FINAL	後齒輪	1	
*	263	41241-307-0110	0	BUSH RR WHEEL DAMPER	後輪襯套	4	
*	264	96140-63030-10	0	BEARING BALL RADIAL 6303U	軸承 6303	2	
*	265	90664-216-9000	0	CIR CLIP 58MM	環夾 58MM	1	
*	266	94524-47000	0	CIR CLIP EX 47MM	夾子 47MM	1	
*	267	90757-439-9310	0	DUST SEAL REAR WHEEL	油封	1	
*	268	42620-KEC2-9000	0	COLLAR REAR AXLE DISTANCE	後輪軸套筒	1	
*	272	42311-KEC8-9000	0	COLLAR RR BRAKE PANEL SIDE	後煞車邊套筒	1	
*	273	90305-KW6-9120-M1	0	NUT U FLANGE 16MM	螺帽 16MM	1	
*	274	42313-KEC8-9000	0	COLLAR RR WHEEL R	後輪邊套筒	1	
*	275	42301-KEC8-9000	0	AXLE REAR WHEEL	後輪軸	1	
*	A	94031-10080	0	NUT HEX 10MM	螺帽	4	
*	B	90128-KEC8-9000	0	PIN SPRKT FIX	後齒輪螺絲	4	
*	C	97000-56200	0	NIPPLE SPOKE 9#	鋼絲接頭	36	
*	D	42600-KEC8-3150	0	WHEEL SET B RR	後輪組	1	

F 11 Fuel Tank●Fuel Meter

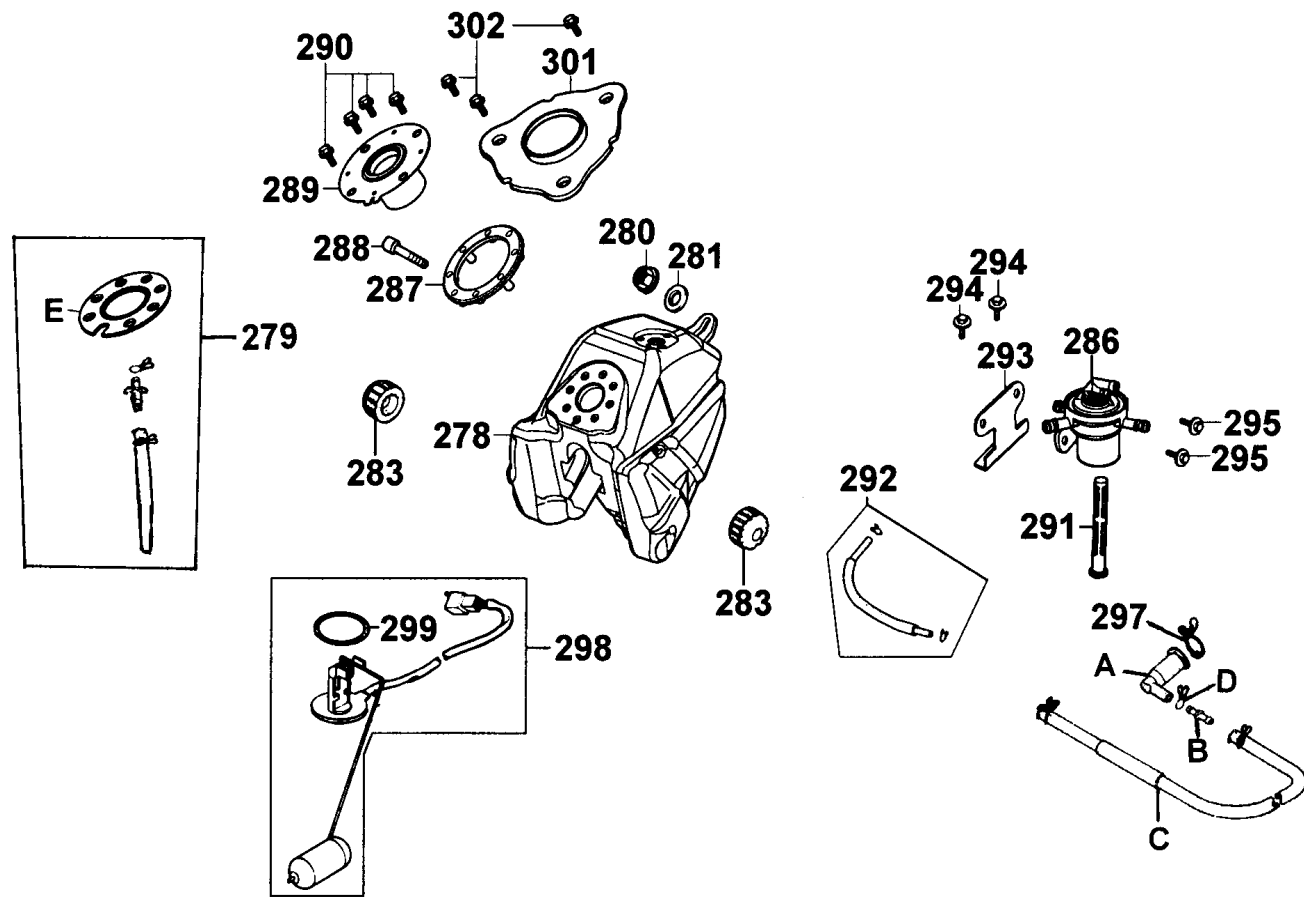

販賣記號	項目	零件號碼	版數	英文名稱	中文名稱	需要用量	參考價
Sales mark	Ref no	Part no	Ver	Description	Chinese	Regd no	Ref Price
*	278	17510-KEC8-E000	0	TANK SET FUEL	油箱組	1	
*	279	1752A-KEC8-9000	0	TRAY CAP ASSY	油箱蓋托蓋組	1	
*	280	94050-08080	0	NUT FLANGE 8MM	螺帽 8MM	1	
*	281	94101-12800	0	WASHER PLAIN 12MM	華司 12MM	1	
*	283	17611-286-0000	0	CUSHION FRONT FUEL TANK	油箱減震橡皮	2	
*	286	16950-KEC8-9000	0	AUTO COCK ASSY FUEL	油杯	1	
*	287	17505-KEC8-9000	0	RING COMP CAP HOUSING	托蓋固定座	1	
*	288	90103-KEC8-9000	0	SOCKET BOLT 5*25	螺絲	1	
*	289	17504-KEC8-E000	0	FILLER COMP FUEL	油箱蓋	1	
*	290	90302-GY6-9010	0	BOLT WASH 5*12	螺絲 5X12	4	
*	291	16952-KEC8-9000	0	SCREEN FUEL STRAINER	油杯過濾網	1	
*	292	9500C-KEC8-9000	0	TUBE ASSY FUEL	油管	1	
*	293	16920-KEC8-8000	0	STAY AUTO COCK	油杯座	1	
*	294	90302-GY6-9010	0	BOLT-WASHER 5*12	螺絲 5X12	2	
*	295	90302-GY6-9400	0	BOLT-WASHER 5*16	螺絲 5X16	2	
*	297	15772-551-0000	1	CLIP BREATHER TUBE	油管夾	1	
*	298	3780A-KEC8-9000	0	FUEL UNIT ASSY	燃料量指示器組	1	
*	299	37801-GA7-7000	1	PACKING BASE	油封	1	
*	301	37802-KEC8-9000	0	RET FUEL UNIT	浮筒計承座	1	
*	302	90302-GY6-9010	0	BOLT WASH 5*12	螺絲 5X12	3	

F 11

F 11 Fuel Tank●Fuel Meter

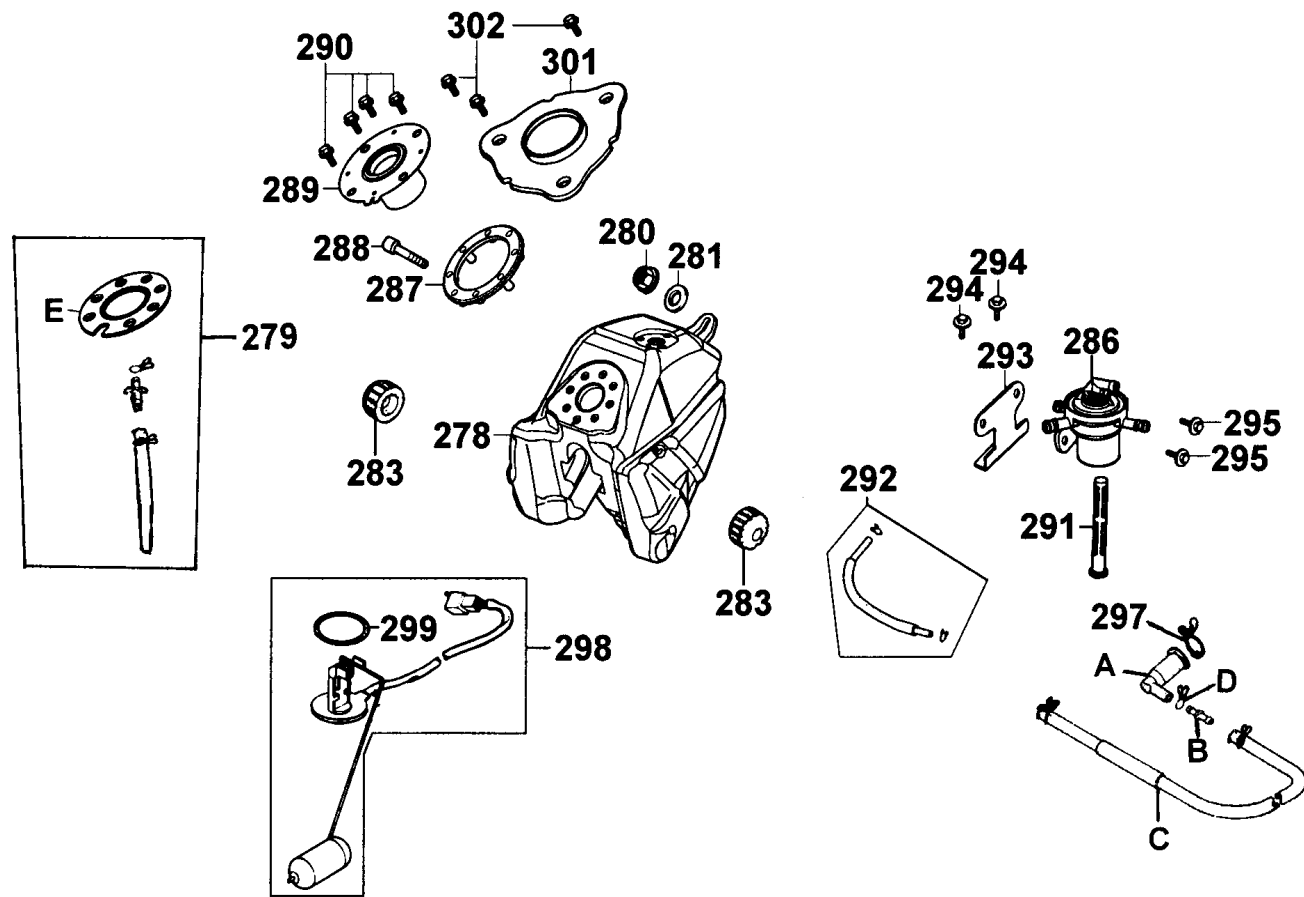

販賣記號	項目	零件號碼	版數	英文名稱	中文名稱	需要用量	參考價
Sales mark	Ref no	Part no	Ver	Description	Chinese	Regd no	Ref Price
*	A	16960-KEC8-9000	0	JOINT FUEL STRN	油杯護套	1	
*	B	55102-166-0010	0	JOINT OIL TUBE	接頭	1	
*	C	16955-KEC8-9000	0	TUBE ASSY FUEL	油管組	1	
*	D	95002-50000	0	CLIP C9 TUBE	油管夾	1	
*	E	17520-KEC8-9000	0	PACKING FUEL TANK	油箱蓋托蓋	1	

F 11

F 12 Seat

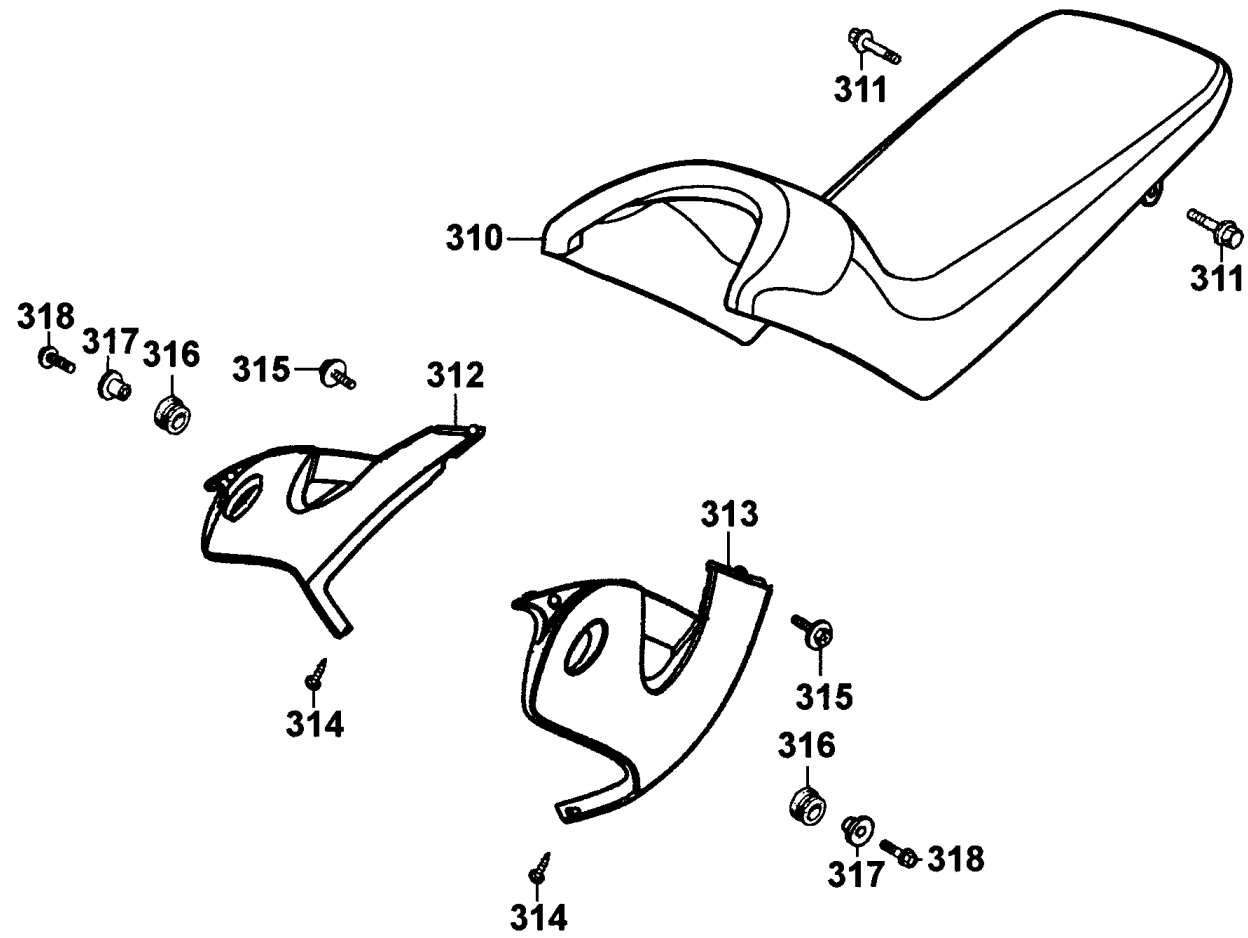

販賣記號	項目	零件號碼	版數	英文名稱	中文名稱	需要用量	參考價
Sales mark	Ref no	Part no	Ver	Description	Chinese	Regd no	Ref Price
**	310	77200-KEC8-9000	0	SEAT ASSY	座墊	1	
*	311	90111-KEC8-9000	0	BOLT FLANGE 6MM	螺絲 6MM	2	
**	312	77115-KEC8-3050-GM	0	COWL R UNDER	右下擋泥板	1	
**	313	77116-KEC8-3050-GM	0	COWL L UNDER	左下擋泥板	1	
*	314	90110-GW0-0010	1	SCREW SPECIAL 6*14	螺絲 6X14	2	
*	315	90302-KEC8-9000	0	BOLT PAN 5*9	螺絲 5X9	2	
*	316	83551-KEC8-9000	0	GROMMET COVER	索環	2	
*	317	83550-KEC8-9000	0	COLLAR	套筒	2	
*	318	95701-06020-08	0	BOLT FLANGE 6*20	螺絲	2	

F 12

F 13 Side Cover

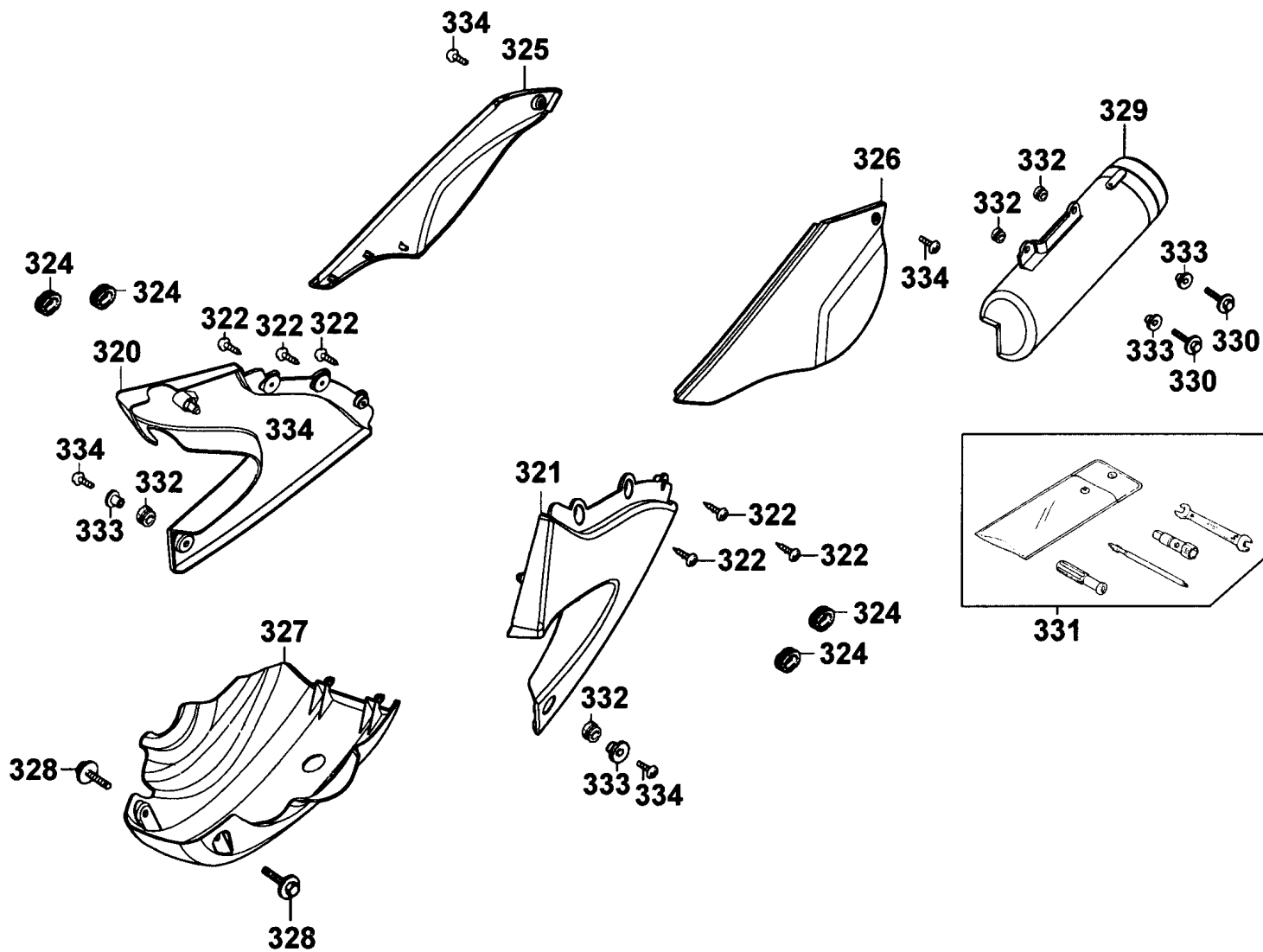

販賣記號	項目	零件號碼	版數	英文名稱	中文名稱	需要用量	參考價
Sales mark	Ref no	Part no	Ver	Description	Chinese	Regd no	Ref Price
**	320	83500-KEC8-9000	0	COVER R BODY A	右邊蓋 A	1	
**	321	83600-KEC8-9000	0	COVER L BODY A	左邊蓋 A	1	
*	322	93903-34380	0	SCREW TAPPING 4*12	螺釘 4X12	6	
*	324	83551-KAK-9000	0	GROMMET AIR CCLEANER CASE	橡皮	4	
**	325	83510-KEC8-3050-GM	0	COVER R BODY B	右邊蓋 B	1	
**	326	83610-KEC8-3050-GM	0	COVER L BODY B	左邊蓋 B	1	
**	327	50613-KEC8-9000	0	COVER UNDER	下擋泥板	1	
*	328	90302-GY6-9010	0	BOLT WASH 5*12	螺絲 5X12	2	
*	329	8910A-KEC8-9000	0	TOOL BOX ASSY	工具箱	1	
*	330	90302-GY6-9010	0	BOLT WASH 5*12	螺絲 5X12	2	
*	331	89010-KN7-C000	0	TOOL SET	工具包	1	
*	332	83551-KEC8-9000	0	GROMMET COVER	索環	2	
*	333	83550-KEC8-9000	0	COLLAR	套筒	2	
*	334	90112-KEC8-9000	0	SCREW SPECIAL 6*20	螺絲	2	

F 14 Air Cleaner

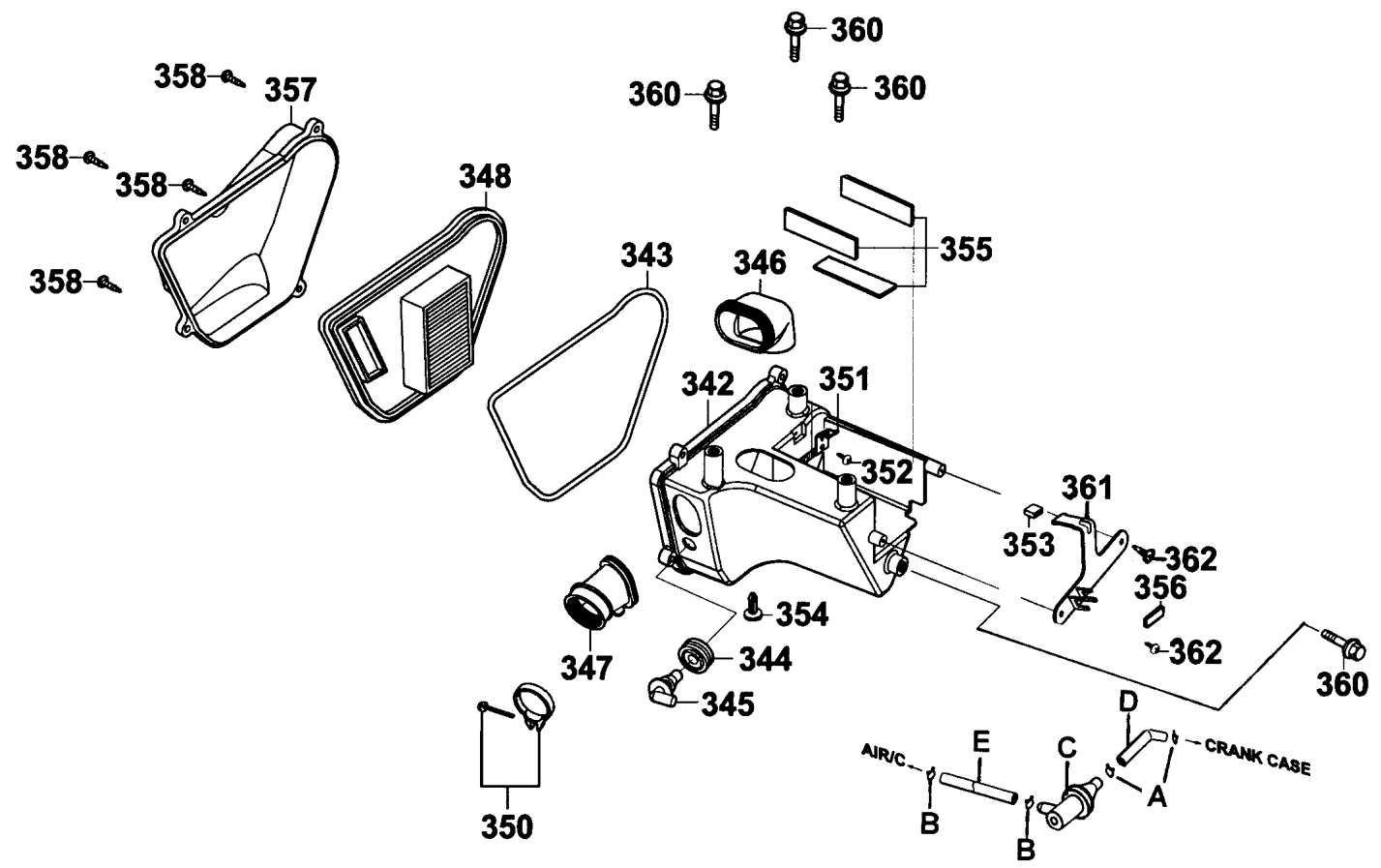

販賣記號	項目	零件號碼	版數	英文名稱	中文名稱	需要用量	參考價
Sales mark	Ref no	Part no	Ver	Description	Chinese	Regd no	Ref Price
*	342	17229-KEC8-9000	0	CASE COMP AIR/C	空氣濾清箱	1	
*	343	17226-KEC8-9000	0	SEAL AIR/C	空氣濾清器防水封	1	
*	344	17266-KG7-0010	0	PACKING ACV JOINT	防水封	1	
*	345	17265-KG7-0010	0	JOINT BLOW BY	空氣濾清箱接頭	1	
*	346	17219-KEC8-9000	0	DUCT AIR	空氣導入口	1	
*	347	17253-KEC8-9000	0	TUBE AIR/C CONN	連接管	1	
*	348	17211-KEC8-9000	0	ELEMENT AIR/C	空氣濾清器海綿	1	
*	350	90652-GY6-9000	2	BAND 49 AIR/C CONNECTING TUBE	連接管固定帶	1	
*	351	17236-KEC8-9000	0	STAY B BATTERY	電瓶座 B	1	
*	352	93903-25380	0	SCREW TAPPING 5*16	螺釘 5X16	1	
*	353	50174-KEC8-9000	0	RUBBER BATTERY STAY	電瓶座橡皮	1	
*	354	17236-KBF-9000	0	PLATE	銷	1	
*	355	50321-KG7-0000	0	CUSHION RUBBER A	橡皮	3	
*	356	50322-KG7-0000	0	CUSHION RUBBER B	橡皮 B	1	
*	357	17228-KEC8-9000	0	COVER AIR/C CASE	空氣濾清箱蓋	1	
*	358	93891-05016-0H	0	SCREW WASHER 5*16	螺絲 5X16	4	
*	360	95701-06012-08	0	BOLT FLANGE 6*12	螺絲 6X12	4	
*	361	50173-KEC8-9000	0	STAY A BATTERY	電瓶座 A	1	
*	362	93891-05012-08	0	SCREW WASHER 5*12	螺絲 5X12	2	
*	A	15772-292-0100	0	CLIP BREATHER TUBE	管夾	2	

F 14 Air Cleaner

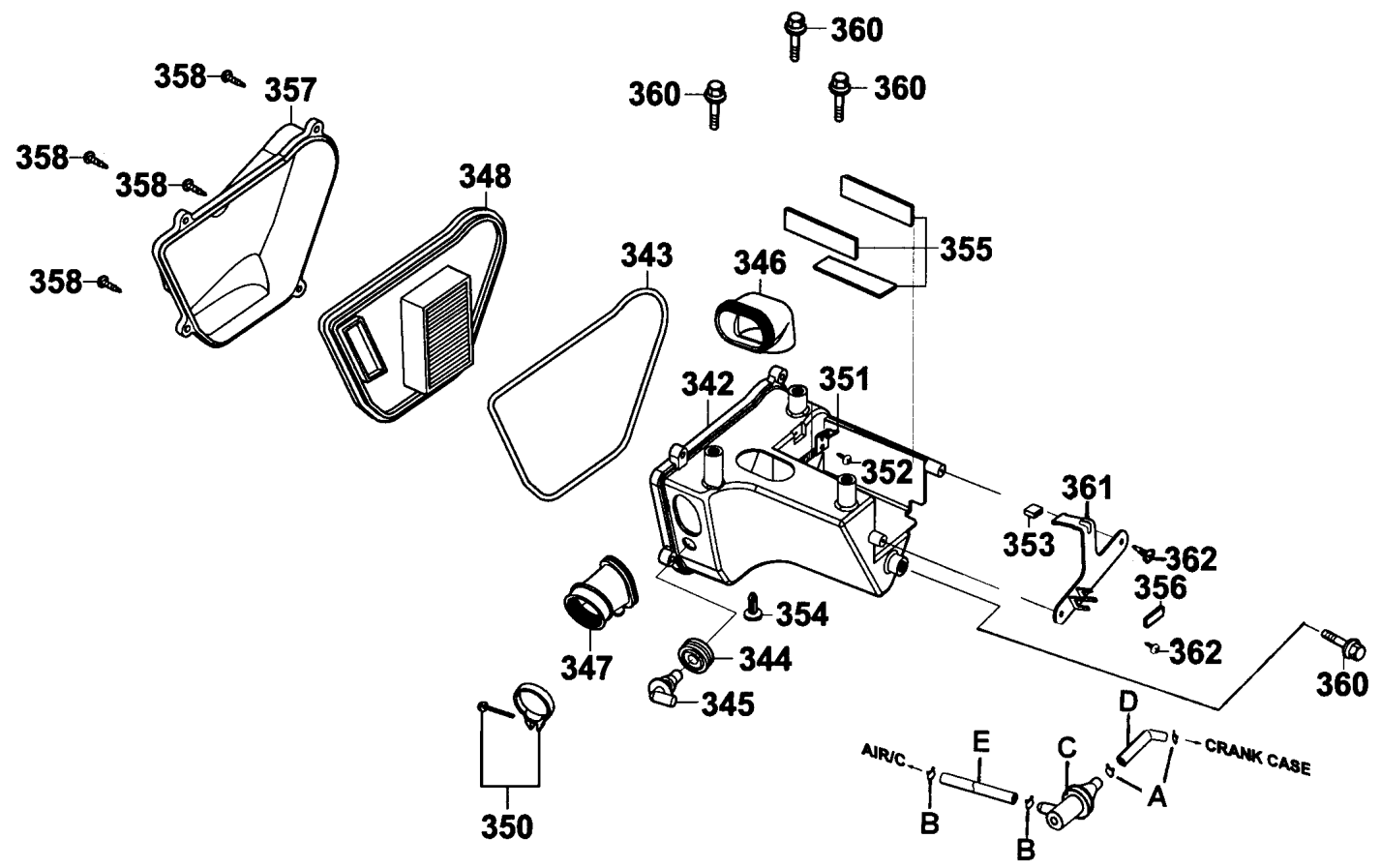

販賣記號	項目	零件號碼	版數	英文名稱	中文名稱	需要用量	參考價
Sales mark	Ref no	Part no	Ver	Description	Chinese	Regd no	Ref Price
*	B	95002-02120	0	CLIP B12 TUBE	管夾 B12	2	
*	C	17360-GE1-9000	2	CATCH TANK ASSY	曲軸箱廢氣回收器	1	
*	D	95005-KG7-9000	1	TUBE A	通氣管 A	1	
*	E	11108-KEC8-9000	0	TUBE B	通氣管 B	1	

F 14

F 15 Exhaust Muffler

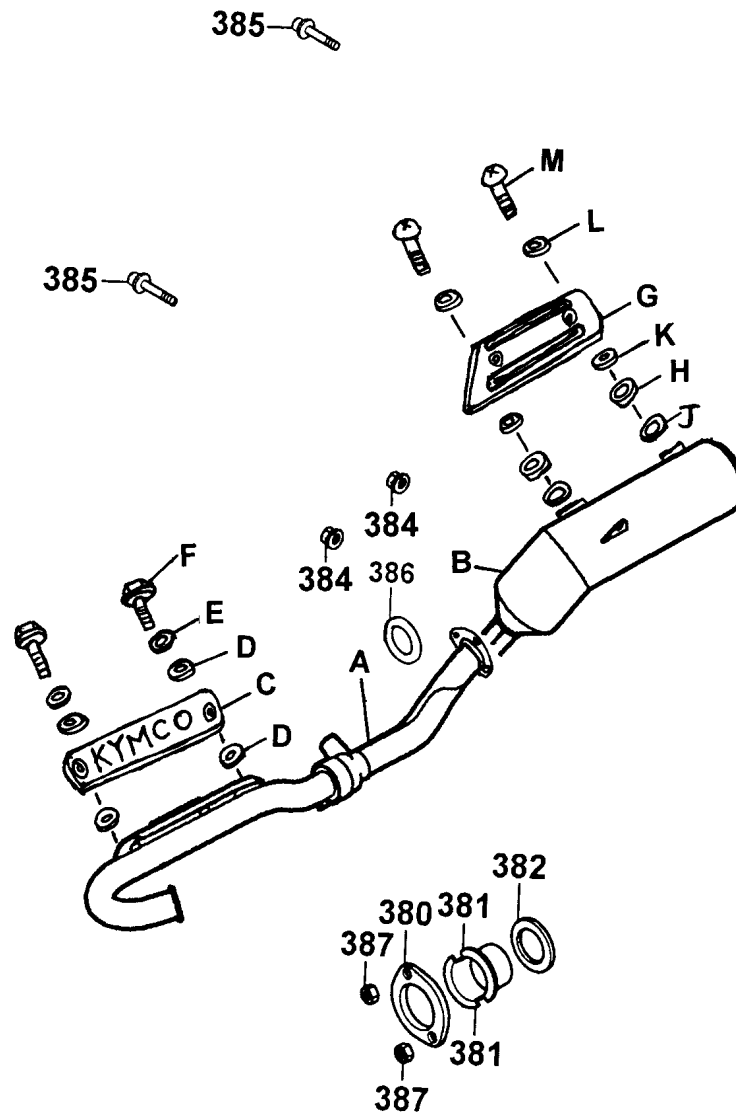

販賣記號	項目	零件號碼	版數	英文名稱	中文名稱	需要用量	參考價
Sales mark	Ref no	Part no	Ver	Description	Chinese	Regd no	Ref Price
*	380	18231-365-6700	1	JOINT EXH PIPE	排氣管接頭	1	
*	381	18233-383-9000	1	COLLAR EXHAUST PIPE JOINT	接頭套筒	2	
*	382	18291-166-0030	0	GASKET EXH PIPE	排氣管墊圈	1	
*	384	94001-06080-0S	0	NUT HEX 6MM	螺帽 6MM	3	
*	385	95701-08012-08	0	BOLT FLANGE 8*12	螺絲 8X12	2	
*	386	18291-216-0000	1	GASKET EXH PIPE	排氣管墊圈	1	
*	387	94050-06080	0	NUT FLANGE 6MM	螺帽 6MM	2	
*	A	18320-KEC8-E000	0	PIPE COMP EXH	排氣管接管	1	
*	B	18310-KEC8-E000	0	MUFFLER COMP	排氣管	1	
*	C	18321-KEC8-9000	0	PROTECTOR EXH PIPE	排氣接管護蓋	1	
*	D	18294-KCT-9000	0	PACKING PROTECTOR	墊片	4	
*	E	94101-06000	0	WASHER PLAIN 6MM	華司 6MM	2	
*	F	96001-06016-02	0	BOLT FLANGE 6*16	螺絲 6MM	2	
*	G	18318-KEC8-9000	0	PROTECTOR MUFF BODY	排氣管護蓋	1	
*	H	18291-KEC8-9000	0	COLLOR	套筒	2	
*	J	18294-KEC8-9000	0	PACKING PROTECTOR	墊片	2	
*	K	18293-KEC8-9000	0	RUBBER PKG PROTECTOR	橡皮	2	
*	L	18292-KEC8-9000	0	PACKING PROTECTOR	墊片	2	
*	M	90110-KBE-9000	0	SCREW SPECIAL 6*22	螺絲 6MM	2	

F 16 Pedal●Stand

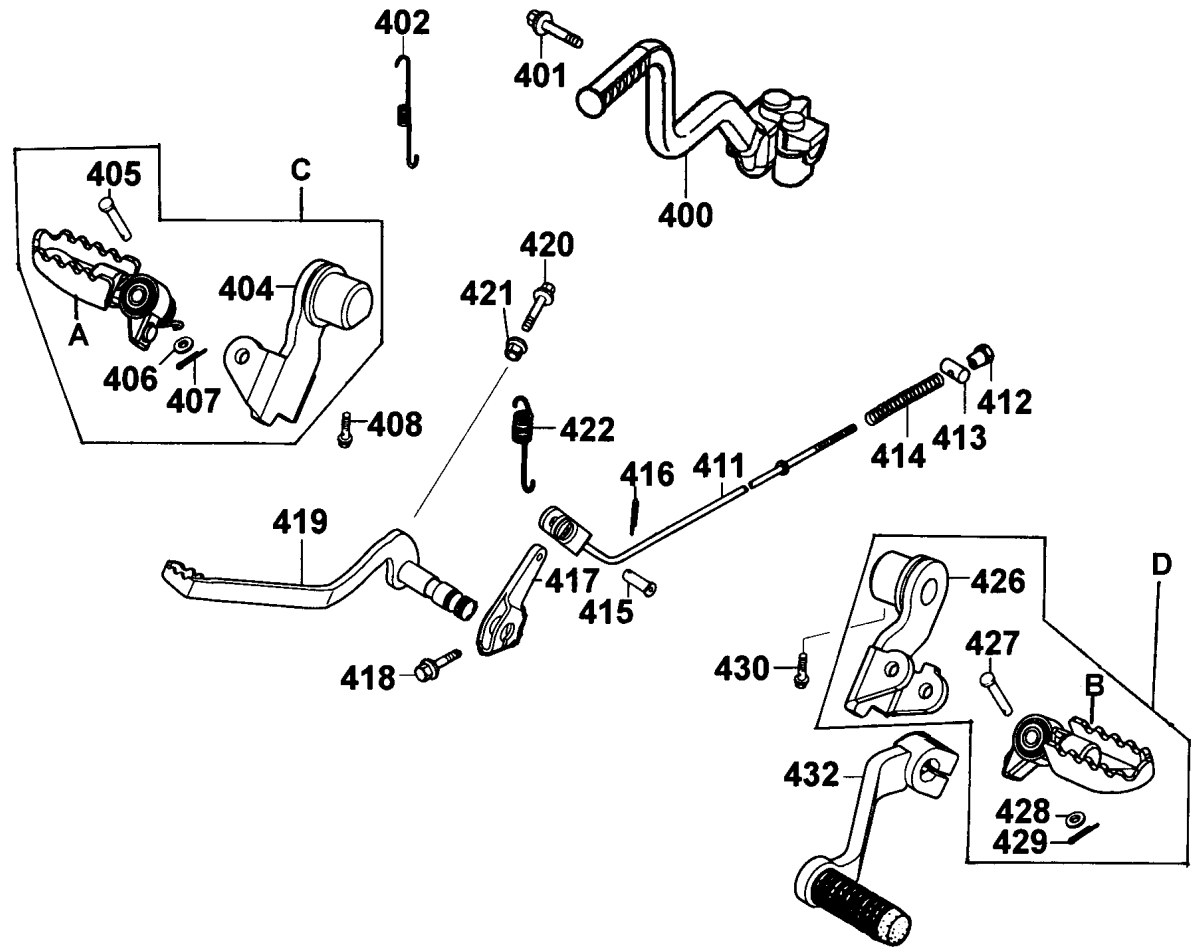

販賣記號	項目	零件號碼	版數	英文名稱	中文名稱	需要用量	參考價
Sales mark	Ref no	Part no	Ver	Description	Chinese	Regd no	Ref Price
*	400	2830A-KEC8-8000	0	ARM ASSY KICK	起動踏桿組	1	
*	401	95701-08035-08	0	BOLT FLANGE 8*35	螺絲 8X35	1	
*	402	35357-KEC8-9000	0	SPRING STOP SWITCH	後置開關回位彈簧	1	
*	404	50133-KEC8-9000-H1	0	BRKT R FR STEP	右前腳踏桿	1	
*	405	95015-KEC8-9000	0	PIN P STEP	插銷	1	
*	406	94101-08800	0	WASHER PLAIN 8MM	華司 8MM	1	
*	407	94251-08400	0	PIN LOCK 8MM	銷 8MM	1	
*	408	90131-KBE-9000	0	BOLT FLANGE 8*24	螺絲 8MM	1	
*	411	43451-KEC8-9000	0	ROD RR BRAKE	後煞車連桿	1	
*	412	95015-42000	0	NUT B ADJUST	調節螺帽	1	
*	413	95015-32001	0	JOINT B BRAKE ARM	調節接頭	1	
*	414	95014-73100	0	SPRING BRAKE ROD	後煞車連桿彈簧	1	
*	415	43452-KEC8-9000	0	BRAKE ROD JOINT PIN	後煞車連桿插銷	1	
*	416	94201-20120	0	PIN SPLIT	銷 8MM	1	
*	417	46503-KEC8-9000	0	ARM RR BRAKE PEDAL	後煞車踏桿臂	1	
*	418	95801-08040-00	0	BOLT FLANGE 8*40	螺絲 8X40	1	
*	419	46501-KEC8-9000	0	PEDAL COMP RR BRAKE	後煞車踏桿	1	
*	420	92201-06030-0A	0	BOLT HEX 6*30	螺絲 6X30	1	
*	421	94001-06000-0S	0	NUT HEX 6MM	螺帽 6MM	1	
*	422	46514-KEC8-9000	0	SPRING BRAKE RETURN	後煞車桿回位彈簧	1	

F 16 Pedal●Stand

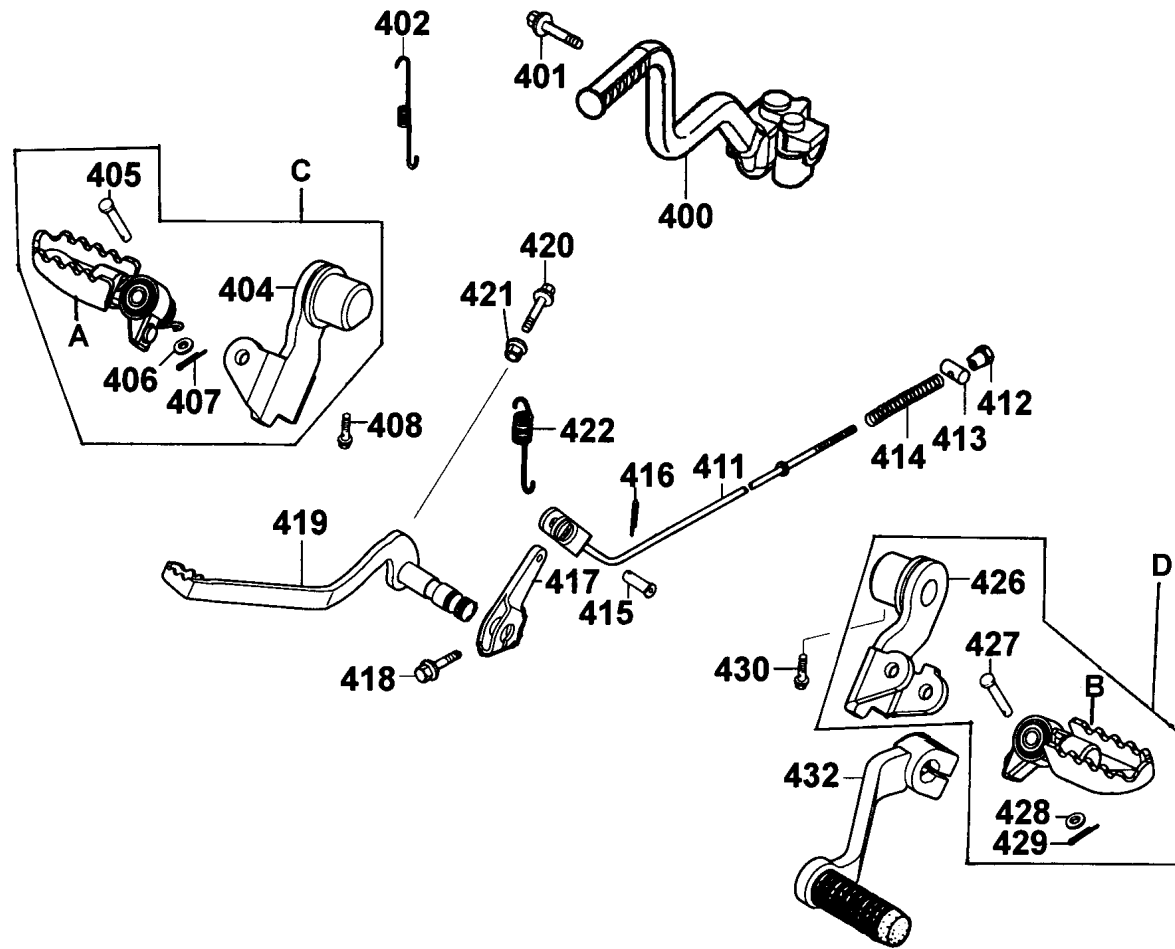

販賣記號	項目	零件號碼	版數	英文名稱	中文名稱	需要用量	參考價
Sales mark	Ref no	Part no	Ver	Description	Chinese	Regd no	Ref Price
*	426	50134-KEC8-9000-H1	0	BRKT L FR STEP	左前腳踏桿	1	
*	427	95015-KEC8-9000	0	PIN P STEP	插銷	1	
*	428	94101-08800	0	WASHER PLAIN 8MM	華司 8MM	1	
*	429	94251-08400	0	PIN LOCK 8MM	銷 8MM	1	
*	430	90131-KBE-9000	0	BOLT FLANGE 8*24	螺絲 8MM	1	
*	432	24700-KEC8-9000	0	PEDAL ASSY CHNG	變速踏桿	1	
*	A	50630-KEC8-9000	0	STEP COMP R MAIN	右踏板	1	
*	B	50640-KEC8-9000	0	STEP COMP L MAIN	左踏板	1	
*	C	5063A-KEC8-9000	0	STEP ASSY R MAIN	右踏板組	1	
*	D	5064A-KEC8-9000	0	STEP ASSY L MAIN	左踏板組	1	

F 17 Rear Fork●Chain Case

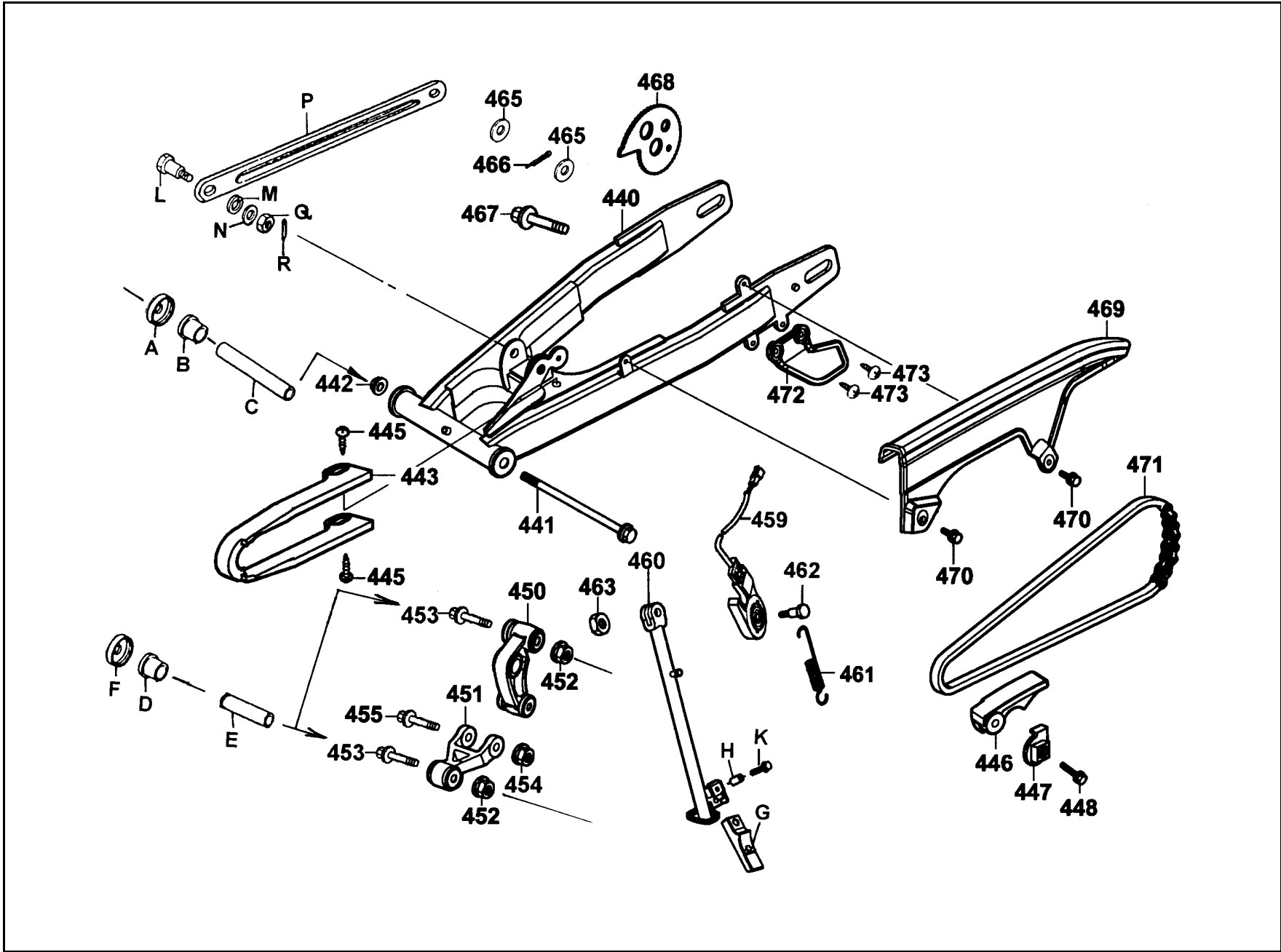

販賣記號	項目	零件號碼	版數	英文名稱	中文名稱	需要用量	參考價
Sales mark	Ref no	Part no	Ver	Description	Chinese	Regd no	Ref Price
*	440	52110-KEC8-9000	0	FORK COMP REAR	後叉	1	
*	441	90121-KEC8-9000	0	BOLT RR FORK	後叉樞軸螺絲	1	
*	442	90305-GE8-0030	0	NUT FLANGE 12MM	螺帽 12MM	1	
*	443	52171-KEC8-9000	0	SLIDER CHAIN	外鏈條導件	1	
*	445	93891-06012-07	0	SCREW WASHER 6*12	螺釘 6X12	2	
*	446	52172-KEC8-9000	0	SLIDER UNDER	鏈條固定座	1	
*	447	52173-KEC8-9000	0	NUT SLIDER UNDER	鏈條調整器螺帽	1	
*	448	95801-08040-00	0	BOLT FLANGE 8*40	螺絲 8X40	1	
*	450	52210-KEC8-9000	0	ARM COMP RR CUSHION	後避震器臂	1	
*	451	52310-KEC8-9000	0	LINK COMP RR CUSHION	後避震器吊板	1	
*	452	90304-GE8-0030	0	NUT U 10MM	螺帽 10MM	2	
*	453	95801-10075-08	0	BOLT FLANGE 10*75	螺絲 10X75	2	
*	454	90306-KF0-0040	0	NUT FLANGE 12MM	螺帽 12MM	1	
*	455	95801-12080-08	0	BOLT FLANGE 12*80	螺絲 12X80	1	
*	459	35370-KEC8-E000	0	SW UNIT SIDE STAND	側支架開關	1	
*	460	50530-KEC8-E000	0	SIDE STAND COMP	側支架	1	
*	461	50535-KEC8-E000	0	SPRING COMP SIDE STAND	側支架彈簧	1	
*	462	90108-KEC8-E000	0	SCREW SIDE STAND PIVOT	側支架螺絲	1	
*	463	94002-10080-0S	0	NUT HEX 10MM	螺帽 10MM	1	
*	465	94101-10800	0	WASHER PLAIN 10MM	華司 10MM	2	

F 17 Rear Fork●Chain Case

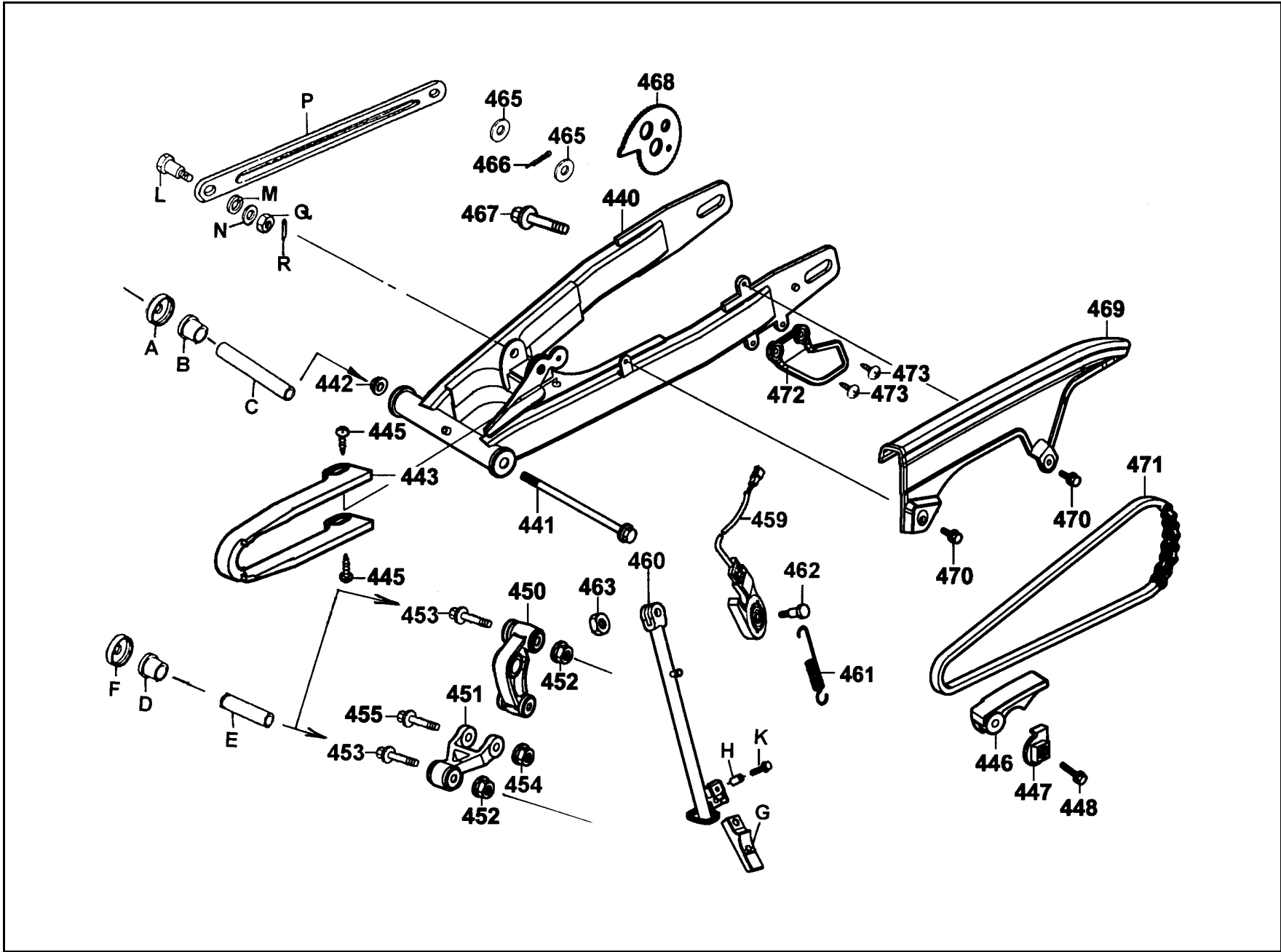

販賣記號	項目	零件號碼	版數	英文名稱	中文名稱	需要用量	參考價
Sales mark	Ref no	Part no	Ver	Description	Chinese	Regd no	Ref Price
*	466	94201-20150	0	PIN SPLIT 2.0*15	開口銷 2.0X15	1	
*	467	92811-KAK-9000	0	BOLT B STPR ARM	螺絲	1	
*	468	40543-KEC8-9000	0	ADJUSTER CHAIN L/R	鏈條調整器	1	
*	469	40510-KEC8-9000	0	CASE UPPER DRIVE CHAIN	外鏈蓋	1	
*	470	90302-GY6-9010	0	BOLT WASH 5*12	螺絲 5X12	2	
*	471	40530-KEC8-9000-M1	0	CHAIN DRIVE	外鏈條	1	
*	471	40530-KEC8-9000-M2	0	CHAIN DRIVE	外鏈條	1	
*	472	40520-KEC8-9000	0	COVER SIDE DRIVE CHAIN	外鏈條邊蓋	1	
*	473	90110-KEB7-9000	0	SCREW SPECIAL 6*14	螺絲 6X14	2	
*	A	52144-GE2-0050	0	CAP RR FORK DUST SEAL	後叉防塵蓋	2	
*	B	52108-KE5-0030	0	BUSH REAR FORK	襯套	2	
*	C	52141-KEC8-9000	0	COLLAR COMP RR FORK	後叉套筒	1	
*	D	52208-KEC8-9000	0	BUSH RR CUSH ARM A	襯套	2	
*	E	52241-KEC8-9000	0	COLLAR RR LINK A	套筒	2	
*	F	52243-KEC8-9000	0	DUST SEAL RR CUSH ARM A	防塵蓋	4	
*	G	50548-324-7600-01	0	RUBBER STAND	側支架橡皮	1	
*	H	50549-356-7000	0	COLLAR STAND RUBBER	套筒	1	
*	K	95799-06025-07	0	BOLT FLANGE 6*25	螺絲 6MM	1	
*	L	92812-KCD-9000	1	RR BRAKE STOPPER ARM BOLT	螺絲	1	
*	M	94111-10800	0	WASHER SPG 10MM	彈簧華司 10MM	1	

F 17

F 17 Rear Fork●Step●Chain Case

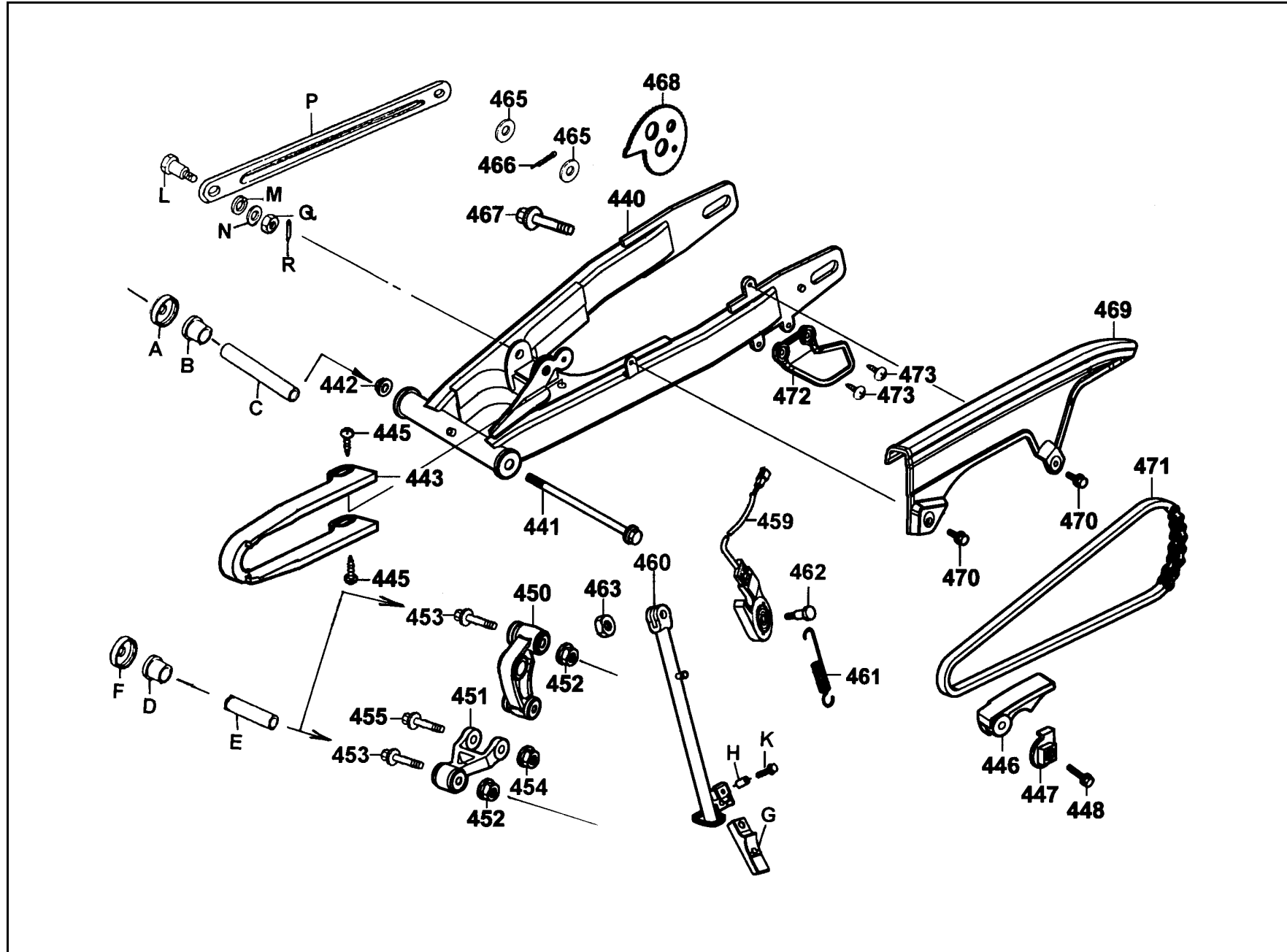

販賣記號	項目	零件號碼	版數	英文名稱	中文名稱	需要用量	參考價
Sales mark	Ref no	Part no	Ver	Description	Chinese	Regd no	Ref Price
*	N	94101-08800	0	WASHER PLAIN 8MM	華司	1	
*	P	43431-KEC8-9000	0	STOPPER ARM RR BRAKE	後煞車制動臂	1	
*	Q	94001-08080-0S	0	NUT HEX 8MM	螺帽 8MM	1	
*	R	94201-20150	0	PIN SPLIT 2.0*15	開口銷 2.0X15	1	

F 17

F 18 Rear Cushion

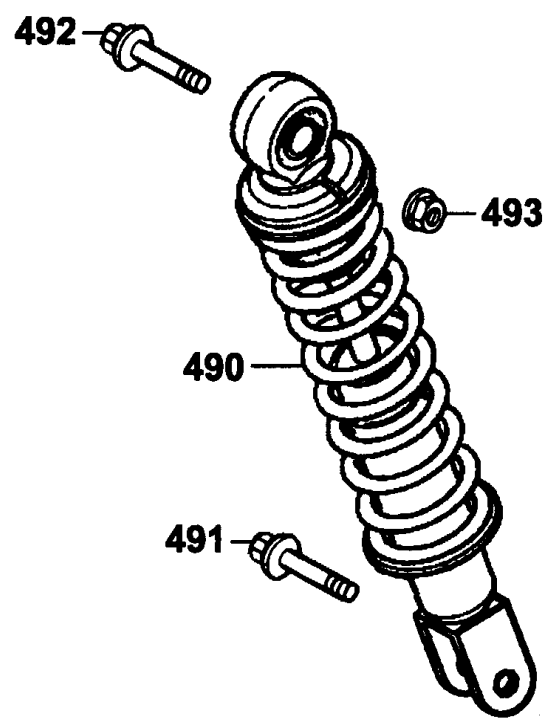

F 18

販賣記號	項目	零件號碼	版數	英文名稱	中文名稱	需要用量	參考價
Sales mark	Ref no	Part no	Ver	Description	Chinese	Regd no	Ref Price
*	490	52400-KKEC8-9000	0	CUSHION ASSY REAR	後避震器組	2	
*	491	95801-10075-08	0	BOLT FLANGE 10*75	螺絲	1	
*	492	95801-10040-08	0	BOLT FLANGE 10*40	螺絲	1	
*	493	94050-10080	0	NUT FLANGE 10MM	螺帽 10MM	1	

F 19 Rear Fender

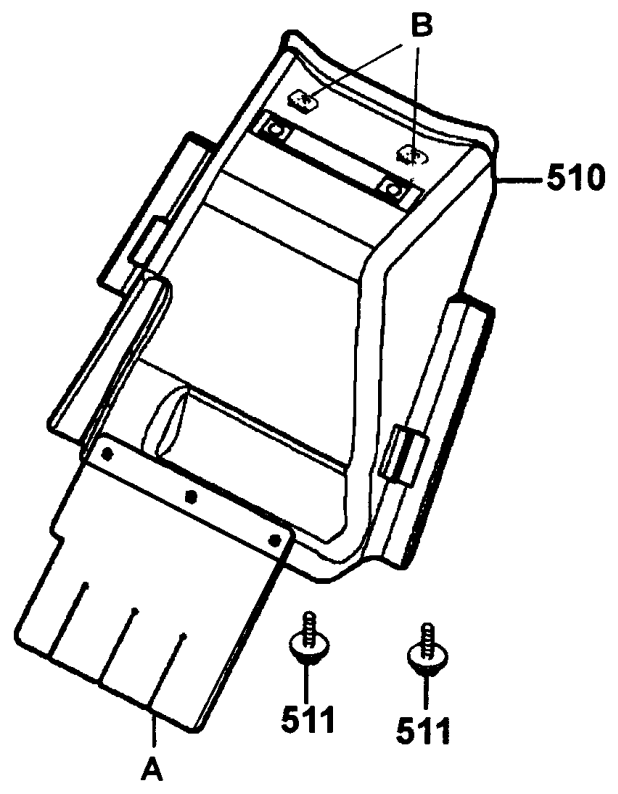

販賣記號	項目	零件號碼	版數	英文名稱	中文名稱	需要用量	參考價
Sales mark	Ref no	Part no	Ver	Description	Chinese	Regd no	Ref Price
*	510	80101-KEC8-8000	0	FENDER A REAR	後土除 A	1	
*	511	90302-GY6-9010	0	BOLT-WASH 5*12	螺絲 5X12	2	
*	A	80102-KEC8-9000	0	PLATE SPLASH GUARD	防濺板	1	
*	B	90677-GR1-0030	1	NUT CLIP 5MM	螺帽夾 5MM	2	

F 19

F 20 Winker

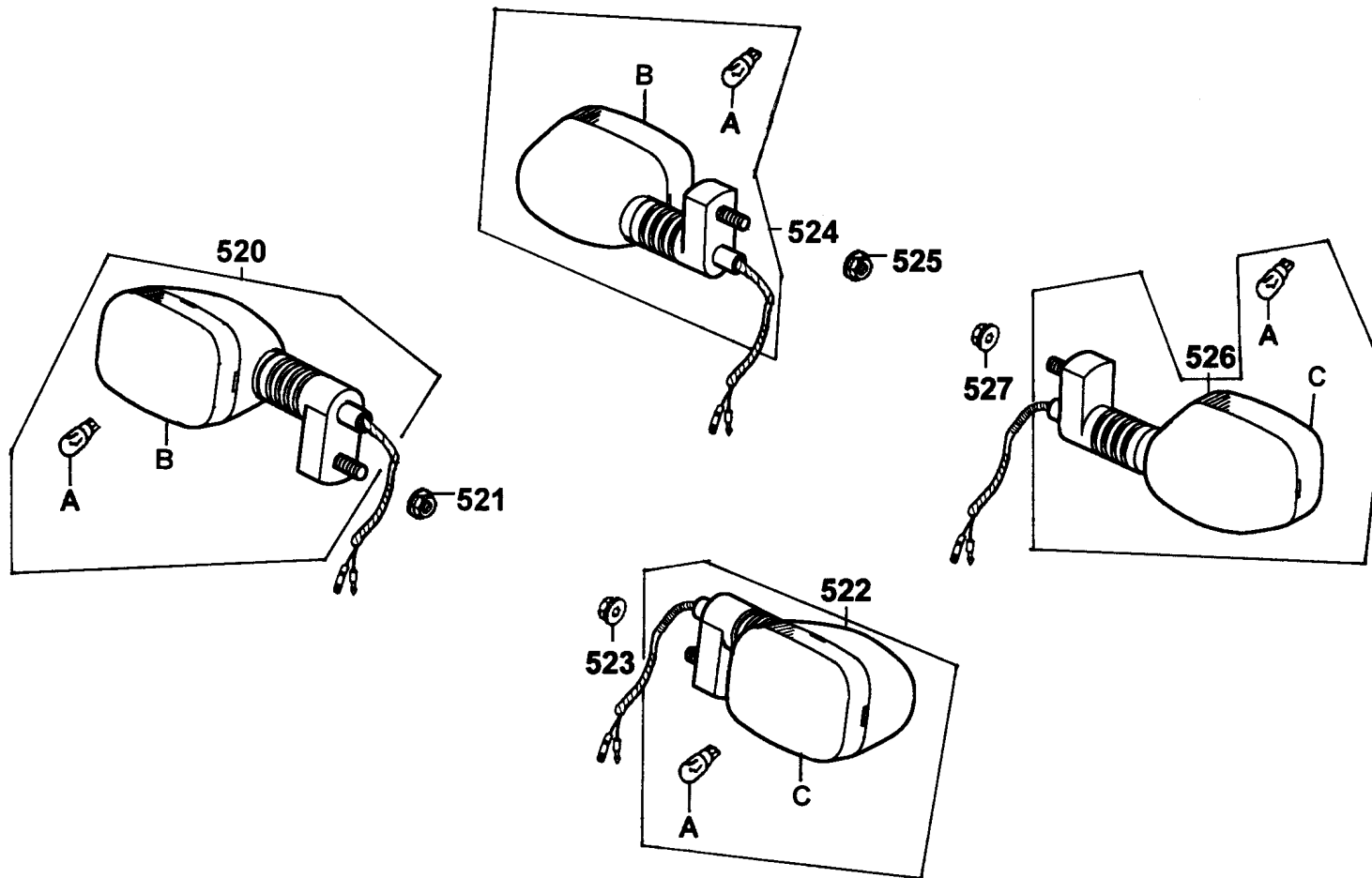

販賣記號	項目	零件號碼	版數	英文名稱	中文名稱	需要用量	參考價
Sales mark	Ref no	Part no	Ver	Description	Chinese	Regd no	Ref Price
*	520	33400-KEC8-9000	0	WINKER ASSY R FR	右前方向燈組	1	
*	521	94050-10080	0	NUT FLANGE 10MM	螺帽 10MM	1	
*	522	33450-KEC8-9000	0	WINKER ASSY L FR	左前方向燈組	1	
*	523	94050-10080	0	NUT FLANGE 10MM	螺帽 10MM	1	
*	524	33600-KEC8-9000	0	WINKER ASSY R RR	右後方向燈組	1	
*	525	94050-10080	0	NUT FLANGE 10MM	螺帽 10MM	1	
*	526	33650-KEC8-9000	0	WINKER ASSY L RR	左後方向燈組	1	
*	527	94050-10080	0	NUT FLANGE 10MM	螺帽 10MM	1	
*	A	34905-KCP-9000	0	BULB WINKER	方向燈燈泡	4	
*	B	33602-KCP-9000	0	LENS R RR WINKER	右方向燈殼	2	
*	C	33652-KCP-9000	1	LENS L RR WINKER	左方向燈殼	2	

F 21 Tail light

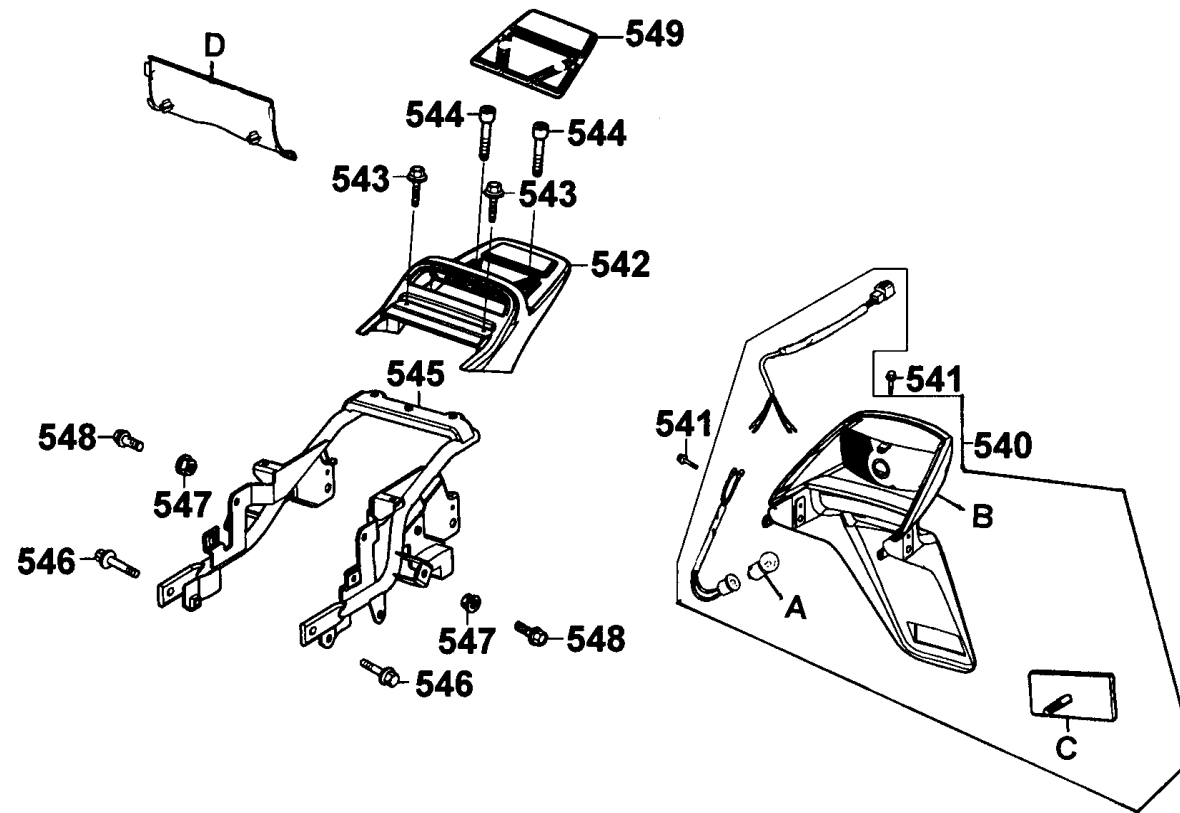

販賣記號	項目	零件號碼	版數	英文名稱	中文名稱	需要用量	參考價
Sales mark	Ref no	Part no	Ver	Description	Chinese	Regd no	Ref Price
*	540	33700-KEC8-9000	0	TAIL ASSY LIGHT	後燈組	1	
*	541	95701-06012-08	0	BOLT FLANGE 6*12	螺絲	3	
**	542	81200-KEC8-9000	0	CARRIER RR	後架	1	
*	543	93404-06020-07	0	BOLT WASHER 6*20	螺絲	2	
*	544	90105-KEC8-9000	0	BOLT WASHER 8MM	螺絲 8MM	2	
*	545	81201-KEC8-9000	0	STAY RR CARRIER	後架座	1	
*	546	95801-08030-08	0	BOLT FLANGE 8*30	螺絲	2	
*	547	94050-06080	0	NUT FLANGE 6MM	螺帽 6MM	2	
*	548	90111-147-0000	0	BOLT FLANGE 6MM	螺絲 6MM	2	
*	549	81220-KEC8-9000	0	MAT CARRIER	後架墊片	1	
*	A	34906-KCP-9000	0	BULB TAIL & STOP	後燈泡	1	
*	B	33702-KEC8-9000	0	LENS COMP TAIL LIGHT	後燈殼	1	
*	C	33741-KEC8-9000	0	REFLEX REFLECTOR	後燈反射片	1	
**	D	81210-KEC8-9000	0	LID RR CARRIER	後架小蓋	1	

F 22 Wire Harness

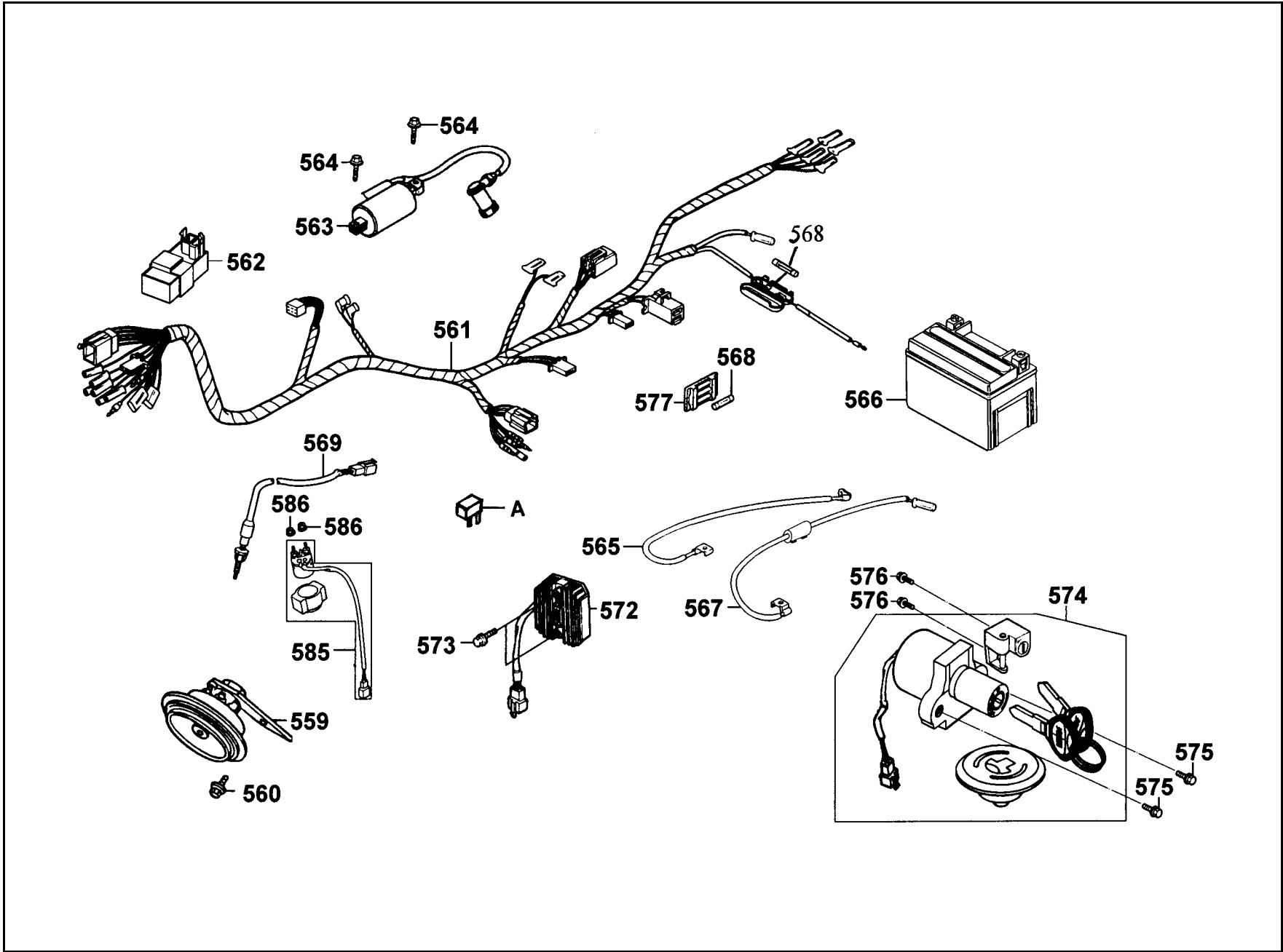

販賣記號	項目	零件號碼	版數	英文名稱	中文名稱	需要用量	參考價
Sales mark	Ref no	Part no	Ver	Description	Chinese	Regd no	Ref Price
*	559	38110-KBE-9000-M1	0	HORN COMP	喇叭	1	
*	560	95701-08012-08	0	BOLT FLANGE 8*12	螺絲 8X12	1	
*	561	32100-KEC8-E000	0	HARNESS WIRE	主電路配線	1	
*	562	30400-KEC8-E000	0	UNIT ASSY CDI	C.D.I.組	1	
*	563	3051A-KEC8-9000	0	COIL ASSY IGN	點火線圈	1	
*	564	90112-KDR-9000	0	BOLT FLANGE 5*22	螺絲 5X22	2	
*	565	32401-KEC8-9000	0	CABLE EARTH	接地線	1	
*	566	31500-GY6-9400-M1	1	BATTERY	電瓶	1	
*	566	31500-GY6-9400-M2	1	BATTERY	電瓶	1	
*	567	32402-KEC8-9000	0	CABLE RELAY BATT	電瓶繼電器配線	1	
*	568	98200-11500	0	FUSE A15	保險絲 A15	2	
*	569	35350-KE2-9400	1	REAR STOP SW	後煞車燈開關組	1	
*	572	31600-KR1-7620-M1	1	REG REC COMP	整流器	1	
*	573	95701-06014-08	0	BOLT FLANGE 6*14	螺絲 6X14	2	
*	574	35010-KEC8-E000	0	KEY SET	開關組	1	
*	575	95701-KEC8-E000	0	BOLT TOROU 8*19	螺絲 8X19	2	
*	576	95701-06045-08	0	BOLT FLANGE 6*45	螺絲 6X45	2	
*	577	38205-115-0000	0	CASE FUSE	保險絲蓋	1	
*	585	35850-KAK-9000	0	SET START MAG	起動繼電器	1	
*	586	94050-06080	0	NUT FLANGE 6MM	螺帽 6MM	2	

F 22 Wire Harness

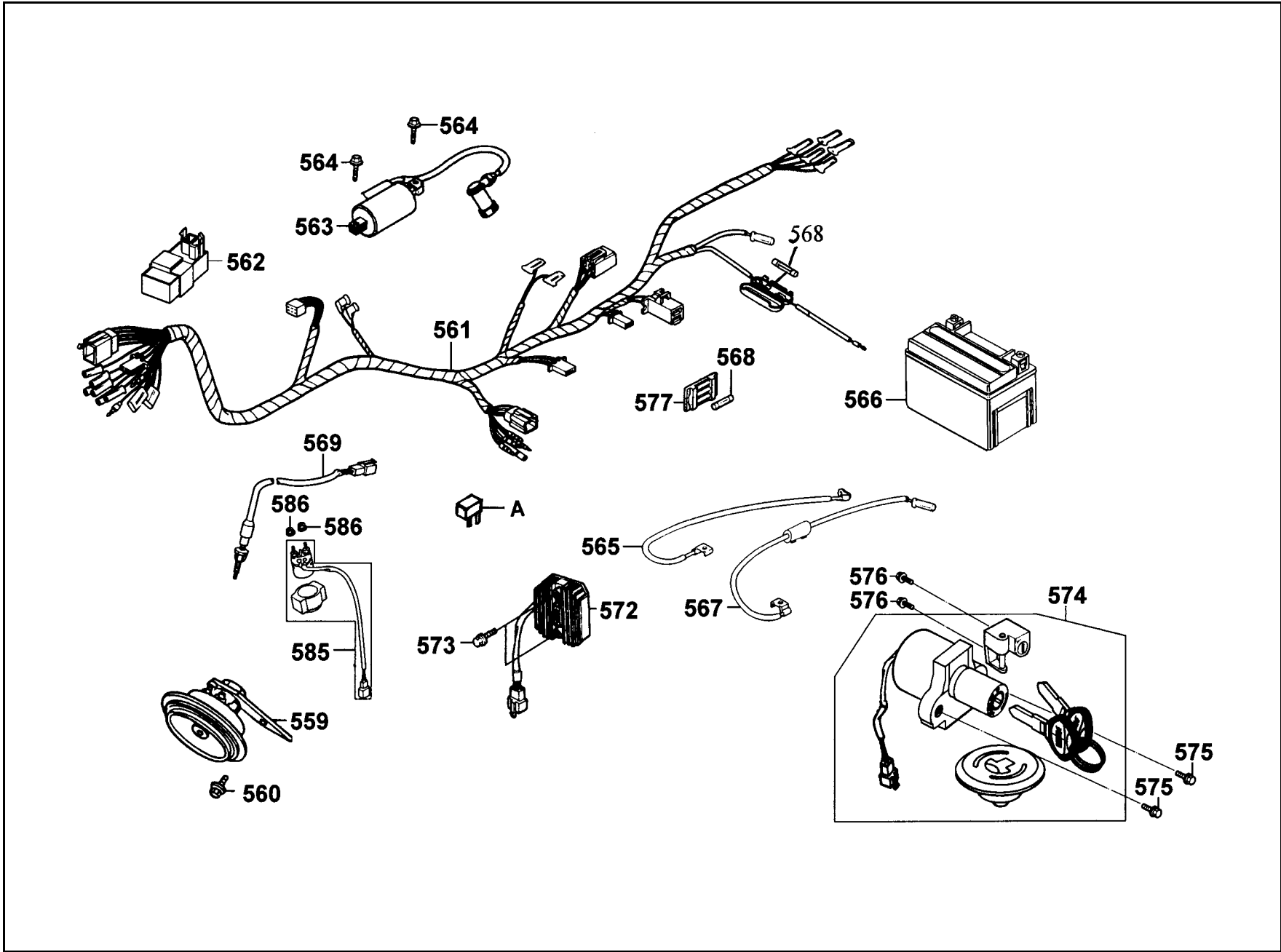

販賣記號	項目	零件號碼	版數	英文名稱	中文名稱	需要用量	參考價
Sales mark	Ref no	Part no	Ver	Description	Chinese	Regd no	Ref Price
*	A	31700-KEC8-E000	0	RECTIFIER COMP	二極體整流器	1	

F 22

F 23 Frame Body

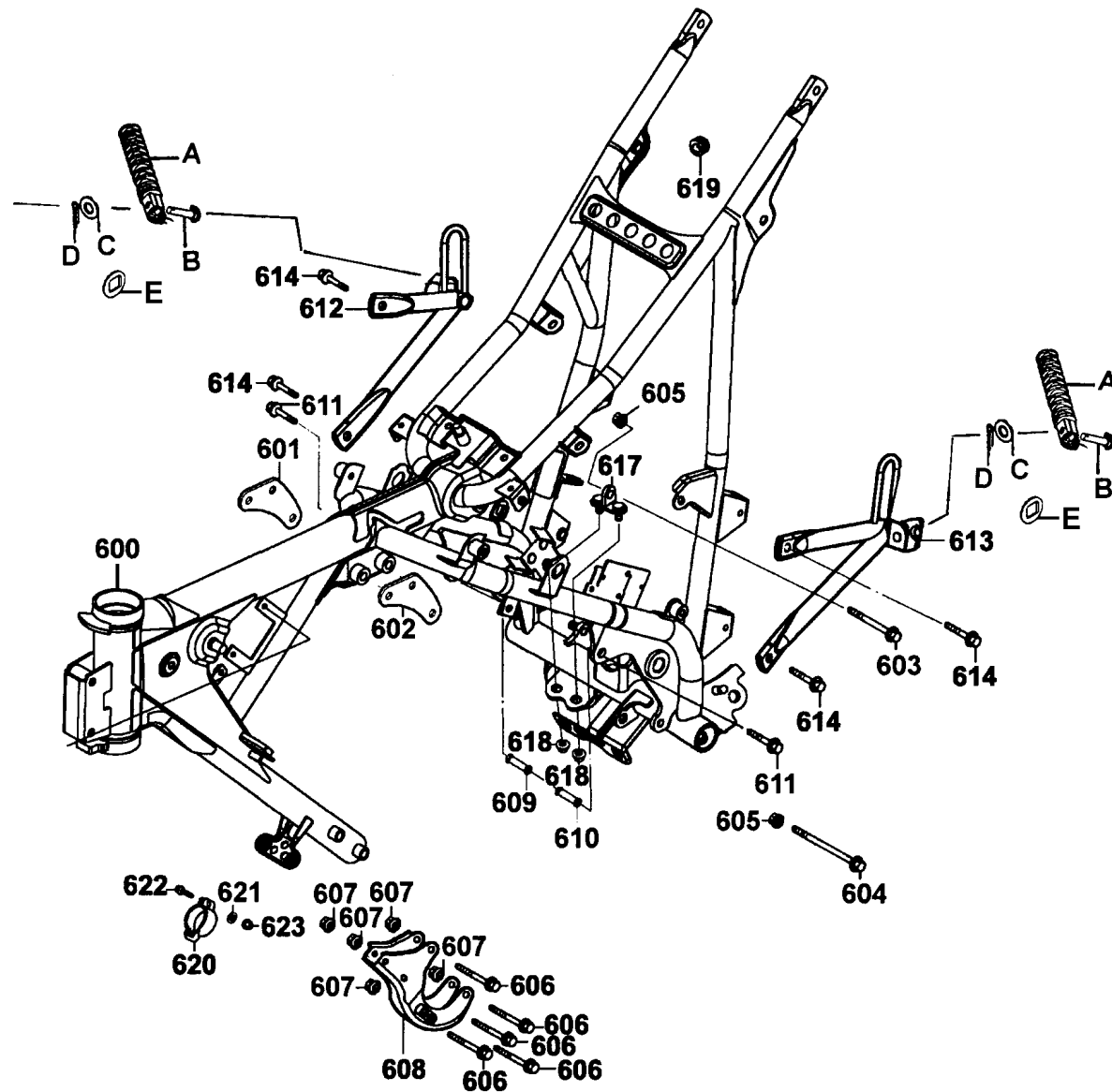

販賣記號	項目	零件號碼	版數	英文名稱	中文名稱	需要用量	參考價
Sales mark	Ref no	Part no	Ver	Description	Chinese	Regd no	Ref Price
*	600	50100-KEC8-E000	0	BODY COMP FRAME	車體	1	
*	601	50353-KEC8-9000	0	PLATE R ENG UP HANGER	引擎右上端吊板	1	
*	602	50354-KEC8-9000	0	PLATE L ENG UP HANGER	引擎左上端吊板	1	
*	603	90019-399-0110	1	BOLT FLANGE 10*113	螺絲 10X113	1	
*	604	90101-KEC8-90000	0	BOLT FLANGE 10*250	螺絲 10X250	1	
*	605	90304-KG8-0030	0	NUT U 10MM	螺帽 10MM	2	
*	606	95801-08070-00	0	BOLT FLANGE 8*70	螺絲 8X70	5	
*	607	94050-KE2-9000	0	NUT FLANGE 8MM	螺帽 8MM	5	
*	608	50355-KEC8-9000	0	PLATE FR ENG HANGER	引擎前端吊架	1	
*	609	50357-KEC8-9000	0	COLLAR ENG R	右邊引擎套筒	1	
*	610	50356-KEC8-9000	0	COLLAR ENG L	左邊引擎套筒	1	
*	611	95801-08085-00	0	BOLT FLANGE 8*85	螺絲 8X85	2	
*	612	50190-KEC8-9000	0	STEP COMP R PILLON	右踏板連桿	1	
*	613	50191-KEC8-9000	0	STEP COMP L PILLON	左踏板連桿	1	
*	614	95801-08020-00	0	BOLT FLANGE 8*20	螺絲 8X20	4	
*	617	50351-KEC8-9000	0	SLIDER HANGER BOTTOM	引擎吊架固定座	1	
*	618	94050-KE2-9000	0	NUT FLANGE 8MM	螺帽 8MM	2	
*	619	17245-107-0100	1	RUBBER AIR/C CASE MOUNT	橡皮	1	
*	620	22878-KC5-0010	0	CLAMPER CLUTCH CABLE	線夾	1	
*	621	94101-05800	0	WASHER PLAIN 5MM	華司	1	

F 23

F 23 Frame Body

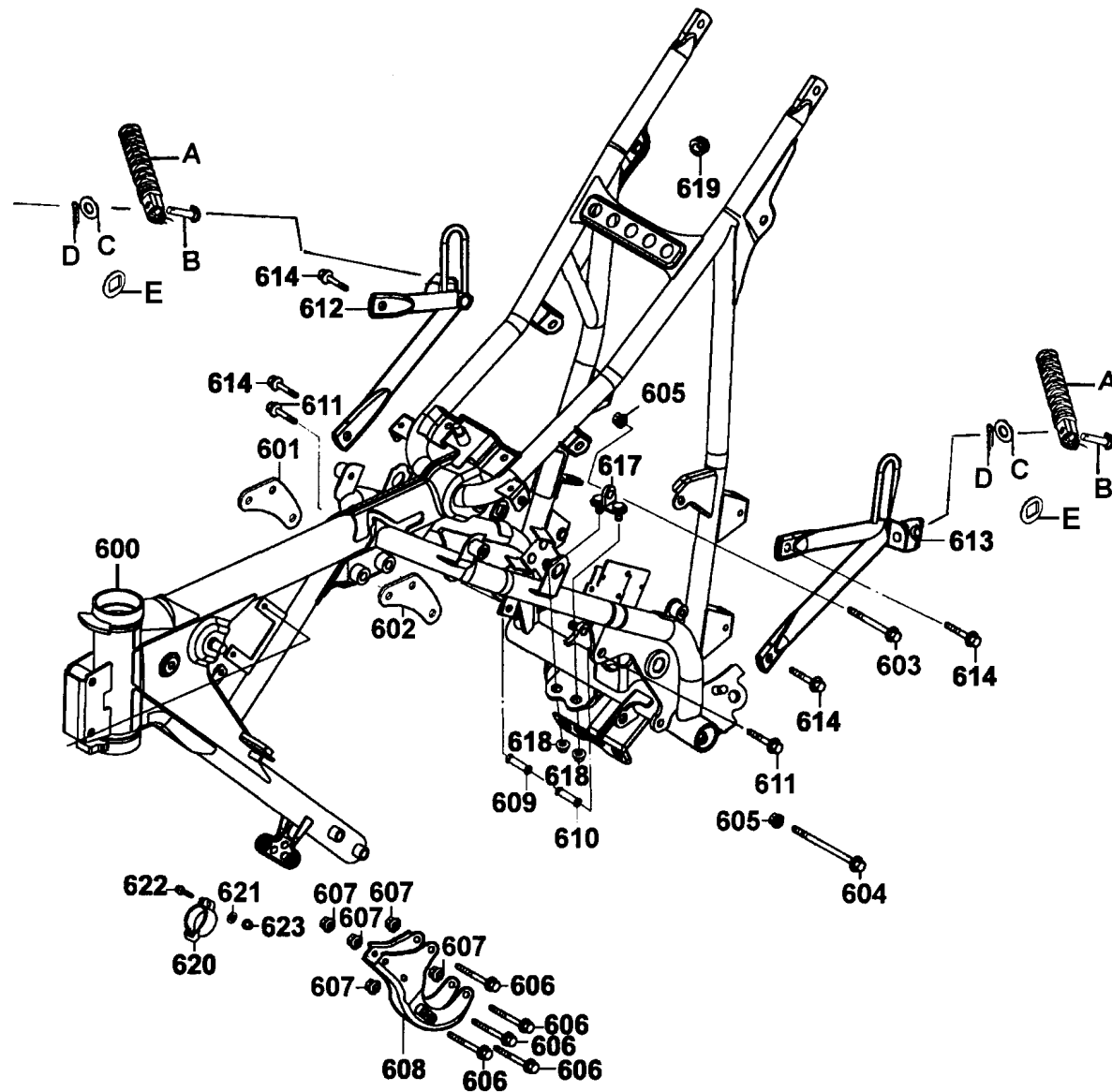

販賣記號	項目	零件號碼	版數	英文名稱	中文名稱	需要用量	參考價
Sales mark	Ref no	Part no	Ver	Description	Chinese	Regd no	Ref Price
*	622	93500-05022-0G	0	SCREW PAN 5*22	螺絲	1	
*	623	94050-05080	0	NUT FLANGE 5MM	螺帽 5MM	1	
*	A	50700-KEC8-3050	0	BAR PILLION ASSY STEP	踏板	2	
*	B	50715-KEC8-9000	0	PIN PILLION STEP	插銷	2	
*	C	94101-06000	0	WASHER PLAIN 6MM	華司	2	
*	D	94251-06400	0	PIN LOCK 6MM	銷	2	
*	E	50714-KEC8-9000	0	WASHER PILLON STEP	腳踏板華司	2	

F 23

F 24 Caution label

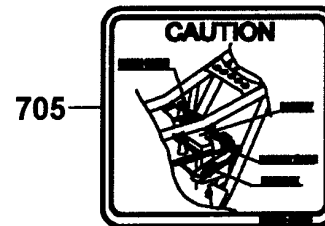
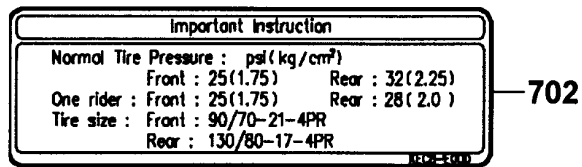
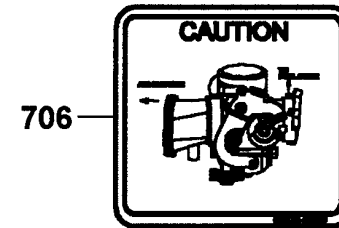
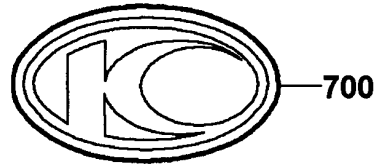

販賣記號	項目	零件號碼	版數	英文名稱	中文名稱	需要用量	參考價
Sales mark	Ref no	Part no	Ver	Description	Chinese	Regd no	Ref Price
	700	86102-KFA2-9000	0	EMB K-LOGO 20MM	標籤	1	
	701	87511-KAK-Q000	0	LABEL HELMET HOLDER	安全帽掛鉤	1	
	702	87505-KEC8-E000	0	MARK TIRE CAUTION	胎壓警示標籤	1	
	703	87224-KEC8-E000-GM	0	CAUTION ANTI TAMPERING	標籤	1	
	704	87501-KDR-E000	0	CAUTION USE GAS ONLY	標籤	1	
	705	87506-KEC8-E000	0	MARK BATTERY CAUTION	標籤	1	
	706	87507-KEC8-E000	0	MARK ACV CAUTION	標籤	1	

F 24

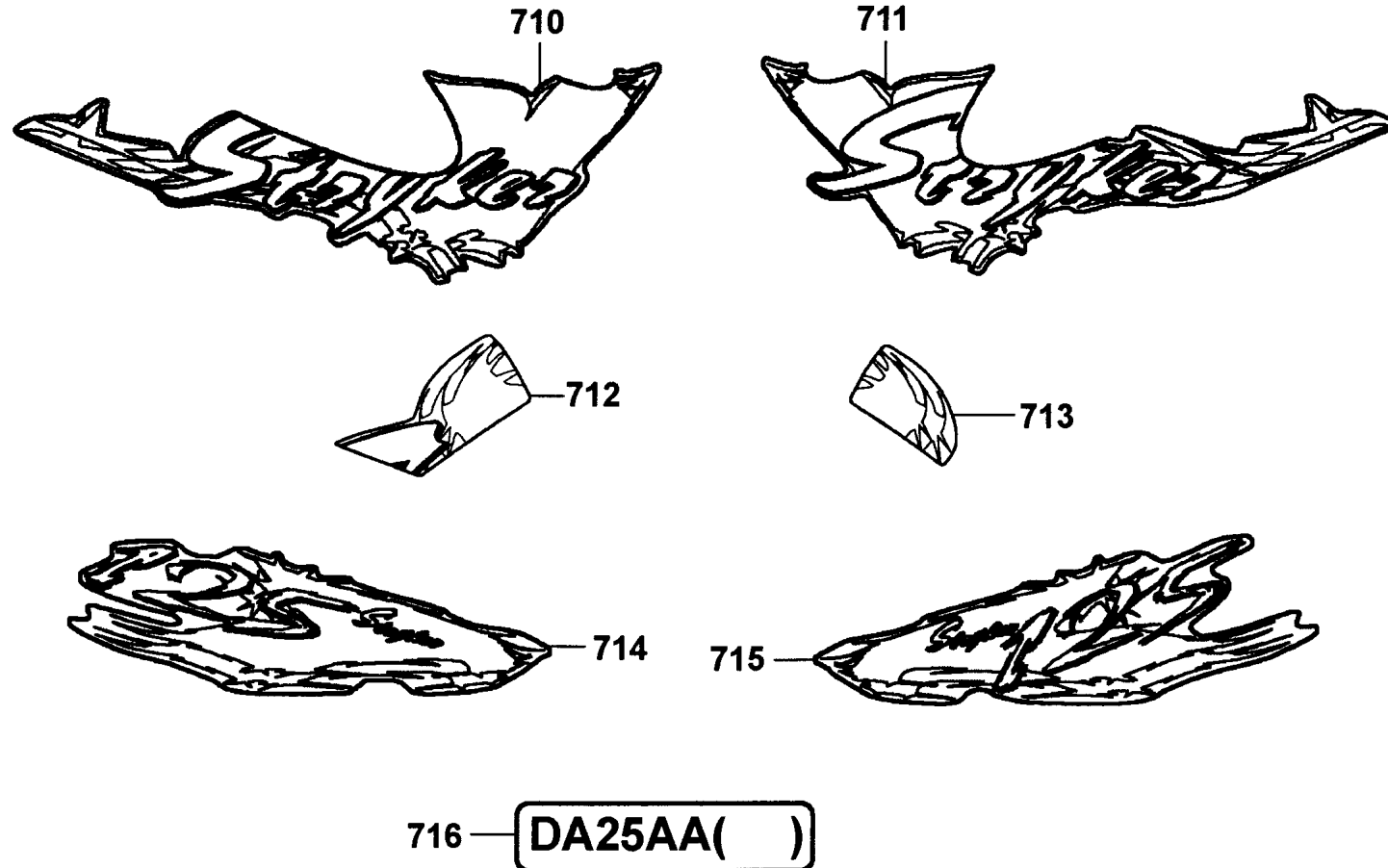

販賣記號	項目	零件號碼	版數	英文名稱	中文名稱	需要用量	參考價
Sales mark	Ref no	Part no	Ver	Description	Chinese	Regd no	Ref Price
*	710	86103-KEC8-E000-GM	0	STRIPE R COWL	右擋泥板貼紙	1	
*	711	86133-KEC8-E000-GM	0	STRIPE L COWL	左擋泥板貼紙	1	
*	712	86113-KEC8-E000-GM	0	STRIPE R B COWL	右擋泥板貼紙 B	1	
*	713	86143-KEC8-E000-GM	0	STRIPE L B COWL	左擋泥板貼紙 B	1	
*	714	86423-KEC8-E000-GM	0	STRIPE R BODY COVER	右邊蓋標誌	1	
*	715	86443-KEC8-E000-GM	0	STRIPE L BODY COVER	左邊蓋標誌	1	
	716	87503-KEC8-E000-FR	0	MARK MODEL	機種名稱標誌	1	

零 件 號 碼 索 引

PART NO. INDEX

零 件 號 碼 PART NO.	版數 VER.	頁 次 PAGE	零 件 號 碼 PART NO.	版數 VER.	頁 次 PAGE	零 件 號 碼 PART NO.	版數 VER.	頁 次 PAGE
						15136-383-0000	0	P-23
11000						15331-399-0000	0	P-23
			14000			15332-399-0000	0	P-23
11100-KEC8-9000	0	P-33				15421-107-0000	1	P-33
11108-KEC8-9000	0	P-85	14100-KEC8-9000	0	P-17	15426-107-0000	0	P-33
11191-KEC8-9000	0	P-33	14401-KEC8-9000-M1	0	P-17	15430-440-0300	0	P-25
11200-KEC8-9000	0	P-33	14402-KEC8-9000	0	P-17	15436-107-0000	1	P-23
11330-KEC8-9000	0	P-21	14431-KEC8-9000	1	P-19	15441-107-0000	0	P-25
11340-KEC8-9000	0	P-29	14451-KEC8-9000	1	P-19	15446-107-0000	0	P-23
11361-KEC8-9000	0	P-29	14452-KEC8-9000	0	P-19	15451-107-0000	0	P-23
11393-107-0210	0	P-21	14453-KEC8-9000	0	P-19	15459-107-0000	0	P-23
11395-KEC8-9000	0	P-31	14510-KEC8-9000	0	P-17	15650-KAK-9000	0	P-21
			14520-GY6-9010-M1	1	P-17	15772-292-0100	0	P-83
			14523-GY6-9000	0	P-17	15772-551-0000	1	P-75
12000			14531-KJ9-0010	0	P-17			
			14610-KEC8-9000	0	P-17			
12100-KEC8-9000	0	P-15	14711-383-0000	0	P-17	16000		
12191-KEC8-9000	0	P-15	14721-383-0000	0	P-17			
12200-KEC8-E000	0	P-15	14751-KEC8-9000	0	P-19	1610K-KEC8-E000	0	P-45
12206-KCS-6500-H1	0	P-15	14761-KEC8-9000	0	P-19	16210-KEC8-E100	0	P-15
12208-413-0030	0	P-17	14771-107-0200	2	P-17	16920-KEC8-8000	0	P-75
12211-KEC8-9000	1	P-19	14775-107-0000	1	P-17	16950-KEC8-9000	0	P-75
12251-KEC8-9000	0	P-15	14776-107-0100	1	P-17	16952-KEC8-9000	0	P-75
1231A-KEC8-9000	0	P-15	14781-107-0200	1	P-17	16955-KEC8-9000	0	P-77
12361-107-0010	0	P-33				16960-KEC8-9000	0	P-77
12391-KEC8-9000	0	P-15						
			15000					
						17000		
13000			15100-KAK-9000	0	P-23			
			15106-330-0100	0	P-23	17211-KEC8-9000	0	P-83
13000-KEC8-9000	0	P-35	15111-440-0100	0	P-23	17219-KEC8-9000	0	P-83
13011-383-6210	0	P-35	15116-107-0200	0	P-23	17226-KEC8-9000	0	P-83
13101-383-0210	0	P-35	15126-107-0020	1	P-23	17228-KEC8-9000	0	P-83
13111-440-0010	0	P-35	15131-KAK-9000	0	P-23	17229-KEC8-9000	0	P-83

零 件 號 碼 索 引

PART NO. INDEX

零 件 號 碼 PART NO.	版數 VER.	頁 次 PAGE	零 件 號 碼 PART NO.	版數 VER.	頁 次 PAGE	零 件 號 碼 PART NO.	版數 VER.	頁 次 PAGE
17236-KBF-9000	0	P-83				23531-439-0000	1	P-37
17236-KEC8-9000	0	P-83	22100-324-0010	3	P-27	23801-KAK-9000	0	P-39
17245-107-0100	1	P-111	22121-107-0110	2	P-27	23811-KR3-6000	0	P-39
17253-KEC8-9000	0	P-83	22201-KAK-9000	0	P-27			
17256-GY6-9010	3	P-15	22311-107-0000	2	P-27			
17265-KG7-0010	0	P-83	22350-107-0120	4	P-27	24000		
17266-KG7-0010	0	P-83	22361-107-0010	0	P-27			
17360-GE1-9000	2	P-85	22366-383-0010	0	P-27	24211-107-0010	0	P-43
17504-KEC8-E000	0	P-75	22810-365-0010	0	P-21	24221-355-0010	2	P-43
17505-KEC8-9000	0	P-75	22816-355-0000	1	P-21	24231-107-0100	3	P-43
17510-KEC8-E000	0	P-75	22821-355-0010	0	P-21	24241-107-0000	1	P-43
17520-KEC8-9000	0	P-77	22838-355-0010	0	P-33	24301-KAK-9000	2	P-43
1752A-KEC8-9000	0	P-75	22850-355-0010	0	P-27	24411-KAK-9000	0	P-43
17611-286-0000	0	P-75	22870-KE2-9810	0	P-49	24430-324-0000	2	P-43
17910-KEC8-9000	1	P-49	22878-KC5-0010	0	P-113	24435-KAK-9000	0	P-43
						24610-KC6-0000	2	P-43
						24621-107-7600	4	P-43
18000			23000			24631-107-0000	0	P-43
						24651-398-9400	0	P-43
18231-365-6700	1	P-87	23121-383-0000	2	P-25	24700-KEC8-9000	0	P-91
18233-383-9000	1	P-87	23211-383-0010	0	P-37			
18291-166-0030	0	P-87	23221-KAK-9000	0	P-39			
18291-216-0000	1	P-87	23426-KAK-9000	0	P-37	28000		
18291-KEC8-9000	0	P-87	23427-439-0000	0	P-37			
18292-KEC8-9000	0	P-87	23431-439-0000	0	P-37	28110-KEC8-9000	0	P-29
18293-KEC8-9000	0	P-87	23441-KAK-9000	0	P-37	28114-KEC8-9000	0	P-35
18294-KCT-9000	0	P-87	23451-KAK-9000	0	P-39	28120-GY6-9600	2	P-29
18294-KEC8-9000	0	P-87	23461-439-0000	1	P-37	28125-426-0000	0	P-29
18310-KEC8-E000	0	P-87	23471-439-0000	0	P-37	28126-323-9000	0	P-29
18318-KEC8-9000	0	P-87	23481-439-0000	0	P-37	28211-397-0100-M1	1	P-39
18320-KEC8-E000	0	P-87	23491-439-0000	1	P-37	28221-397-0200-M1	1	P-39
18321-KEC8-9000	0	P-87	23501-KAK-9000	1	P-37	28251-397-0110	0	P-39
			23511-KAK-9000	1	P-39	28253-KA2-0000	0	P-39
22000			23520-383-0010	0	P-37	28261-397-0000	2	P-39

零 件 號 碼 索 引

PART NO. INDEX

零 件 號 碼 PART NO.	版數 VER.	頁 次 PAGE	零 件 號 碼 PART NO.	版數 VER.	頁 次 PAGE	零 件 號 碼 PART NO.	版數 VER.	頁 次 PAGE
28262-397-0000	0	P-39	33000			35753-028-6010	0	P-43
28263-397-0000	0	P-39				3575A-001-0200	0	P-33
28270-397-0210	0	P-39	33100-KEC8-9000	0	P-53	35850-KAK-9000	0	P-107
2830A-KEC8-8000	0	P-89	33120-KEC8-9000	0	P-53			
			33400-KEC8-9000	0	P-103			
			33450-KEC8-9000	0	P-103	37000		
30000			33600-KEC8-9000	0	P-103			
			33602-KCP-9000	0	P-103	37200-KEC8-9000	0	P-55
30400-KEC8-E000	0	P-107	33650-KEC8-9000	0	P-103	37801-GA7-7000	1	P-75
3051A-KEC8-9000	0	P-107	33652-KCP-9000	1	P-103	37802-KEC8-9000	0	P-75
			33700-KEC8-9000	0	P-105	3780A-KEC8-9000	0	P-75
			33702-KEC8-9000	0	P-105			
31000			33741-GY6-C300	1	P-65			
			33741-KEC8-9000	0	P-105	38000		
31110-KEC8-9000-M1	0	P-31						
31110-KEC8-9000-M2	0	P-31				38110-KBE-9000-M1	0	P-107
31120-KEC8-9000-M1	0	P-31	34000			38205-115-0000	0	P-107
31120-KEC8-9000-M2	0	P-31				38301-GW0-9010	0	P-55
31200-KEC8-9000	0	P-29	34901-KAB-9000	0	P-53			
31241-KEC8-9000	0	P-29	34905-KCP-9000	0	P-103			
31500-GY6-9400-M1	1	P-107	34906-KCP-9000	0	P-105	40000		
31500-GY6-9400-M2	1	P-107	34908-KCU-9000	0	P-53			
31600-KR1-7620-M1	1	P-107				40510-KEC8-9000	0	P-95
31700-KEC8-E000	0	P-109				40520-KEC8-9000	0	P-95
			35000			40530-KEC8-9000-M1	0	P-95
			35010-KEC8-E000	0	P-107	40530-KEC8-9000-M2	0	P-95
			3515A-KEC8-9000	0	P-49	40543-KEC8-9000	0	P-95
32000			3520A-KEC8-9000	0	P-49			
32100-KEC8-E000	0	P-107	35340-GY6-9100	0	P-51	41000		
32401-KEC8-9000	0	P-107	35340-KBN-9000	0	P-51			
32402-KEC8-9000	0	P-107	35350-KE2-9400	1	P-107	41201-KEC8-9000	0	P-73
32976-107-0000	0	P-31	35357-KEC8-9000	0	P-89	41241-307-0110	0	P-73
			35370-KEC8-E000	0	P-93			

零 件 號 碼 索 引

PART NO. INDEX

零 件 號 碼 PART NO.	版數 VER.	頁 次 PAGE	零 件 號 碼 PART NO.	版數 VER.	頁 次 PAGE	零 件 號 碼 PART NO.	版數 VER.	頁 次 PAGE	
			44620-400-0000		1	P-69	46501-KEC8-9000	0	P-89
42000			44680-410-0010		0	P-69	46503-KEC8-9000	0	P-89
			44701-KAL-9000		0	P-69	46514-KEC8-9000	0	P-89
42301-KEC8-9000	0	P-73	44710-KEC8-9000-M1		0	P-69			
42311-KEC8-9000	0	P-73	44721-KAK-9000		0	P-69			
42313-KEC8-9000	0	P-73	44722-KAK-9000		0	P-69	50000		
42600-KEC8-3050	0	P-73	44800-KEC8-9000		0	P-69			
42600-KEC8-3150	0	P-73	44830-KEC8-9000		0	P-55	50100-KEC8-E000	0	P-111
42620-KEC2-9000	0	P-73					50133-KEC8-9000-H1	0	P-89
42701-KEC8-8000	0	P-73					50134-KEC8-9000-H1	0	P-91
42710-KEC8-9000-M1	0	P-73	45000				50173-KEC8-9000	0	P-83
							50174-KEC8-9000	0	P-83
			45108-ML4-0060		2	P-67	50190-KEC8-9000	0	P-111
43000			45121-KW6-9010		1	P-69	50191-KEC8-9000	0	P-111
			45126-KEC8-9000		0	P-51	50321-KG7-0000	0	P-83
43100-KG7-8310	1	P-71	45131-166-0160		0	P-67	50322-KG7-0000	0	P-83
43120-KG7-0020	0	P-71	45131-GE2-0060		1	P-67	50351-KEC8-9000	0	P-111
43141-KEC8-9000	0	P-71	45132-166-0160		0	P-67	50353-KEC8-9000	0	P-111
43215-KBE-9000	0	P-67	45133-240-0000		1	P-71	50354-KEC8-9000	0	P-111
43352-568-0030	3	P-67	45133-MA3-0060		0	P-67	50355-KEC8-9000	0	P-111
43353-461-7710-M1	0	P-67	45134-250-0000		0	P-71	50356-KEC8-9000	0	P-111
43410-KEC8-9000	0	P-71	45150-KEC8-3050		0	P-67	50357-KEC8-9000	0	P-111
43431-KEC8-9000	0	P-97	45156-KBN-9000		0	P-65	50530-KEC8-E000	0	P-93
43451-KEC8-9000	0	P-89	45200-KEC8-9000		0	P-67	50535-KEC8-E000	0	P-93
43452-KEC8-9000	0	P-89	45210-KEC8-9000		0	P-67	50548-324-7600-01	0	P-95
			45215-KCE-9000		0	P-67	50549-356-7000	0	P-95
			45216-166-0060		0	P-67	50613-KEC8-9000	0	P-81
44000			45216-KW6-9010-M1		0	P-67	50630-KEC8-9000	0	P-91
			45517-KAK-9000		0	P-51	5063A-KEC8-9000	0	P-91
44301-KW6-9010	1	P-69	45530-KAK-3060		0	P-51	50640-KEC8-9000	0	P-91
44311-KAK-9000	0	P-69					5064A-KEC8-9000	0	P-91
44601-KG7-9000	0	P-69					50700-KEC8-3050	0	P-113
4460A-KEC8-9000	0	P-69	46000				50714-KEC8-9000	0	P-113
4460B-KEC8-9000	0	P-69					50715-KEC8-9000	0	P-113

零 件 號 碼 索 引

PART NO. INDEX

零 件 號 碼 PART NO.	版數 VER.	頁 次 PAGE	零 件 號 碼 PART NO.	版數 VER.	頁 次 PAGE	零 件 號 碼 PART NO.	版數 VER.	頁 次 PAGE
			53140-KEC8-9000	0	P-49	6422A-KEC8-9000	0	P-57
			53166-KEC8-9000	0	P-49	64301-KEC8-9000	0	P-59
51000			53167-KW6-9010	0	P-49	64302-KEC8-9000	0	P-57
			53168-KW6-9010	0	P-49	64303-KAQ-9000	0	P-59
51400-KEC8-9000	0	P-65	53172-KEC8-9000	0	P-49	64303-KEC8-9000	0	P-57
51500-KEC8-9000	0	P-65	53173-KAK-9000	0	P-49	64304-KEC8-9000	0	P-57
			53173-KG7-9010	0	P-51	64305-KEC8-9000	0	P-57
			53175-KAK-9000	2	P-49			
52000			53178-KEC8-9000	0	P-49			
			53192-268-0000	5	P-49	77000		
52108-KE5-0030	0	P-95	53200-KEC8-9000	0	P-59			
52110-KEC8-9000	0	P-93	53204-KEC8-9000	0	P-57	77115-KEC8-3050-GM	0	P-79
52141-KEC8-9000	0	P-95	53205-KEC8-9000	0	P-59	77116-KEC8-3050-GM	0	P-79
52144-GE2-0050	0	P-95	53214-KEC8-9000-M1	0	P-57	77200-KEC8-9000	0	P-79
52171-KEC8-9000	0	P-93	5322A-KEC8-9000	0	P-57			
52172-KEC8-9000	0	P-93	53230-KEC8-9000	0	P-57			
52173-KEC8-9000	0	P-93	53240-KEC8-9000	0	P-57	80000		
52208-KEC8-9000	0	P-95						
52210-KEC8-9000	0	P-93				80101-KEC8-8000	0	P-101
52241-KEC8-9000	0	P-95	55000			80102-KEC8-9000	0	P-101
52243-KEC8-9000	0	P-95						
52310-KEC8-9000	0	P-93	55102-166-0010	0	P-77			
52400-KKEC8-9000	0	P-99				81000		
			61000			81200-KEC8-9000	0	P-105
53000						81201-KEC8-9000	0	P-105
			61110-KEC8-9000	0	P-63	81210-KEC8-9000	0	P-105
53100-KEC8-9000	0	P-57				81220-KEC8-9000	0	P-105
53102-KEC8-9000	0	P-59						
53131-439-0000	0	P-59	64000					
53132-439-0000	0	P-59				83000		
53133-236-0000	0	P-59	64110-KEC8-9000	0	P-57			
53134-283-0010	0	P-59	64206-KBN-9000	0	P-59	83500-KEC8-9000	0	P-81
5313A-KEC8-9000	0	P-61	64206-MJ0-0010	0	P-61	83510-KEC8-3050-GM	0	P-81

零 件 號 碼 索 引

PART NO. INDEX

零 件 號 碼 PART NO.	版數 VER.	頁 次 PAGE	零 件 號 碼 PART NO.	版數 VER.	頁 次 PAGE	零 件 號 碼 PART NO.	版數 VER.	頁 次 PAGE
83550-KEC8-9000	0	P-59				90111-KEC8-9000	0	P-79
83550-KEC8-9000	0	P-79	88110-KEC8-E000	0	P-51	90112-KDR-9000	0	P-107
83550-KEC8-9000	0	P-81	88120-KEC8-E000	0	P-51	90112-KEC8-9000	0	P-81
83551-KAK-9000	0	P-81				90113-422-0000	2	P-49
83551-KEC8-9000	0	P-59				90113-KEC8-8000	0	P-49
83551-KEC8-9000	0	P-79	89000			90121-KEC8-9000	0	P-93
83551-KEC8-9000	0	P-81				90122-KEC8-9000	0	P-67
83600-KEC8-9000	0	P-81	89010-KN7-C000	0	P-81	90128-KEC8-9000	0	P-73
83610-KEC8-3050-GM	0	P-81	8910A-KEC8-9000	0	P-81	90131-KBE-9000	0	P-89
						90131-KBE-9000	0	P-91
						90145-MS9-6120-M1	0	P-51
86000			90000			90206-250-0010	0	P-19
						90231-200-0110	0	P-23
86102-KFA2-9000	0	P-115	90001-GHB-6610	0	P-17	90301-473-0040	0	P-69
86103-KEC8-E000-GM	0	P-117	90005-KW1-9010	0	P-19	90301-634-6700	0	P-65
86113-KEC8-E000-GM	0	P-117	90012-415-0010	0	P-19	90302-GY6-9010	0	P-75
86133-KEC8-E000-GM	0	P-117	90019-399-0110	1	P-111	90302-GY6-9010	0	P-75
86143-KEC8-E000-GM	0	P-117	90023-KG7-0010	0	P-29	90302-GY6-9010	0	P-75
86423-KEC8-E000-GM	0	P-117	90031-KBE-9000	0	P-33	90302-GY6-9010	0	P-81
86443-KEC8-E000-GM	0	P-117	90036-GY6-9500	0	P-33	90302-GY6-9010	0	P-81
			90081-355-0010	0	P-33	90302-GY6-9010	0	P-95
			90084-KAK-9000	0	P-29	90302-GY6-9010	0	P-101
87000			90087-428-C000	0	P-31	90302-GY6-9400	0	P-75
			90101-440-0000	0	P-23	90302-KEC8-9000	0	P-59
87224-KEC8-E000-GM	0	P-115	90101-KEC8-90000	0	P-111	90302-KEC8-9000	0	P-79
87501-KDR-E000	0	P-115	90103-KEC8-9000	0	P-75	90304-GE8-0030	0	P-93
87503-KEC8-E000-FR	0	P-117	90105-KEC8-9000	0	P-105	90304-KAK-9000	1	P-57
87505-KEC8-E000	0	P-115	90106-KFC2-9000	0	P-59	90304-KG8-0030	0	P-111
87506-KEC8-E000	0	P-115	90108-KEC8-E000	0	P-93	90305-GE8-0030	0	P-93
87507-KEC8-E000	0	P-115	90110-GW0-0010	1	P-79	90305-KW6-9120-M1	0	P-73
87511-KAK-Q000	0	P-115	90110-KBE-9000	0	P-87	90306-GW0-9020-M1	0	P-69
			90110-KEB7-9000	0	P-57	90306-KF0-0040	0	P-93
			90110-KEB7-9000	0	P-95	90321-315-6710	0	P-49
88000			90111-147-0000	0	P-105	90321-KN7-9110	0	P-59

零 件 號 碼 索 引

PART NO. INDEX

零 件 號 碼 PART NO.	版數 VER.	頁 次 PAGE	零 件 號 碼 PART NO.	版數 VER.	頁 次 PAGE	零 件 號 碼 PART NO.	版數 VER.	頁 次 PAGE
90451-001-0000	2	P-43	91201-030-0260	1	P-39	93500-05022-0G	0	P-113
90451-001-0000	2	P-43	91204-259-0060	0	P-21	93500-05025-OH	0	P-49
90451-107-0000	1	P-37	91206-286-0140	0	P-33	93600-04012-1G	0	P-23
90451-365-0010	0	P-37	91252-030-0000	0	P-69	93700-05012-0H	0	P-23
90452-107-0010	0	P-37	91258-410-0000-M2	0	P-69	93700-05016-0A	0	P-55
90453-107-0020	0	P-37	91301-027-0000	2	P-21	93891-05012-07	0	P-53
90453-235-0010	0	P-39	91301-200-0010	0	P-15	93891-05012-08	0	P-83
90454-107-0010	0	P-39	91302-200-0010	0	P-15	93891-05016-0H	0	P-83
90455-107-0010	0	P-37	91302-567-0030	0	P-31	93891-06012-07	0	P-93
90459-107-0000	0	P-41	91303-107-0000	1	P-33	93893-04012-18	0	P-51
90461-107-0010	0	P-27	91303-377-0010	0	P-29	93893-25280	0	P-53
90462-107-0010	0	P-39	91304-107-0010	0	P-23	93903-25380	0	P-83
90465-MC4-0010	0	P-17	91306-105-6910	0	P-17	93903-34380	0	P-57
90474-147-0010	0	P-29	91307-035-0010	0	P-21	93903-34380	0	P-59
90503-051-8700	0	P-57				93903-34380	0	P-81
90521-GY6-9500	0	P-33				93903-34480	0	P-55
90545-300-0000	0	P-51	92000			93903-35380	0	P-57
90549-121-0000	0	P-71						
90605-200-0010	0	P-37	92000-05020-0H	0	P-23			
90652-GY6-9000	2	P-83	92000-06010-0H	0	P-39	94000		
90664-216-9000	0	P-73	92000-06020-0H	0	P-43			
90667-KEC8-9000	0	P-65	92000-06025-0H	0	P-43	94001-05070-0S	0	P-49
90668-KEC8-9000	0	P-65	92201-05025-0H	0	P-29	94001-06000-0S	0	P-89
90677-GR1-0030	1	P-57	92201-06030-0A	0	P-89	94001-06080-0S	0	P-87
90677-GR1-0030	1	P-101	92700-06035-3E	0	P-15	94001-08080-0S	0	P-97
90701-GY6-9600	0	P-29	92811-KAK-9000	0	P-95	94001-10080-0S	0	P-59
90757-439-9310	0	P-73	92812-KCD-9000	1	P-95	94002-10080-0S	0	P-93
			92912-06018-0E	0	P-69	94031-10080	0	P-73
						94050-05080	0	P-113
91000						94050-06020-02	0	P-51
			93000			94050-06080	0	P-49
						94050-06080	0	P-55
91001-KEC8-9000	0	P-35				94050-06080	0	P-87
91101-179-7110-M1	0	P-29	93404-06020-07	0	P-105			
91104-KEC8-9000-M1	0	P-35	93500-05016-0H	0	P-29	94050-06080	0	P-105

零 件 號 碼 索 引

PART NO. INDEX

零 件 號 碼 PART NO.	版數 VER.	頁 次 PAGE	零 件 號 碼 PART NO.	版數 VER.	頁 次 PAGE	零 件 號 碼 PART NO.	版數 VER.	頁 次 PAGE
94050-06080	0	P-107	94510-14000	0	P-43	95701-KEC8-E000	0	P-107
94050-08080	0	P-17	94510-16000	0	P-41	95799-06025-07	0	P-95
94050-08080	0	P-75	94510-20000	0	P-27	95801-08020-00	0	P-111
94050-10080	0	P-99	94510-20000	0	P-39	95801-08030-08	0	P-105
94050-10080	0	P-103	94524-47000	0	P-73	95801-08035-08	0	P-59
94050-10080	0	P-103	94601-15000	0	P-35	95801-08040-00	0	P-57
94050-10080	0	P-103				95801-08040-00	0	P-89
94050-10080	0	P-103				95801-08040-00	0	P-93
94050-KE2-9000	0	P-111	95000			95801-08040-02	0	P-59
94050-KE2-9000	0	P-111				95801-08045-07	0	P-57
94101-05800	0	P-113	95002-02120	0	P-85	95801-08070-00	0	P-111
94101-06000	0	P-87	95002-50000	0	P-77	95801-08085-00	0	P-111
94101-06000	0	P-113	95005-KG7-9000	1	P-85	95801-10040-08	0	P-99
94101-08800	0	P-89	9500B-KEC8-9000	0	P-15	95801-10075-08	0	P-93
94101-08800	0	P-91	9500C-KEC8-9000	0	P-75	95801-10075-08	0	P-99
94101-08800	0	P-95	95014-73100	0	P-89	95801-12080-08	0	P-93
94101-10800	0	P-93	95014-75110	0	P-27			
94101-12800	0	P-75	95015-32001	0	P-89			
94103-06700	0	P-55	95015-42000	0	P-89	96000		
94111-10800	0	P-95	95015-KEC8-9000	0	P-89			
94201-20120	0	P-89	95015-KEC8-9000	0	P-91	96001-06012-08	0	P-17
94201-20150	0	P-21	95701-06012-08	0	P-83	96001-06012-08	0	P-29
94201-20150	0	P-93	95701-06012-08	0	P-105	96001-06016-02	0	P-87
94201-20150	0	P-97	95701-06014-08	0	P-65	96001-06016-08	0	P-15
94251-06400	0	P-113	95701-06014-08	0	P-107	96001-06016-08	0	P-19
94251-08000	0	P-23	95701-06020-08	0	P-59	96001-06016-08	0	P-29
94251-08400	0	P-89	95701-06020-08	0	P-79	96001-06020-02	0	P-49
94251-08400	0	P-91	95701-06022-08	0	P-27	96001-06020-02	0	P-51
94301-08140	0	P-21	95701-06022-08	0	P-71	96001-06028-08	0	P-29
94301-10160	0	P-15	95701-06028-08	0	P-15	96001-06028-08	0	P-31
94301-10160	0	P-29	95701-06045-08	0	P-107	96001-06040-08	0	P-21
94301-10160	0	P-33	95701-08012-08	0	P-87	96001-06040-08	0	P-33
94401-25140-M1	0	P-35	95701-08012-08	0	P-107	96001-06045-08	0	P-31
94510-12000	0	P-43	95701-08035-08	0	P-89	96001-06050-02	0	P-21

