

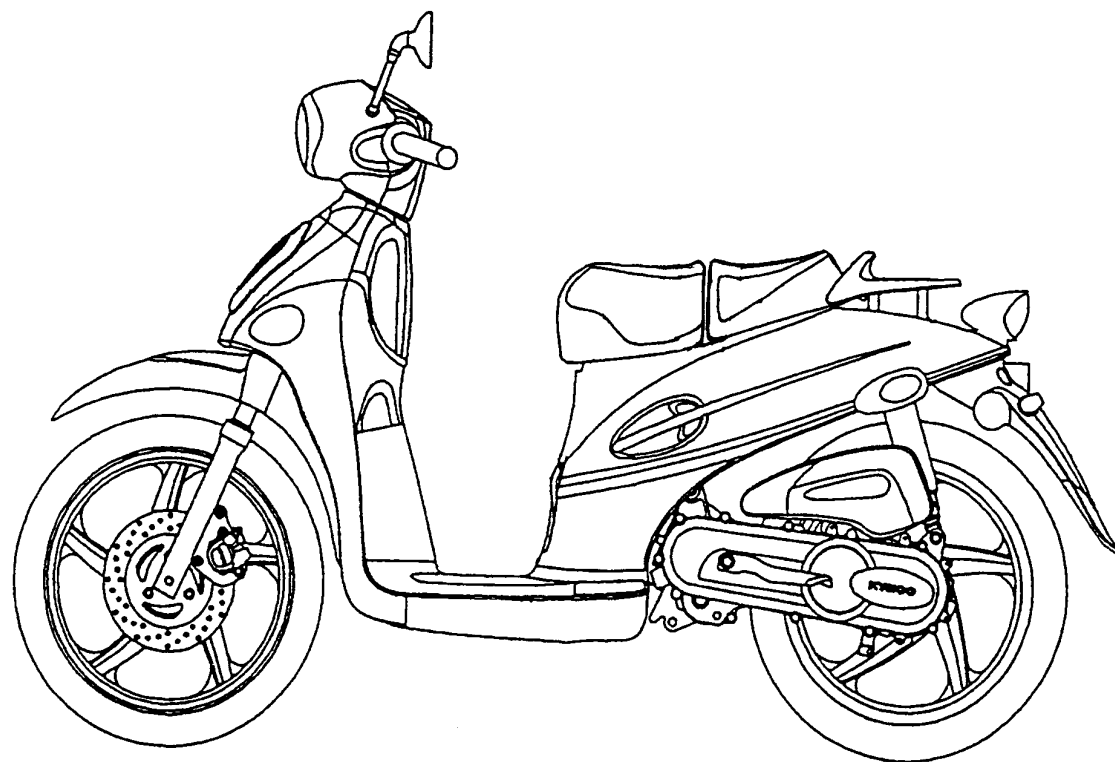

people

零件型錄
PARTS CATALOGUE

BA10AG(FL) : Jun /23 /'04 制訂



光陽機車

KYMCO

光陽機車

KYMCO

光陽機車

KYMCO

前 言

- 本零件目錄適用於 BA10AG(FL) 機種，訂購零件時，請參照本冊。
- 本冊之配色表僅供參考，若與實車不符之處，以實車為準。
- 販賣記號(Sales mark)：
 - 1、註明 ★★ 記號，表示訂購該零件時，請參照機車相片及配色表，並請在基本零件號碼最後加上色碼。
- 本冊付梓印刷倉促，倘有錯誤或遺漏之處，敬請不吝賜教指正。

ABOUT THIS PARTS LIST

- This parts list is compiled all service parts for model BA10AG(FL)。
- Any difference between color chart and motorcycle will be revised according to motorcycle。
- The sales mark：
 - 1、marking "★★" must add color code in the end before ordering parts。
- When modification or additions to this parts list are made a revised edition at an appropriate time。

目 次

●前言	1
●BA10AG(FL) 配色表.....	5
●引擎分組圖	7
●車架分組圖	9
●引擎零件號碼表.....	13
●車架零件號碼表.....	43
●零件號碼索引	105

CONTENTS

●ABOUT THIS PARTS LIST.....	1
●COLOR CHART OF BA10AG(FL).....	5
●CONTENTS-ENGINE GROUP	7
●CONTENTS-FRAME GROUP.....	9
●ENGINE PARTS LIST	13
●FRAME PARTS LIST.....	43
●PART NO. INDEX.....	105

CONTENTS-ENGINE GROUP

E10 Crankshaft●Piston -37-

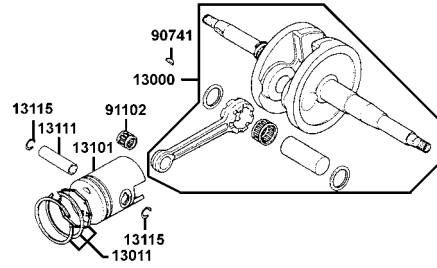

E11 Carburetor -39-

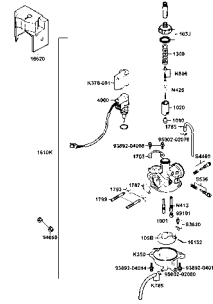

CONTENTS-FRAME GROUP

F19 Tail Light

-91-

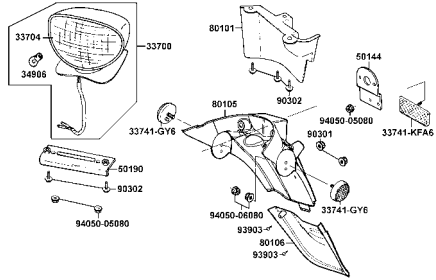

F20 Wire Harness

-93-

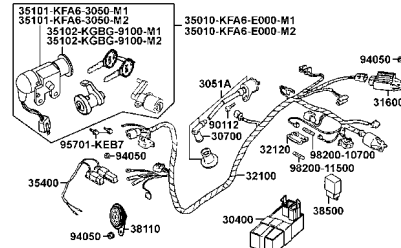

F21 Frame Body

-95-

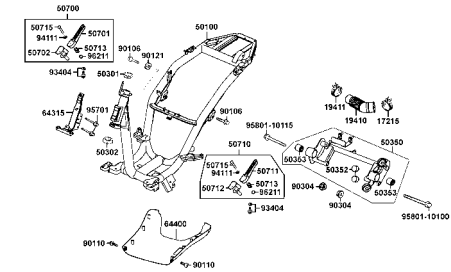

F22 Air Cleaner Two

-99-

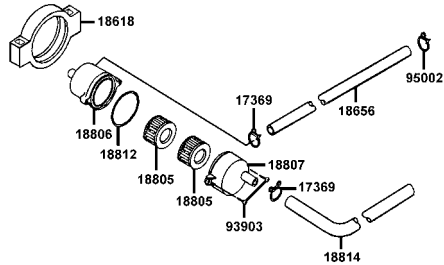

F23 Separated Pats Of Fr Fork

-101-

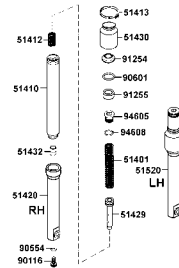

F24 Caution Label

-103-

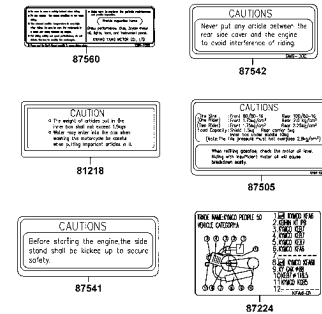

F25 Emblem Stripe

-105-

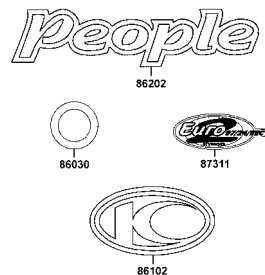

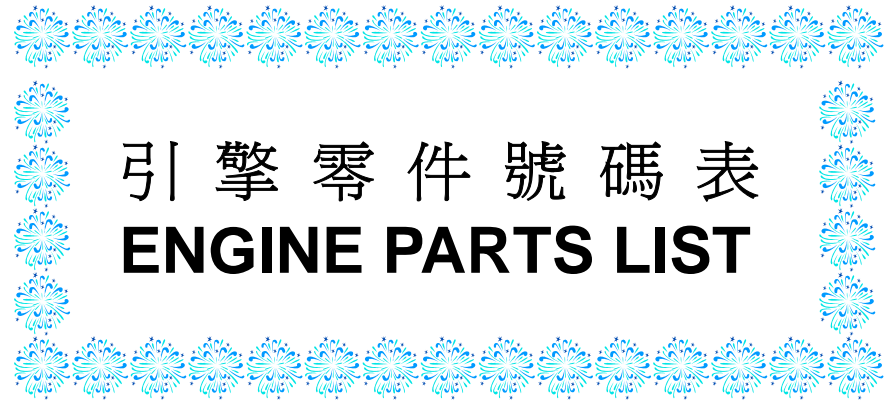

引擎零件號碼表
ENGINE PARTS LIST

E 1 Fan Cover●Shroud

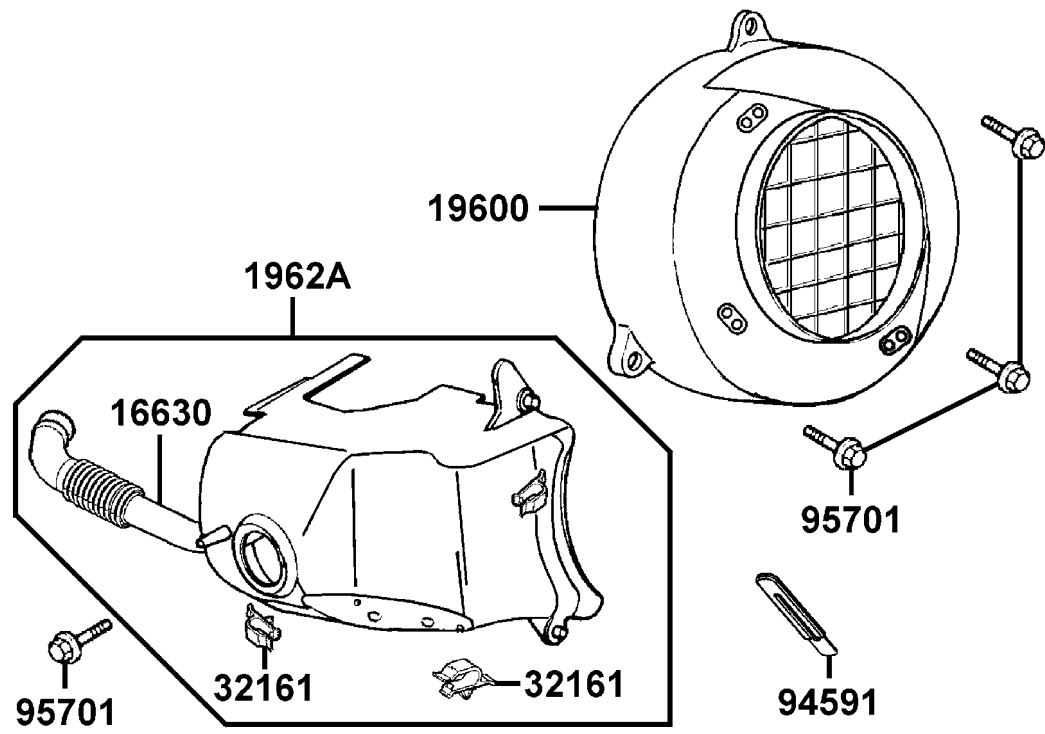

E 1

販賣記號 Sales mark	項目 Ref no	零件號碼 Part no	版數 Ver	英 文 名 稱 Description	中 文 名 稱 Chinese	需要用量 Regd no	參考價 Ref Price
		16630-KEB7-E000	0	DUCT HEAT TRANSFER	導管	1	
		19600-KEB7-9000	0	COVER COMP FAN	冷卻風扇蓋	1	
		1962A-KEB7-E000	0	CLIP SET SHROUD	引擎罩蓋	1	
		32161-393-0040	0	CLIP HARNESS WIRE	主配線夾	2	
		94591-KBF-900	2	CLIP 2*70	環夾 2*70	1	
		95701-06025-08	0	BOLT FLANGE 6*25	螺絲 6*25	4	

E 2 Cylinder●Cylinder Head

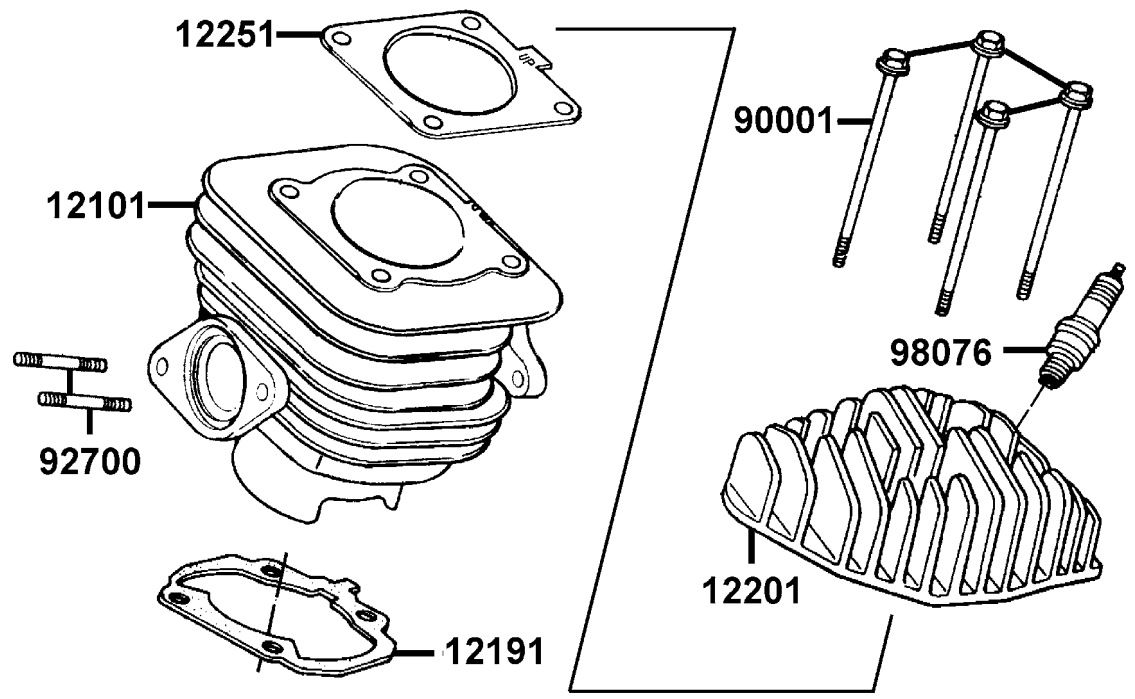

販賣記號 Sales mark	項目 Ref no	零件號碼 Part no	版數 Ver	英 文 名 稱 Description	中 文 名 稱 Chinese	需要用量 Regd no	參考價 Ref Price
		12101-KFA6-E100	0	CYLINDER	汽缸	1	
		12191-KEB7-9000	0	GASKET CYLINDER A	汽缸墊片 A	1	
		12201-KFA6-E100	0	HEAD CYLINDER	汽缸頭	1	
		12251-KEB7-9000	0	GASKET CYLINDER HEAD	汽缸頭墊片	1	
		90001-GAK-9010	0	BOLT FLANGE 7*100	特殊螺絲 7*100	4	
		92700-06028-1B	0	BOLT STUD II 6*28	雙頭螺絲 6*28	2	
		98076-5871G-00	0	SPARK PLUG (BR8HSA)	火星塞	1	

E 3 Generator

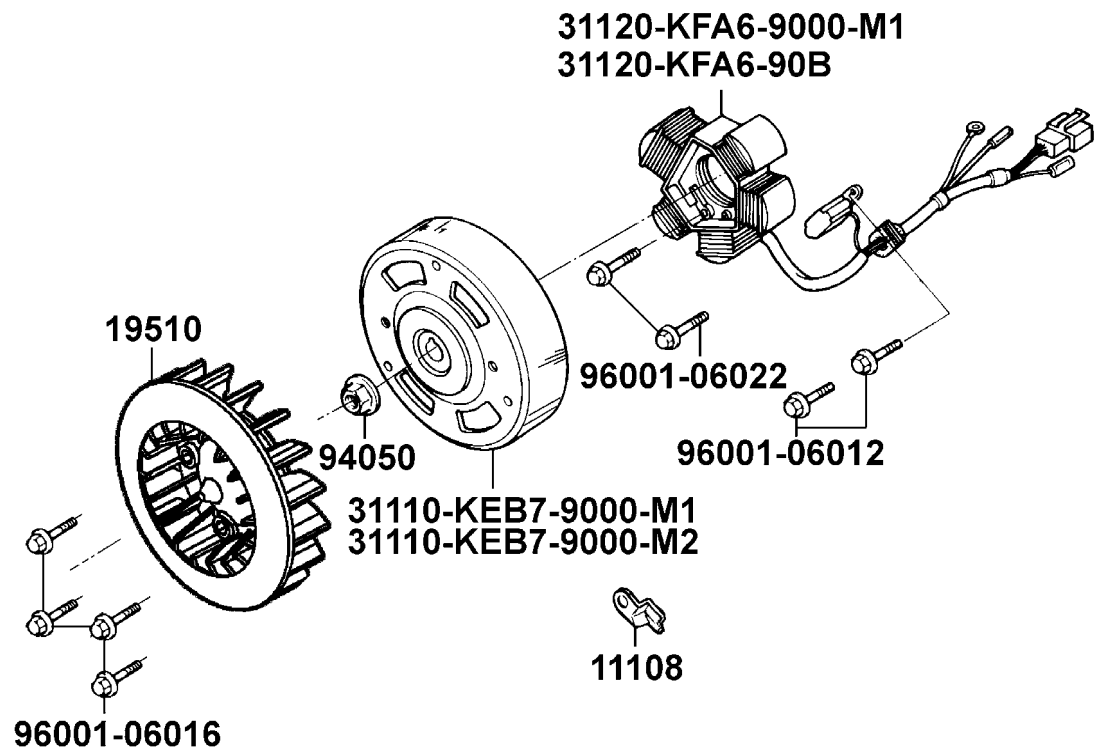

販賣記號	項目	零件號碼	版數	英文名稱	中文名稱	需要用量	參考價
Sales mark	Ref no	Part no	Ver	Description	Chinese	Regd no	Ref Price
		11108-KEB7-9000	0	HOLDER STATOR WIRE	起動馬達接地線	1	
		19510-GW2-9010	2	FAN COMP COOLING	冷卻風扇	1	
		31110-KEB7-9000-M1	2	FLYWHEEL COMP	飛輪	1	
		31110-KEB7-9000-M2	1	FLYWHEEL COMP	飛輪	1	
		31120-KFA6-9000-M1	2	STATOR COMP	轉子線圈	1	
		31120-KFA6-90B	2	STATOR COMP	轉子線圈	1	
		94050-10080	0	NUT FLANGE 10MM	螺帽 10MM	1	
		96001-06012-08	0	BOLT FLANGE SH 6*12	螺絲 6*12	2	
		96001-06016-08	0	BOLT FLANGE SH 6*16	凸緣螺絲 6*16	4	
		96001-06022-08	0	BOLT FLANGE SH 6*22	螺絲 6*22	2	

E 4 Starting Motor

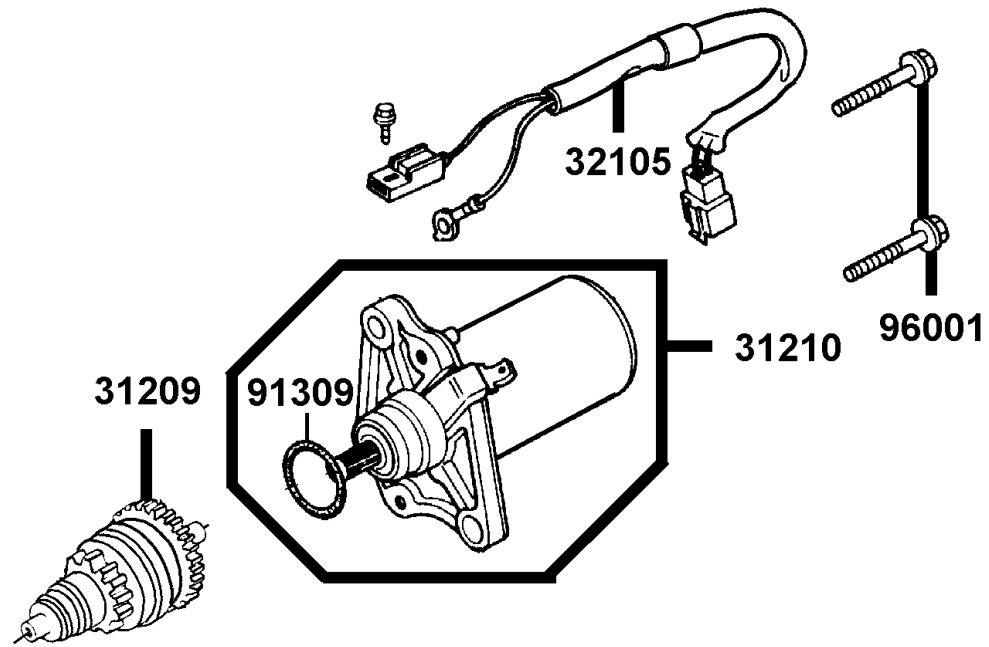

販賣記號	項目	零件號碼	版數	英 文 名 稱	中 文 名 稱	需要用量	參考價
Sales mark	Ref no	Part no	Ver	Description	Chinese	Regd no	Ref Price
		31209-GAK-9010	3	PINION ASSY STARTER	起動齒輪組	1	
		31210-GAK-9000-M3	1	MOTOR UNIT START	起動馬達組	1	
		32105-KFA6-9000	0	SUB HARNESS	副配線	1	
		91309-GAK-9010	0	O RING	O環	1	
		96001-06025-08	0	BOLT FLANGE SH 6*25	螺絲 6*25	2	

E 5 Left Side Cover

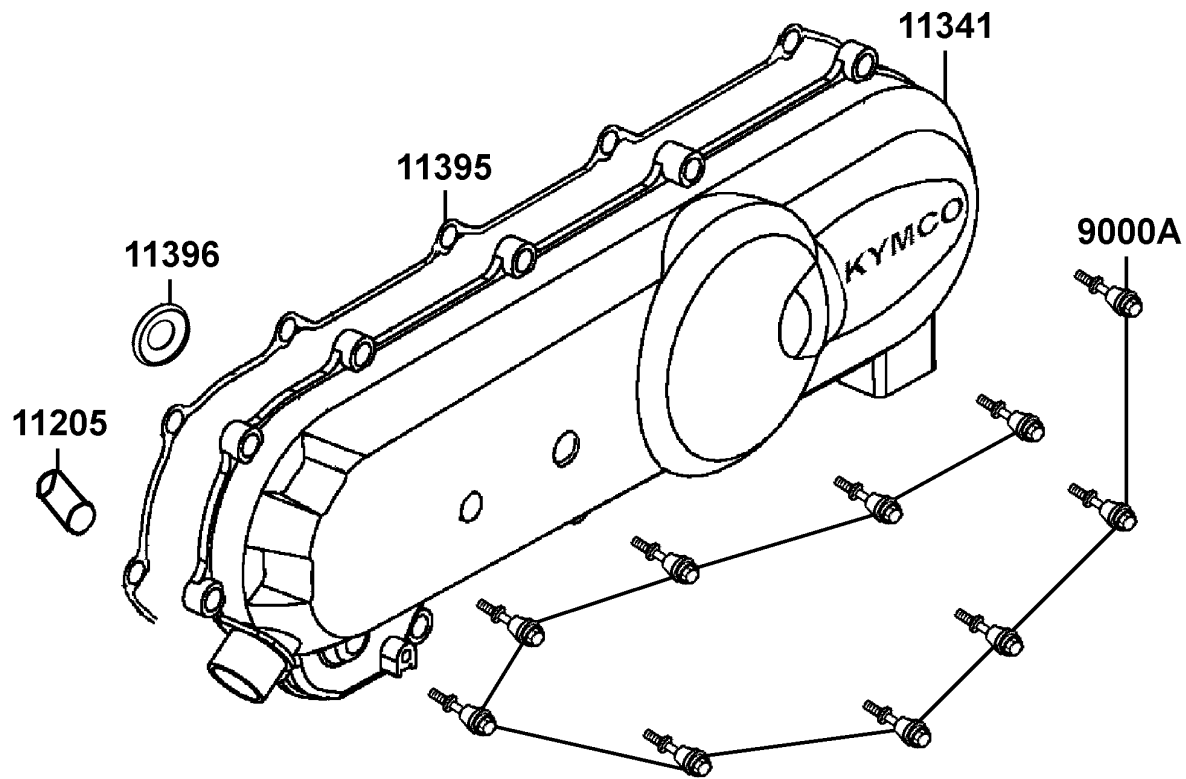

販賣記號	項目	零件號碼	版數	英 文 名 稱	中 文 名 稱	需要用量	參考價
Sales mark	Ref no	Part no	Ver	Description	Chinese	Regd no	Ref Price
		11205-GAH-0040-H1	0	BUSH 8*12*8	襯套 8*12*8	1	
**		11341-KFA6-900	0	COVER L SIDE	左曲軸箱蓋	1	
		11395-KFA6-9000	0	GASKET L COVER	左曲軸箱蓋墊片	1	
		11396-KFA6-9000	0	GASKET L COVER	左曲軸箱蓋墊片	1	
		9000A-KDT-9000	0	BOLT ASSY SPECIAL 6*28	特殊螺絲 6*28	10	

E 6 Drive Pulley

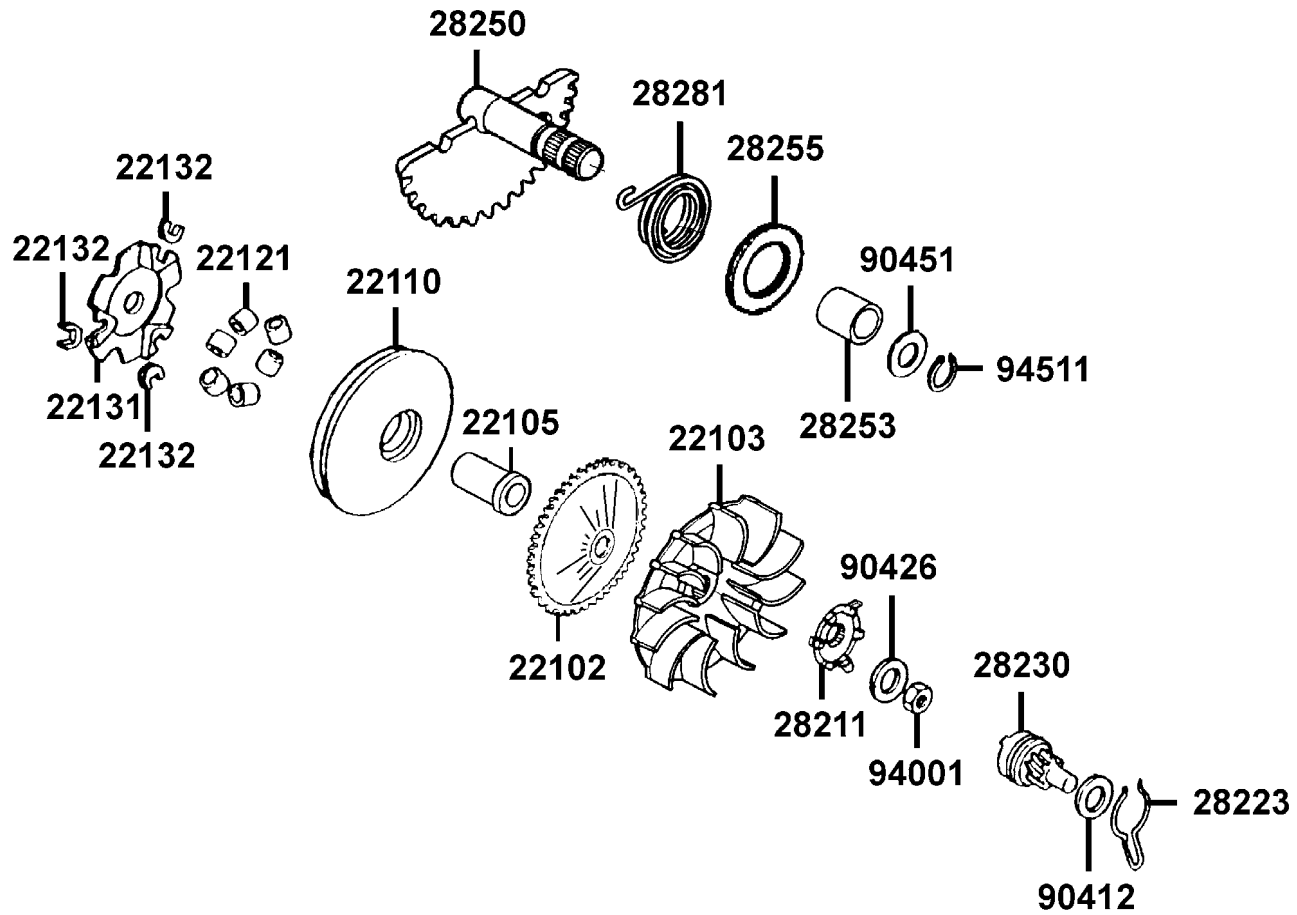

販賣記號	項目	零件號碼	版數	英 文 名 稱	中 文 名 稱	需要用量	參考價
Sales mark	Ref no	Part no	Ver	Description	Chinese	Regd no	Ref Price
		22102-KEB7-9000	0	FACE DRIVE	驅動皮帶扇葉盤	1	
		22103-KEB7-9000	0	FAN CVT COOLING	冷卻風扇	1	
		22105-KFA5-8000	0	BOSS DRIVE FACE	滑動式驅動盤襯套	1	
		22110-KFA1-2200	0	FACE COMP MOVABLE DRIVE	滑動式驅動盤	1	
		22121-GW0-9010	2	ROLLER COMP WEIGHT 8.5 gr	配重滾子	6	
		22131-GAH-7810	0	PLATE RAMP	斜坡板	1	
		22132-GW0-0010	2	PIECE SLIDE	斜板邊件	3	
		28211-KEB7-9000	0	RATCHET KICK STARTER	起動齒盤	1	
		28223-KBN-9010	0	SPG KICK DRIVEN GEAR	起動惰齒輪彈簧	1	
		28230-GAK-9210	0	GEAR COMP KICK DRIVEN	起動惰齒輪組	1	
		28250-KCC-9000	0	SPINDLE COMP KICK STARTER	起動臂軸	1	
		28253-GN2-6020-M1	0	BUSH KICK SPINDLE	起動臂軸襯套	1	
		28255-GS6-0010	0	COLLAR KICK BOSS	套筒	1	
		28281-GN2-6030-M1	1	SPRING KICK RETURN	起動彈簧	1	
		90412-329-0010	0	WASHER THRUST 10MM	華司 10MM	1	
		90426-KBN-9010	0	WASHER SPECIAL 12MM	華司 12MM	1	
		90451-GN2-6010	0	WASHER KICK SPINDLE	華司	1	
		94001-12280-0S	0	NUT HEX 12MM	螺帽 12MM	1	
		94511-14000	0	CIRCLIP EX 14	夾環	1	

E 7 Driven Pulley

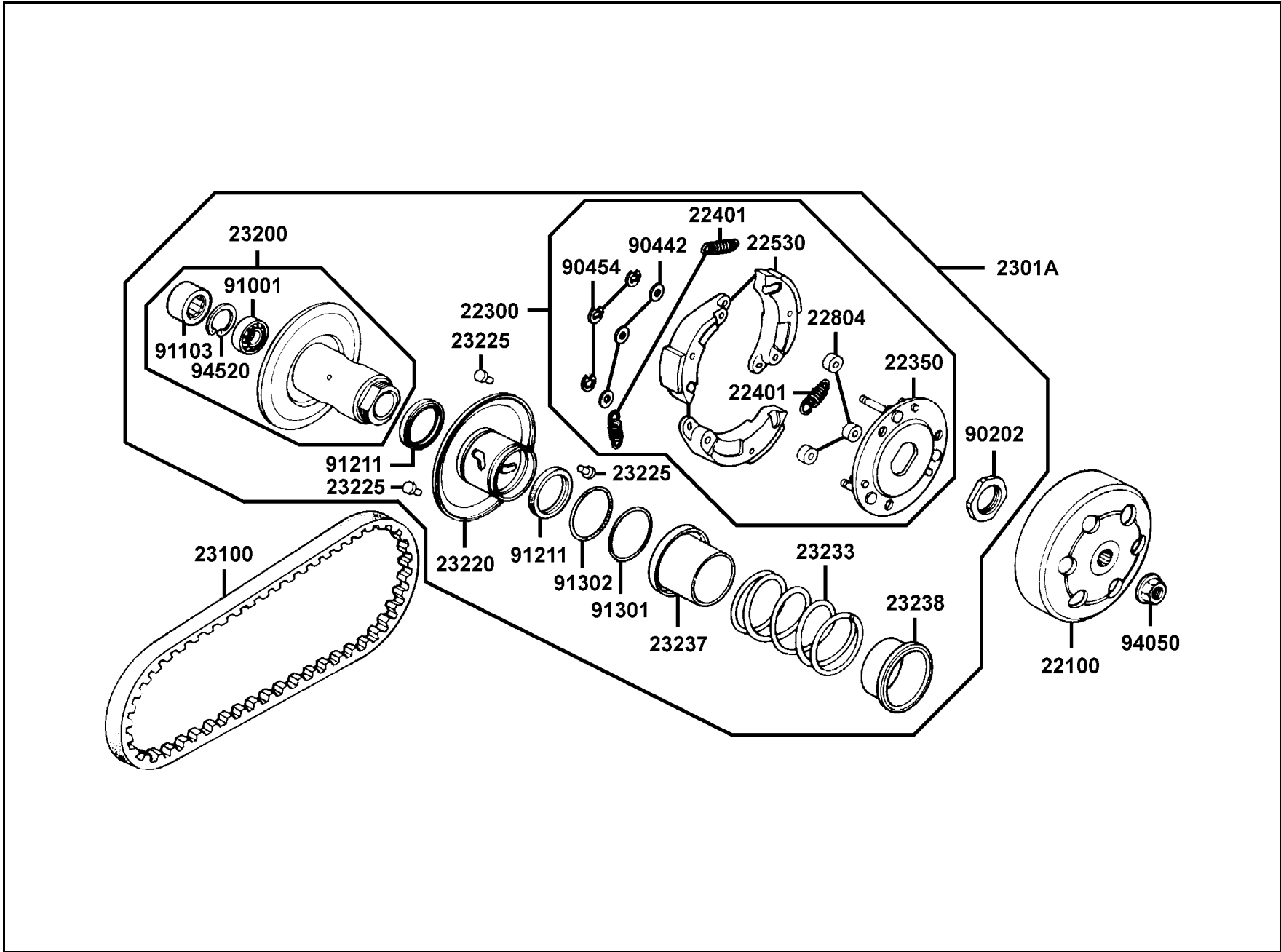

販賣記號	項目	零件號碼	版數	英文名稱	中文名稱	需要用量	參考價
Sales mark	Ref no	Part no	Ver	Description	Chinese	Regd no	Ref Price
		22100-GR1-7510	0	CLUTCH OUTER	離合器外套	1	
		22300-KCX-9000	0	PLATE ASSY DRIVE	驅動板組	1	
		22350-GAK-9300	1	PLATE COMP DRIVE	驅動板	1	
		22401-GG2-9000	0	SPRING CLUTCH	離合器彈簧	3	
		22530-GAK-9300	1	WEIGHT CLUTCH	離合配重	3	
		22804-148-0010	0	RUBBER CLUTCH DUMPER	橡皮	3	
		2301A-KEB7-2200	0	PULLEY SUB ASSY	從動皮帶輪組	1	
		23100-KEB7-9000	0	BELT DRIVE	驅動皮帶	1	
		23200-GR1-2200	0	FACE ASSY DRIVEN	從動皮帶盤組	1	
		23220-GAK-2200	0	FACE COMP MOVABLE DRIVEN	滑動式從動皮帶盤	1	
		23225-GR1-7510	0	PIN GUIDE	滾導銷	3	
		23233-GE8-0010	2	SPG DRIVEN FACE	驅動彈簧	1	
		23237-GR1-2200	0	COLLAR SEAL	套筒油封	1	
		23238-GY6-9410	0	COLLAR SPG	套筒	1	
		90202-187-0010	0	NUT SPECIAL 28MM	螺帽 28MM	1	
		90442-044-0000	0	WASHER THRUST 6MM	華司	3	
		90454-GB2-0000	0	CIRCLIP 6MM	環夾 6MM	3	
		91001-GA7-70A	0	BRG RADIAL BALL 6901U	軸承 6901	1	
		91103-GR1-004	0	BRG NEEDLE 17*25*18 WS	滾針軸承 17*25*18	1	
		91211-GK8-0130	0	OIL SEAL 34*39*3	驅動油封 34*39*3	2	

E 7 Driven Pulley

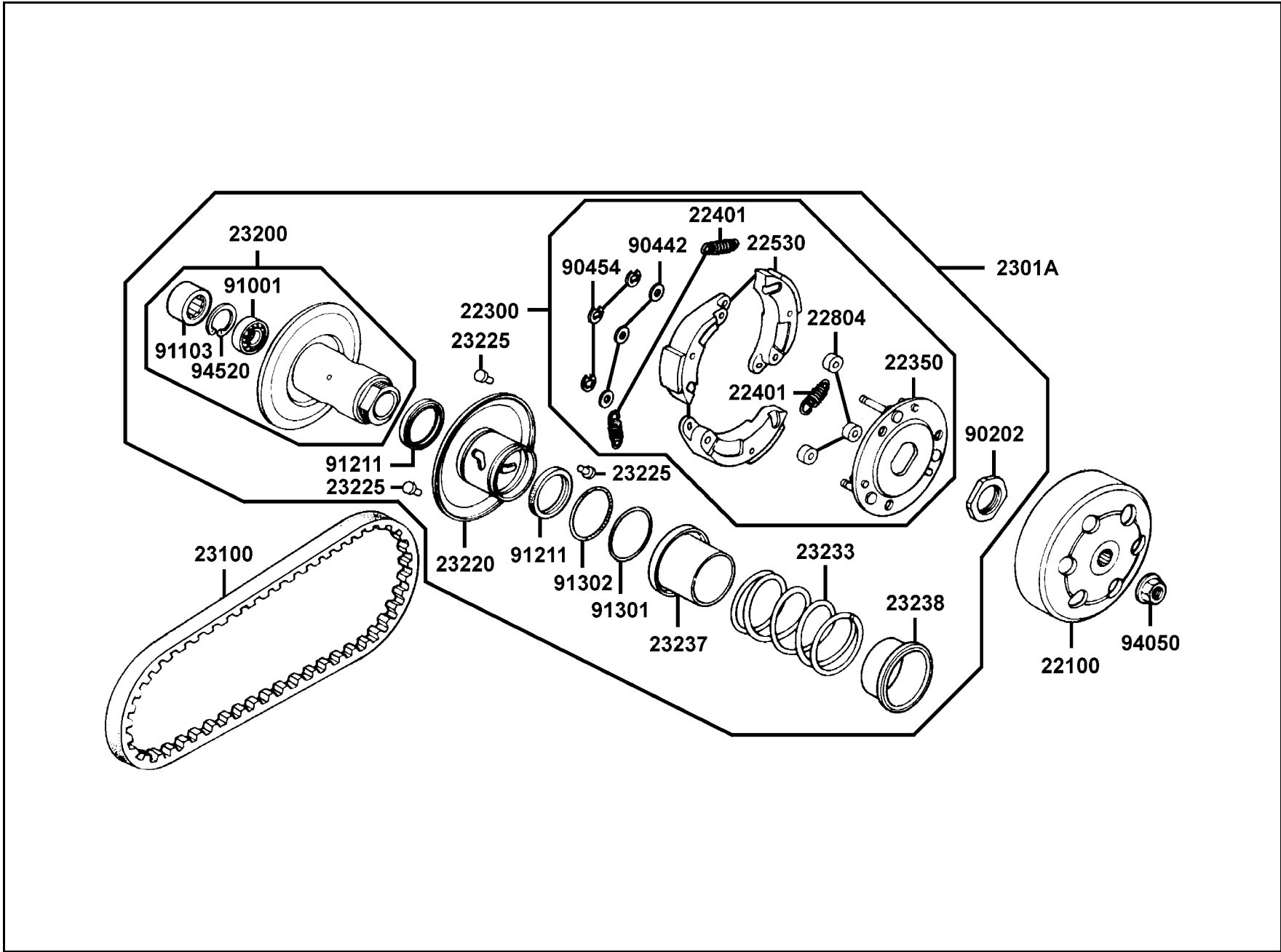

販賣記號	項目	零件號碼	版數	英 文 名 稱	中 文 名 稱	需要用量	參考價
Sales mark	Ref no	Part no	Ver	Description	Chinese	Regd no	Ref Price
		91301-KA5-7420-Y1	0	O-RING 36*1.5	O環 36*1.5	1	
		91302-PA9-0040	0	O-RING 39.8*2.2	O環 39.8*2.2	1	
		94050-10080	0	NUT FLANGE 10MM	螺帽 10MM	1	
		94520-24000	0	CIR CLIP IN 24	內環夾 24MM	1	

E 7

E 8 Transmission

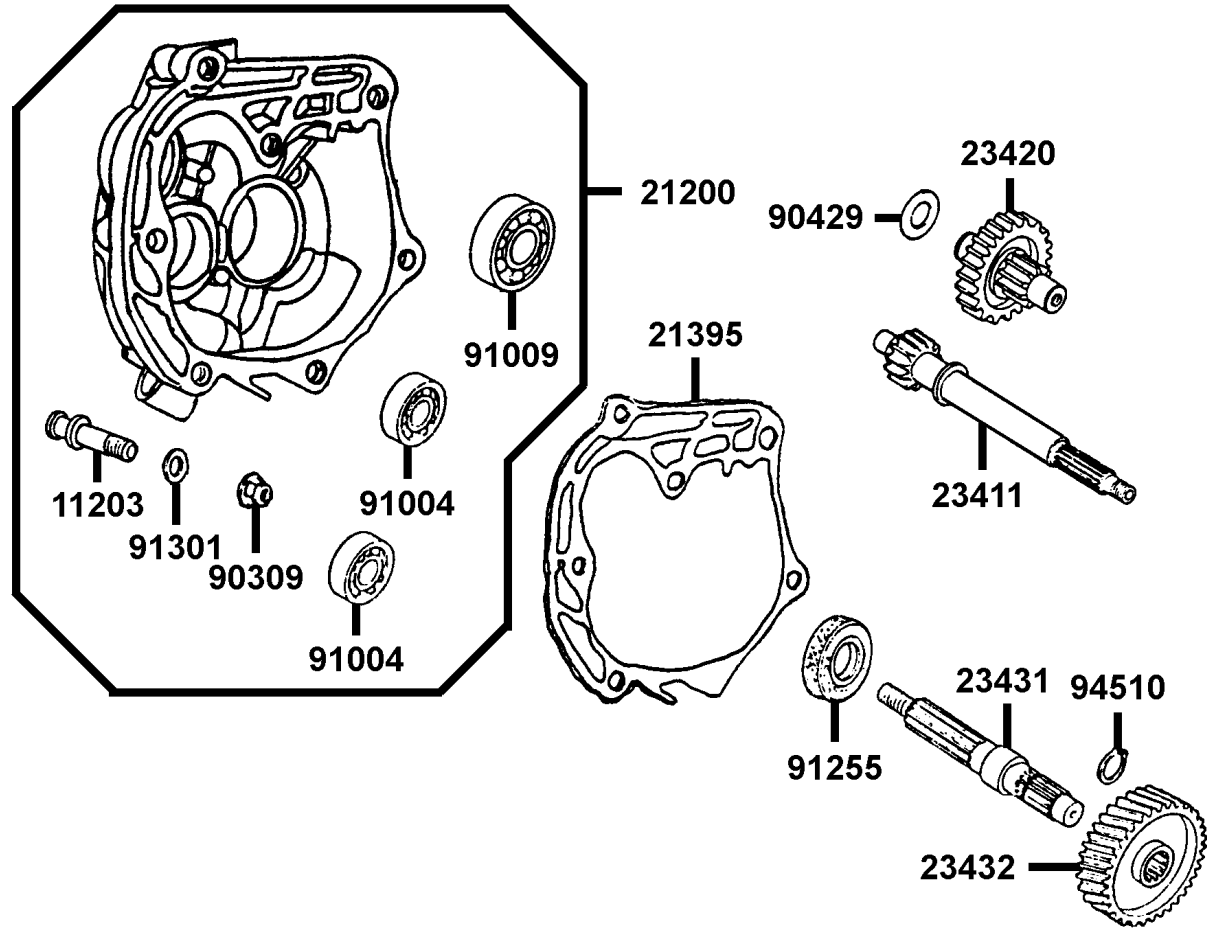

販賣記號	項目	零件號碼	版數	英文名稱	中文名稱	需要用量	參考價
Sales mark	Ref no	Part no	Ver	Description	Chinese	Regd no	Ref Price
		11203-KDU-9000	0	PIN BRAKE SHOE ANCHOR	煞車鼓固定銷	1	
		21200-KFA6-3050	0	CASE COMP MISSION	主軸蓋組	1	
		21395-KFA6-9000	0	GASKET MISSION CASE A	主軸蓋墊片 A	1	
		23411-KFA6-9000	0	SHAFT DRIVE	驅動軸	1	
		23420-KFA6-9000	0	SHAFT COMP COUNTER	副軸組	1	
		23431-KBN-9010-H1	1	SHAFT FINAL	最終軸	1	
		23432-KFA6-9000	0	GEAR FINAL	最終齒輪	1	
		90309-KF0-0030	1	NUT FLANGE 8MM	平螺帽 8MM	1	
		90429-KBN-9010	0	WASHER SIDE 12MM	華司 12MM	1	
		91004-KN2-90A	0	BRG BALL RADIAL 6201	軸承 6201	2	
		91009-GE0-0040	0	BRG BALL RADIAL 6004 UU	軸承 6004	1	
		91255-GE0-0060	0	OIL SEAL 27*42*7	油封 27*42*7	1	
		91301-053-0010	0	O RING 7.5*1.5	O環 7.5*1.5	1	
		94510-20000	0	CIR CLIP EX 20	夾環	1	

E 9 Crankcase Oil Pump

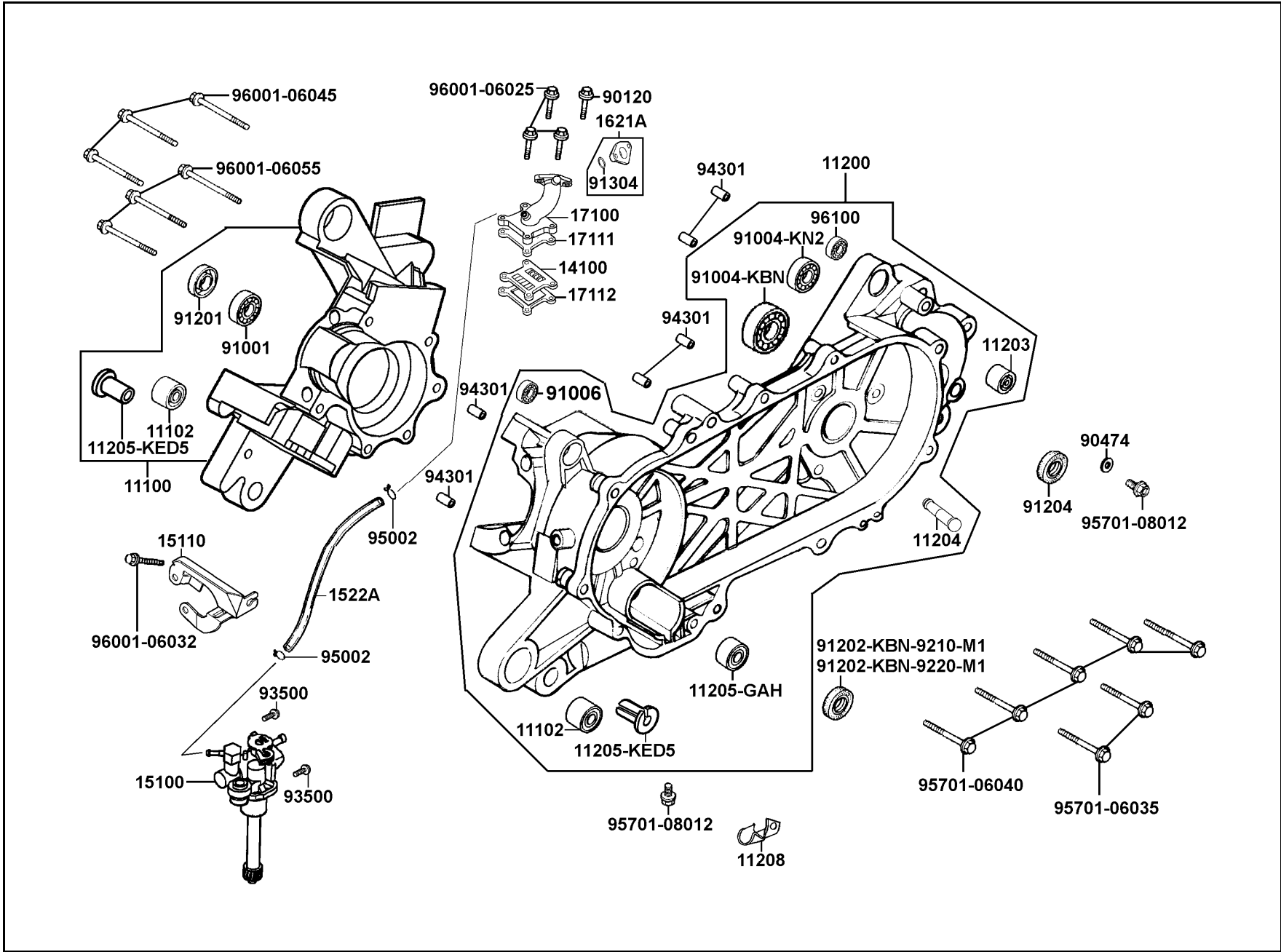

販賣記號	項目	零件號碼	版數	英文名稱	中文名稱	需要用量	參考價
Sales mark	Ref no	Part no	Ver	Description	Chinese	Regd no	Ref Price
		11100-KEB7-3250	5	CRANK CASE ASSY RIGHT	右曲軸箱組	1	
		11102-187-0030	3	RUB BUSH ENG HANGER	引擎吊架襯套	2	
		11200-KFA6-305	1	CRANK CASE ASSY L	左曲軸箱組	1	
		11203-GC7-3010	2	UNDER RUBBER BUSH REAR CUSHION	後緩衝下襯套	1	
		11204-KEB7-9000-H1	0	PIN SPG HOOK	固定銷	1	
		11205-GAH-0040-H1	0	BUSH 8*12*8	襯套 8*12*8	1	
		11205-KED5-9000-H1	0	BUSH M STAND	襯套	2	
		11208-GAK-9010	0	CLAMPER CARB DRAIN	管夾	1	
		14100-KEB7-9000	0	VALVE COMP REED	簧片閥門	1	
		15100-KEB7-E000	0	PUMP ASSY OIL	機油泵浦組	1	
		15110-KEB7-9000	0	PLATE OIL PUMP SET	機油泵支架	1	
		1552A-KEB7-9010	0	TUBE ASSY OIL PASS	噴合油管組	1	
		1621A-GAK-9010	0	INSULATOR CARB ASSY	絕緣器	1	
		17100-KEB7-E000-GM	0	PIPE COMP INLET	進氣管	1	
		17111-KEB7-9000	0	GASKET INLET PIPE A	進氣管墊片 A	1	
		17112-KEB7-900	1	GASKET INLET PIPE B	簧片閥門墊片 B	1	
		90120-GR1-J000	0	SOCKET BOLT SPECIAL 6*28	螺絲 6*28	1	
		90474-333-0010	0	WASHER 8MM	華司 8MM	1	
		91001-GW0-90A	1	BRG BALL RADIAL 6204 SPECIAL	軸承 6204	1	
		91004-KBN-92A	0	BRG BALL RADIAL 6203SPC	軸承 6203	1	

E 9 Crankcase Oil Pump

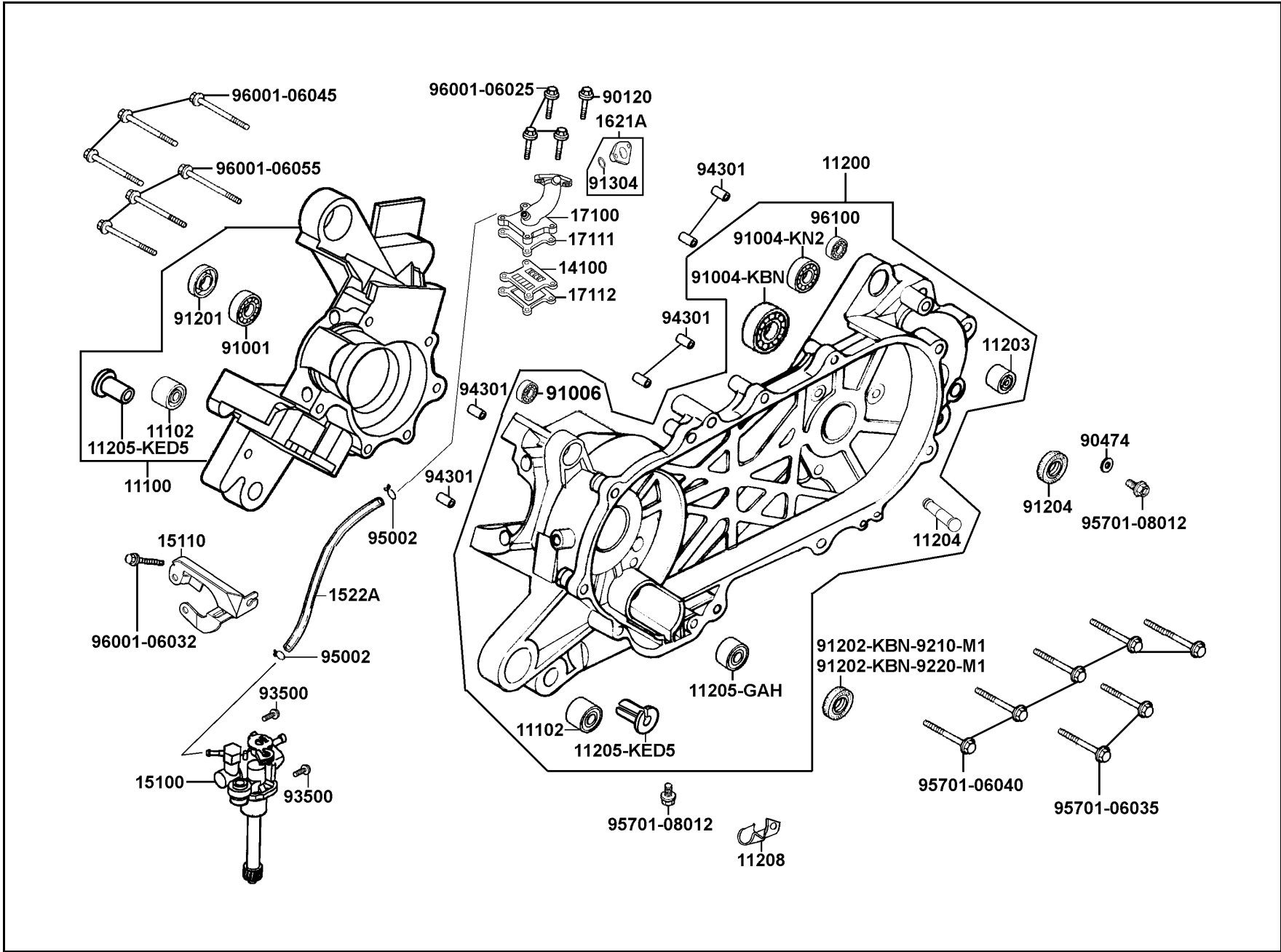

販賣記號 Sales mark	項目 Ref no	零件號碼 Part no	版數 Ver	英 文 名 稱 Description	中 文 名 稱 Chinese	需要用量 Regd no	參考價 Ref Price
		91004-KN2-90A	0	BRG BALL RADIAL 6201	軸承 6201	1	
		91006-KBN-901	4	BRG BALL RADIAL 25*56*12	軸承 25*56*12	1	
		91201-KBN-9220-M1	0	OIL SEAL 15.6*25.5*7	油封 15.6*25.5*7	1	
		91202-KBN-9210-M1	0	OIL SEAL 20*31*7	油封 20*31*7	1	
		91202-KBN-9220-M1	0	OIL SEAL 20*31*7	油封 20*31*7	1	
		91204-KBN-9020-M1	1	OIL SEAL 17*30*6	油封 17*30.6	1	
		91304-GB0-9110	1	O RING 20.6*1.9	O環 20.6*1.9	1	
		93500-05012-0H	0	SCREW PAN 5*12	螺絲 5*12	2	
		94301-10200	0	DOWEL PIN 10*20	插銷 10*20	6	
		95002-02650	0	CLIP B6.5 TUBE	管夾	2	
		95701-06035-08	0	BOLT FLANGE 8*35	螺絲 8*35	2	
		95701-06040-08	0	BOLT FLANGE 8*40	螺絲 8*40	5	
		95701-08012-08	0	BOLT FLANGE 8*12	螺絲 8*12	2	
		96001-06025-08	0	BOLT FLANGE SH 6*25	螺絲 6*25	3	
		96001-06032-08	0	BOLT FLANGE SH 6*32	螺絲 6*32	1	
		96001-06045-08	0	BOLT FLANGE SH 6*45	螺絲 6*45	3	
		96001-06055-08	0	BOLT FLANGE SH 6*55	螺絲 6*25	3	
		96100-62033-00	0	BEARING BALL RADIAL 6203	徑向滾珠軸承 6203	1	

E 10 Crankshaft●Piston

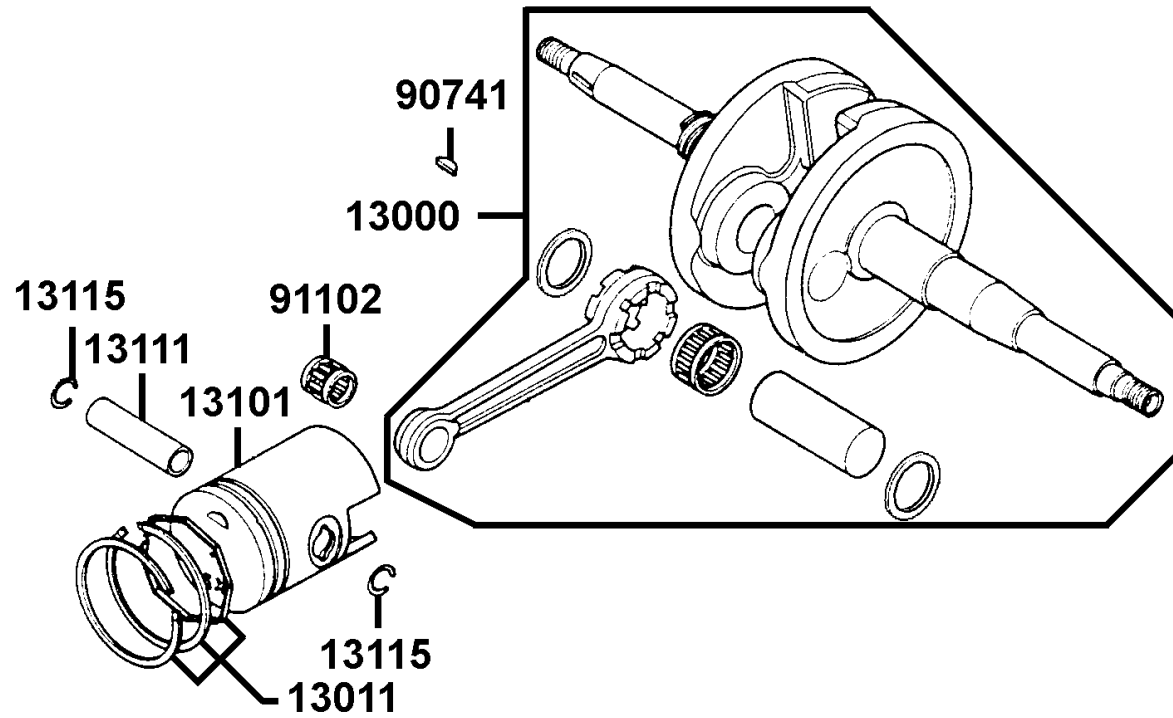

販賣記號	項目	零件號碼	版數	英文名稱	中文名稱	需要用量	參考價
Sales mark	Ref no	Part no	Ver	Description	Chinese	Regd no	Ref Price
		13000-GAK-921	6	CRANK SHAFT COMP	曲軸	1	
		13011-GW0-9020	0	RING SET PISTON	活塞環組	1	
		13101-GW0-9010	1	PISTON	活塞	1	
		13111-166-0010	1	PIN PISTON	活塞銷	1	
		13115-156-0010	0	CLIP PISTON PIN 12MM	活塞銷夾 12MM	2	
		90741-035-0010	0	KEY WOODRUFF	固定鍵	1	
		91102-GW0-009	0	BRG CON-ROD S. E.	連桿小端軸承	1	

E 11 Carburetor

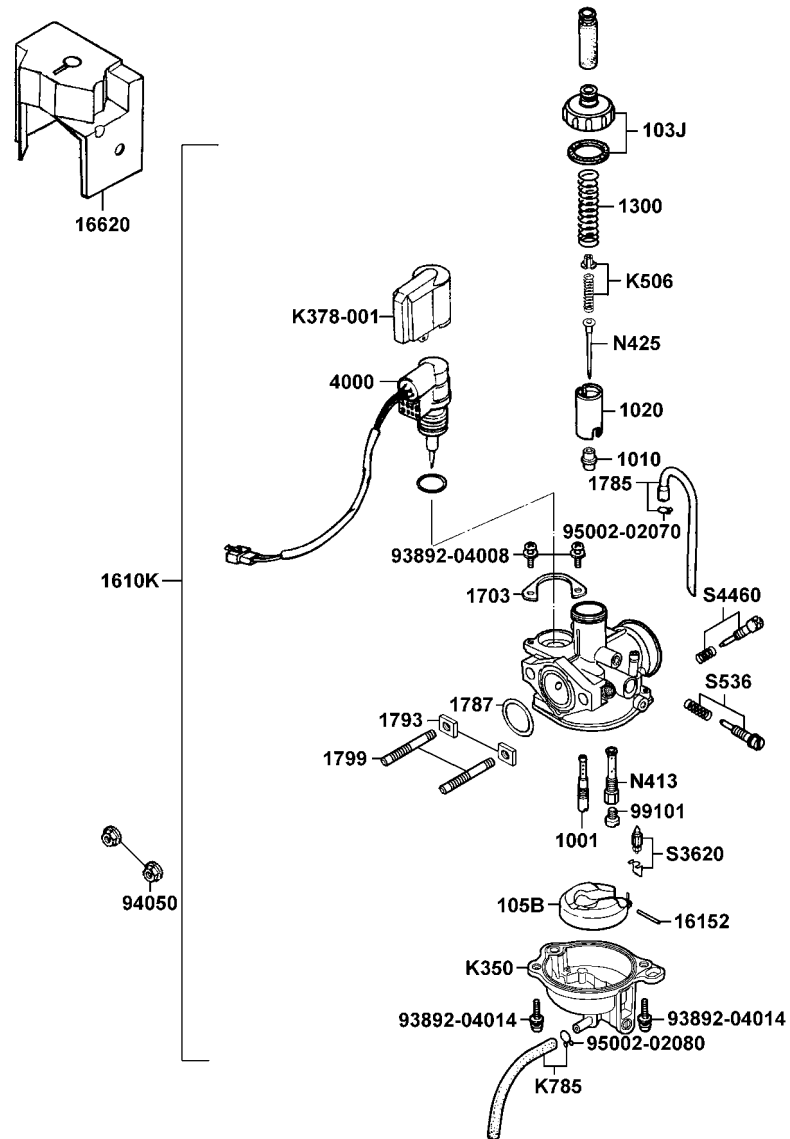

販賣記號	項目	零件號碼	版數	英文名稱	中文名稱	需要用量	參考價
Sales mark	Ref no	Part no	Ver	Description	Chinese	Regd no	Ref Price
		1001-GC8H-0351	0	SLOW JET	慢速噴油嘴	1	
		1010-GAKH-9200	0	NEEDLE JET	油針噴嘴	1	
		1020-GAKH-9300	0	THROTTLE VALVE	節流活塞閥	1	
		103J-073H-9900-SB00	0	TOP SET	節流活塞閥蓋	1	
		105B-KBNH-9000	0	FLOAT COMP	浮筒組	1	
		1300-GW0H-9000	0	SPG COMPR	彈簧	1	
		1610K-KFA6-E500	1	CARBURETOR ASSY	化油器	1	
		16152-KG8-9010-M1	0	ARM PIN	浮筒閥臂銷	1	
		16620-KEB7-E000	1	CAP CARBURETOR	化油器護蓋	1	
		1703-GJ2H-0040	0	SET PLATE	固定板	1	
		1785-KBNH-9000-SB00	0	TUBE SET	空氣管	1	
		1787-KG8H-9010	0	O-RING	O環	1	
		1793-144H-9900	0	HEX NUT	螺帽	2	
		1799-KBNH-9000	0	STUD BOLT	雙頭螺絲	2	
		4000-077-0000	0	AUTO BYSTARTER SET	自動旁通器組	1	
		93892-04008-18	0	SCREW WASHER 4*8	螺絲 4*8	2	
		93892-04014-18	0	SCREW WASHER	螺絲	2	
		94050-06080	0	NUT FLANGE 6MM	螺帽 6MM	2	
		95002-02070	0	CLIP TUBE B7	管夾	1	
		95002-02080	0	CLIP TUBE B7	管夾	1	

E 11 Carburetor

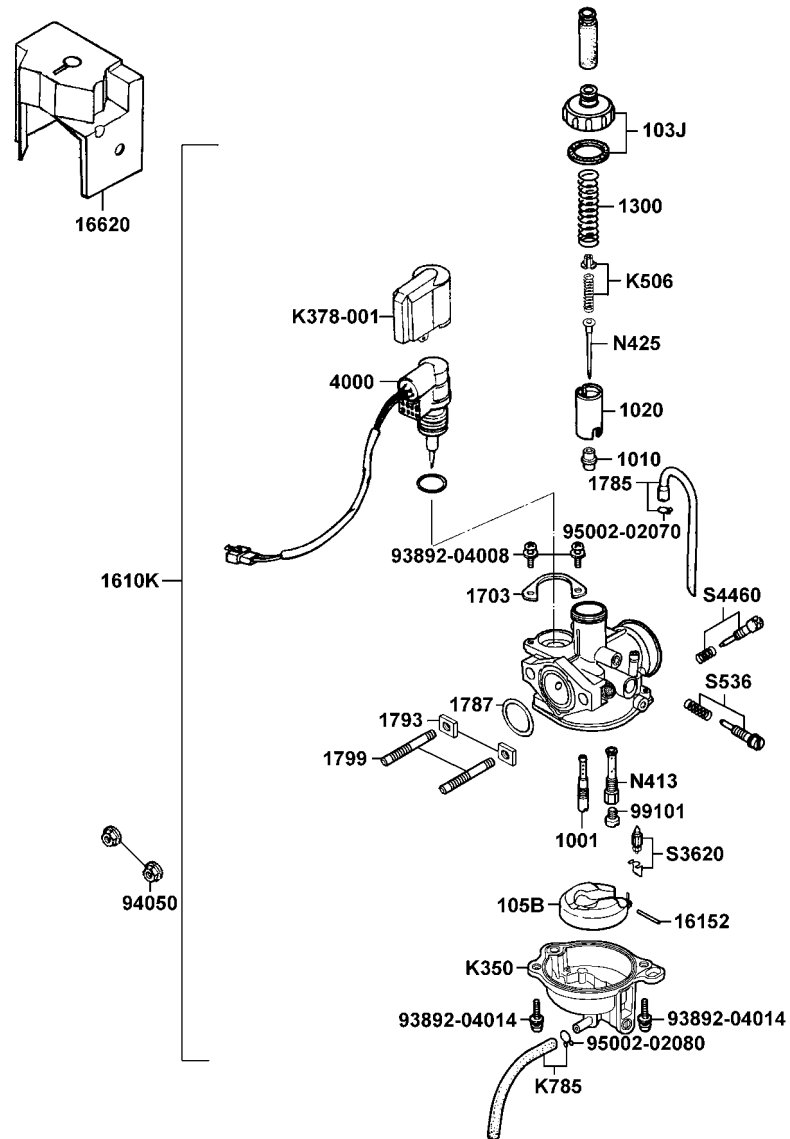

販賣記號	項目	零件號碼	版數	英文名稱	中文名稱	需要用量	參考價
Sales mark	Ref no	Part no	Ver	Description	Chinese	Regd no	Ref Price
		99101-116-0700	0	MAIN JET	主噴油針	1	
		K350-KEB-0500	0	FLOAT CHAMBER SET	浮筒室組	1	
		K378-001	0	CAP ASSY	保護蓋	1	
		K506-GW0-0100	0	VALVE PLATE SET	安全閥固定板組	1	
		K785-KEB-0300	0	TUBE SET	溢流管	1	
		N413-32A00	0	NEEDLE JET HOLDER	油針座	1	
		N425-2RFMJ	0	NEEDLE JET COMP	油針	1	
		S3620-031-B000	0	FLOAT VALVE SET	浮筒閥	1	
		S4460-213-B001	0	SCREW SET	螺絲組	1	
		S536-1241	0	SCREW SET	螺絲組	1	

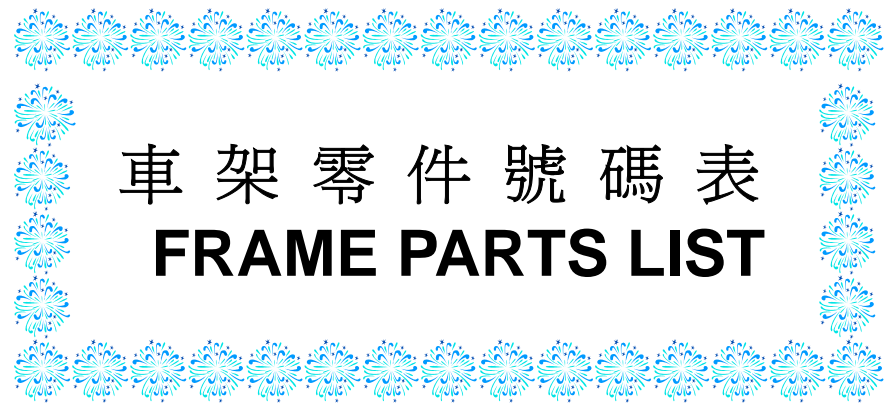

車架零件號碼表
FRAME PARTS LIST

F 1 Head Light

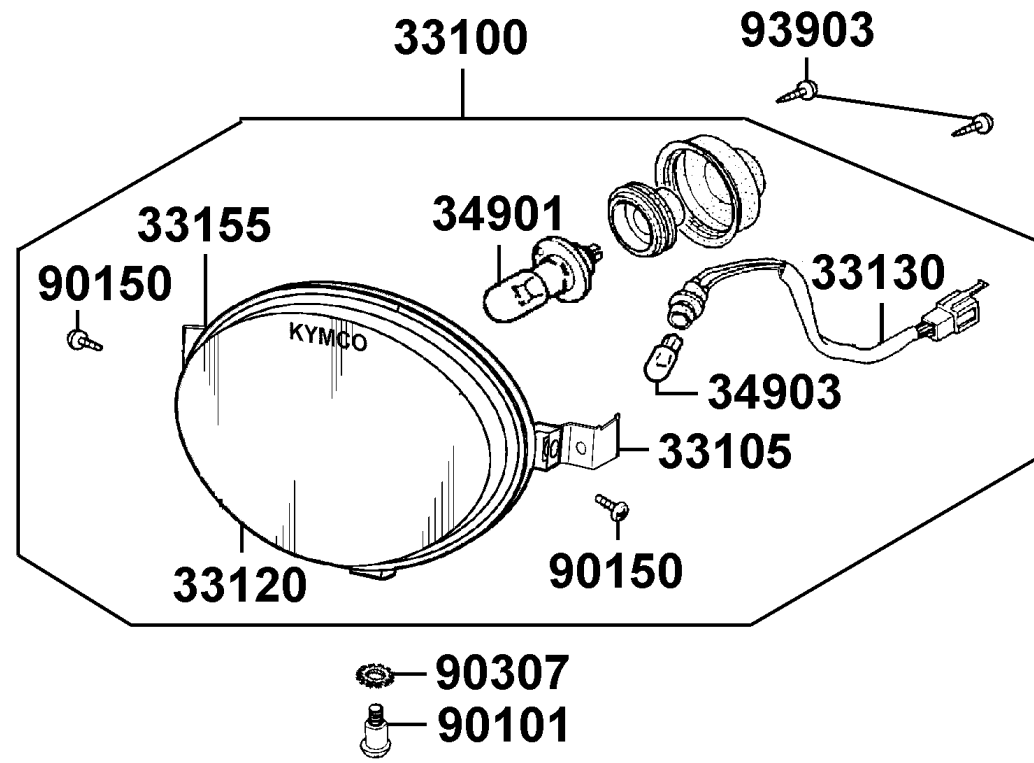

F 1

販賣記號	項目	零件號碼	版數	英文名稱	中文名稱	需要用量	參考價
Sales mark	Ref no	Part no	Ver	Description	Chinese	Regd no	Ref Price
		33100-KFA6-9000	0	LIGHT ASSY HEAD	前燈組	1	
		33105-KFA6-900	0	PLATE ADJUST (LH)	前燈左調整板	1	
		33120-KFA6-9000	0	UNIT HEAD LIGHT	前燈殼	1	
		33130-KFA6-9000	0	SOCKET COMP	前燈配線	1	
		33155-KFA6-900	0	PLATE ADJUST (RH)	前燈右調整板	1	
		34901-KFA6-9000	0	BULB HEAD LIGHT	前燈泡	1	
		34903-KCP-9000	0	BULB POSITION	位置燈泡	1	
		90101-GR1-0010	0	BOLT ADJUST	螺絲	1	
		90150-463-7710-M1	0	SCREW PAN	螺絲	2	
		90307-GJ6-0040	0	WASHER LOCK 6MM	華司 6MM	1	
		93903-35220	0	SCREW TAPPING 5*12	螺釘 5*12	2	

F 2 Speedometer

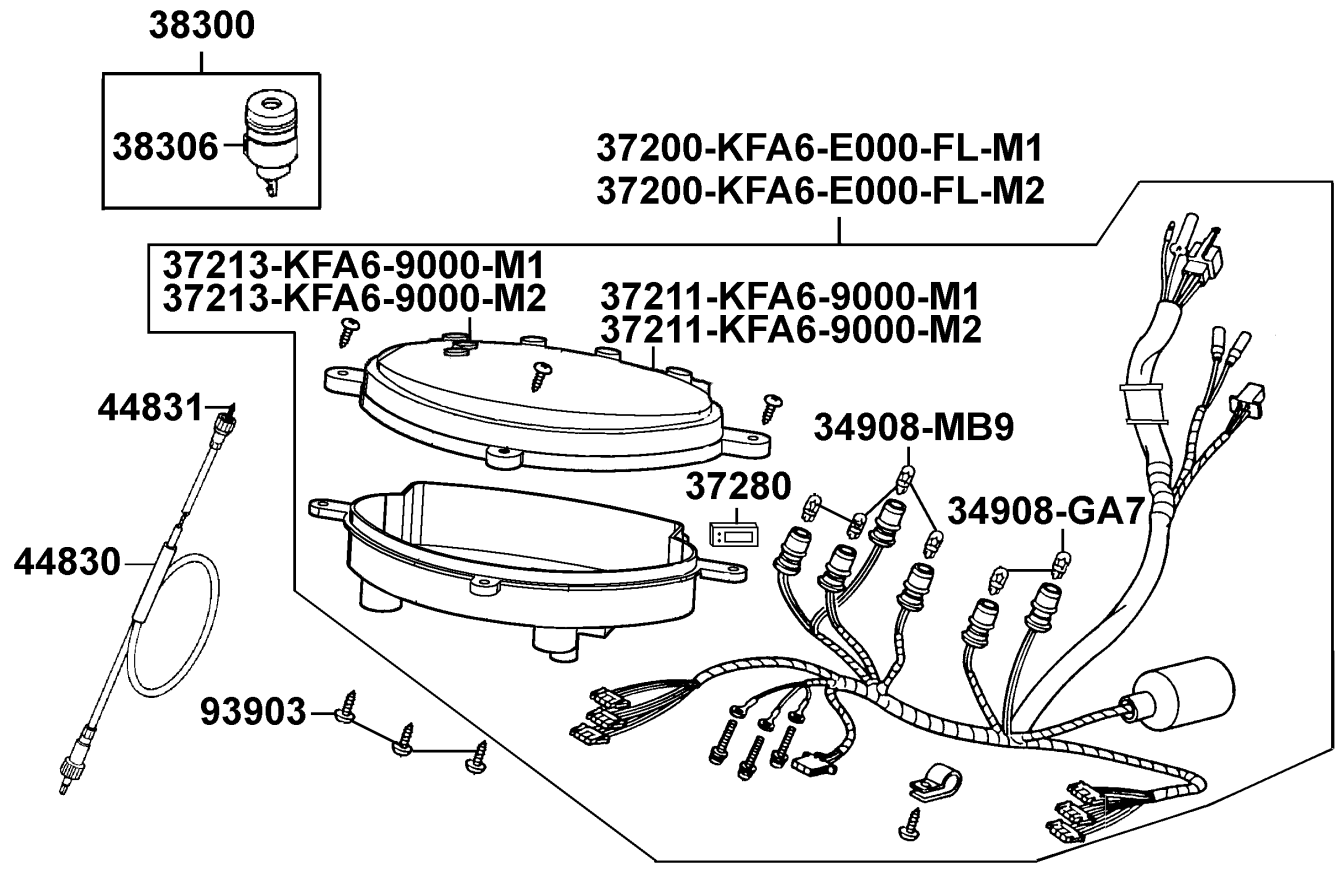

販賣記號	項目	零件號碼	版數	英 文 名 稱	中 文 名 稱	需要用量	參考價
Sales mark	Ref no	Part no	Ver	Description	Chinese	Regd no	Ref Price
		34908-GA7-7010-M1	1	BULB WEDGE BASE	儀錶內燈泡	2	
		34908-MB9-8710-M1	0	BULB WEDGE BASE	儀錶內燈泡	4	
		37200-KFA6-E000-FL-M1	2	METER ASSY SPEED	儀錶組	1	
		37200-KFA6-E000-FL-M2	1	METER ASSY SPEED	儀錶組	1	
		37211-KFA6-9000-M1	0	LENS ASSY	儀錶蓋	1	
		37211-KFA6-9000-M2	0	LENS ASSY	儀錶蓋	1	
		37213-KFA6-9000-M1	0	PACKING (LCD)	電子鐘按鍵	1	
		37213-KFA6-9000-M2	0	PACKING (LCD)	電子鐘按鍵	1	
		37280-KFA6-9000	0	LCD ASSY (LOCK)	電子時鐘	1	
		38300-KCE-9000	1	RELAY ASSY WINKER	方向燈繼電器	1	
		38306-292-C110	0	SUSPENSION WINKER RELAY	方向燈繼電器懸掛橡皮	1	
		44830-KFA6-9000	0	CABLE COMP SPDMT	速度錶導線	1	
		44831-KFA6-9000	0	CABLE INNER	速度錶內導線	1	
		93903-35320	0	SCREW TAPPING 5*16	螺釘 5*16	3	

F 3 Handle Steering ● Handle Cover

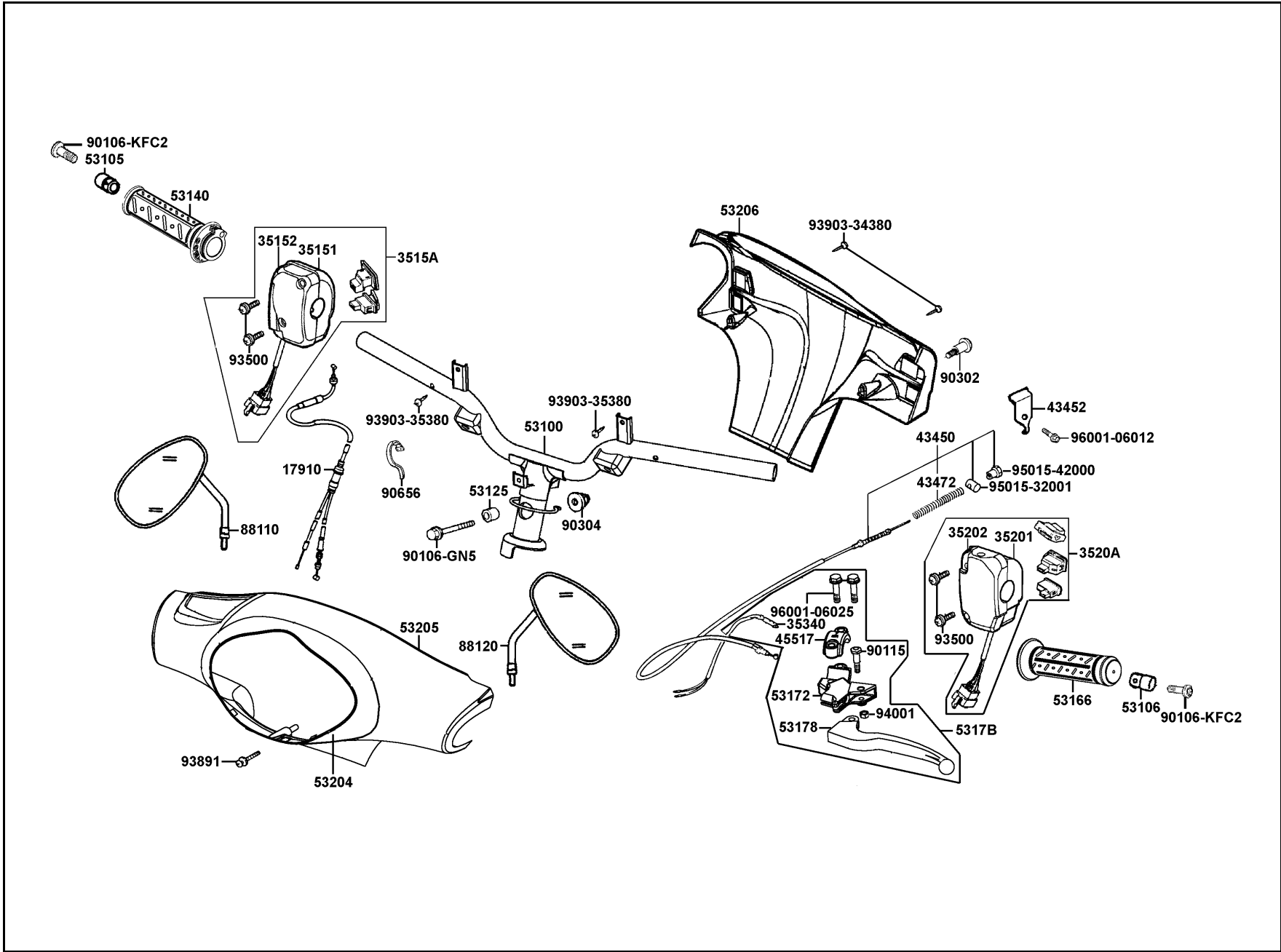

販賣記號	項目	零件號碼	版數	英 文 名 稱	中 文 名 稱	需要用量	參考價
Sales mark	Ref no	Part no	Ver	Description	Chinese	Regd no	Ref Price
		17910-KFA6-9000	0	CABLE COMP THROT	節流導線	1	
		3515A-KGBG-E000	2	SW ASSY RH HNDL COMP	手柄右邊開關組	1	
		35151-KGBG-9100	1	FR CASE RH HANDLE COMP SW	手柄右開關前本體	1	
		35152-KGBG-9000	2	RR CASE RH HANDLE COMP SW	手柄右開關後本體	1	
		35201-KGBG-9100	1	FR CASE LH HANDLE COMP SW	手柄左開關前本體	1	
		35202-KGBG-9000	2	RR CASE LH HANDLE COMP SW	手柄左開關後本體	1	
		3520A-KGBG-E00	3	SW ASSY LH HNDL COMP	手柄左邊開關組	1	
		35340-KJ9-0100	4	SW ASSY FR STOP	剎車燈前置開關組	1	
		43450-KFA6-9000	1	CABLE COMP RR BRK	後煞車導線	1	
		43452-GAK-9000	0	CLAMP BRK CABLE	導線夾	1	
		43472-161-0010	0	SPG RR BRK ARM	煞車彈簧	1	
		45517-GY6-9000	5	HOLDER HNDL BRKT	手柄固定座夾板	1	
		53100-KHB4-9000	2	HANDLE COMP STRG	轉向手柄	1	
		53105-KFC8-9000	2	END R STRG HANDLE	手柄右平衡端子	1	
		53106-KFC8-9000	0	END L STRG HANDLE	手柄左平衡端子	1	
		53125-GN5-9010	0	COLLAR HANDLE SET	套筒	1	
**		53140-KBN-960	0	GRIP COMP THROT	節流管套組	1	
**		53166-KBN-910	0	GRIP L HANDLE	手柄左橡皮套	1	
		53172-KCT-9000	0	BRKT HNDL L	手柄左托架	1	
**		53178-KFA6-900	0	LEVER L STRG HNDL	手柄左拉桿	1	

F 3 Handle Steering ● Handle Cover

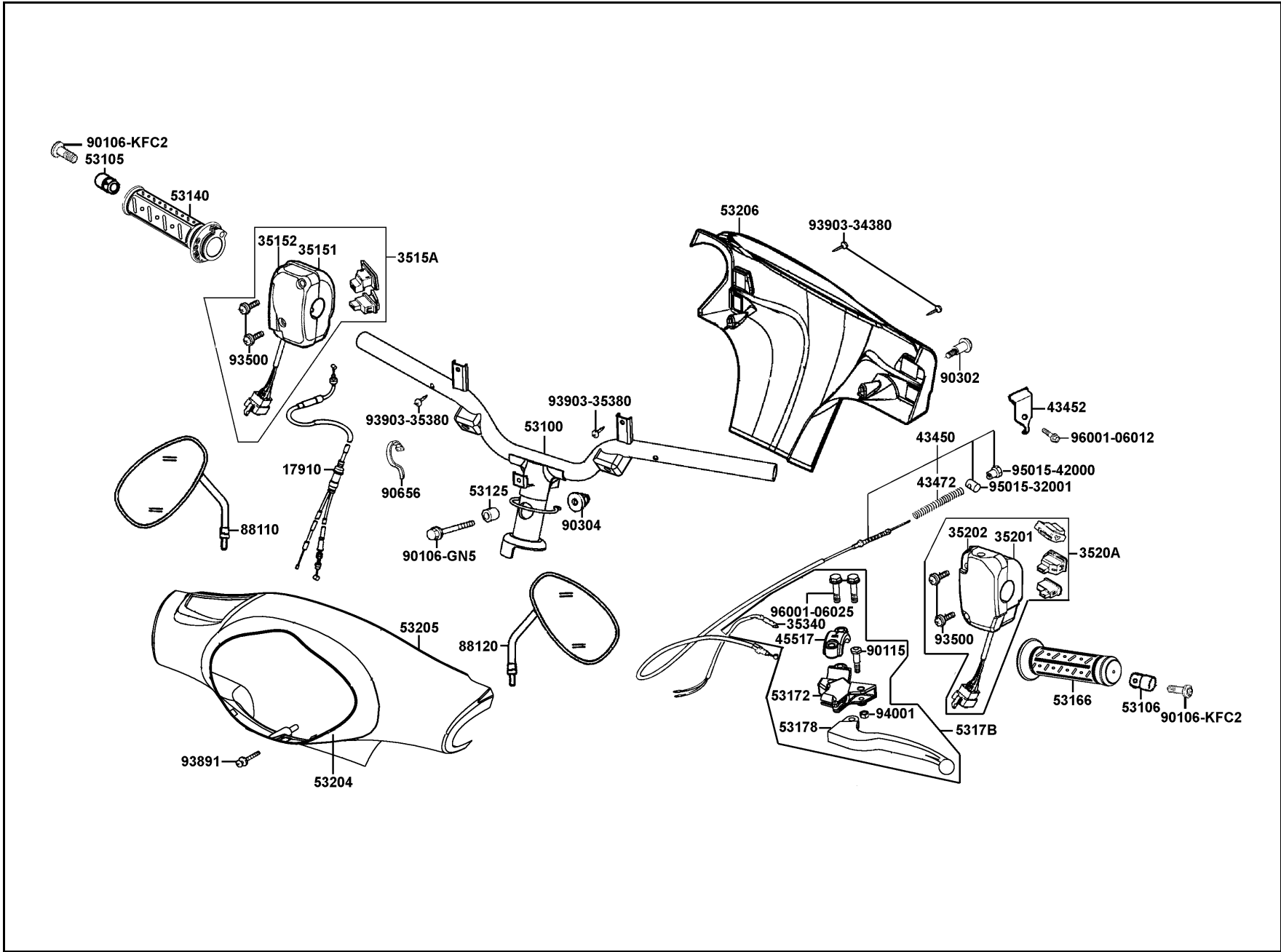

販賣記號 Sales mark	項目 Ref no	零件號碼 Part no	版數 Ver	英 文 名 稱 Description	中 文 名 稱 Chinese	需要用量 Regd no	參考價 Ref Price
		5317B-KFA6-9000	0	BRKT ASSY HNDL L	手柄左托架組	1	
		53204-KFA6-9000	0	COVER HEAD LIGHT	前燈蓋	1	
**		53205-KFA6-E00	0	COVER FR HANDLE	手柄前蓋	1	
**		53206-KFA6-900	1	COVER RR HANDLE	手柄後蓋	1	
		88110-KFA6-9000	1	MIRROR ASSY R BACK	右後視鏡	1	
		88120-KFA6-9000	1	MIRROR ASSY L BACK	左後視鏡	1	
		90106-GN5-9010	0	BOLT FLANGE 10*50	特殊螺絲 10*50	1	
		90106-KFC2-9000	0	BOLT WASH 8MM	螺絲 8MM	2	
		90115-GE0-0010	0	BOLT HNDL LEVER PIVOT	拉桿螺絲	1	
		90302-KBN-9000	0	BOLT PAN 5*10	螺絲 5*10	1	
		90304-GE8-0040	0	NUT U 10MM	螺帽 10MM	1	
		90656-GY6-9110	0	BAND OIL HOSE	油管束帶	1	
		93500-KGBG-9000	0	SCREW TAPPING M 5*25L	螺絲 5*25	4	
		93891-05030-07	0	SCREW WASHER 5*30	螺絲 5*30	1	
		93903-34380	0	SCREW TAPPING 4*12	螺釘 4*12	2	
		93903-35380	0	SCREW TAPPING 5*16	螺絲 5*16	2	
		94001-05080-0S	0	NUT HEX 5MM	螺帽 5MM	1	
		95015-32001	0	JOINT B BRAKE ARM	煞車導線接頭銷	1	
		95015-42000	0	NUT B ADJUST	調整螺帽	1	
		96001-06012-08	0	BOLT FLANGE SH 6*12	螺絲 6*12	1	

F 3 Handle Steering ● Handle Cover

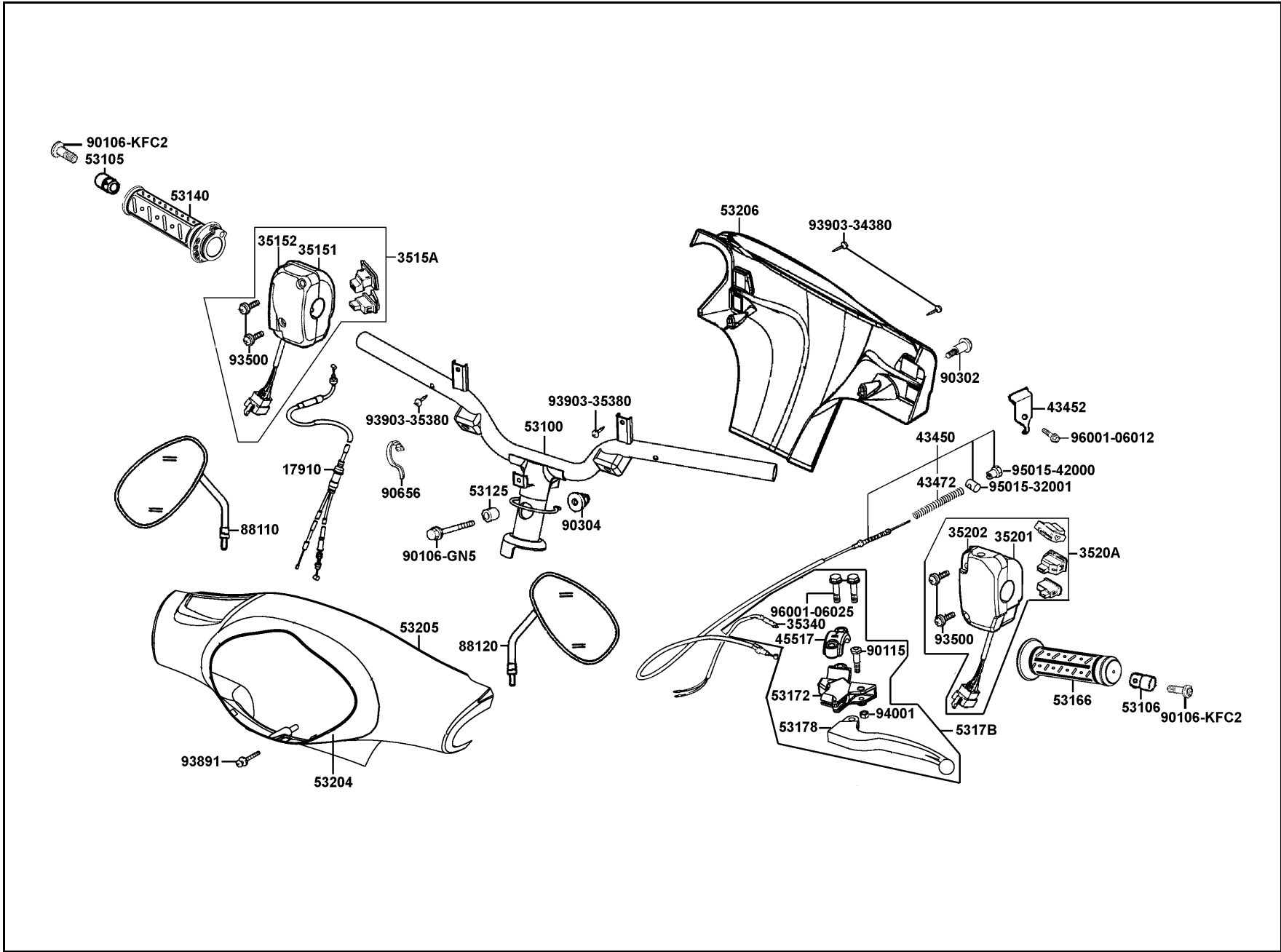

販賣記號	項目	零件號碼	版數	英 文 名 稱	中 文 名 稱	需要用量	參考價
Sales mark	Ref no	Part no	Ver	Description	Chinese	Regd no	Ref Price
		96001-06025-07	0	BOLT FLANGE 6*25	螺絲 6*25	2	

F 3

F 4 Brake Master Cylinder

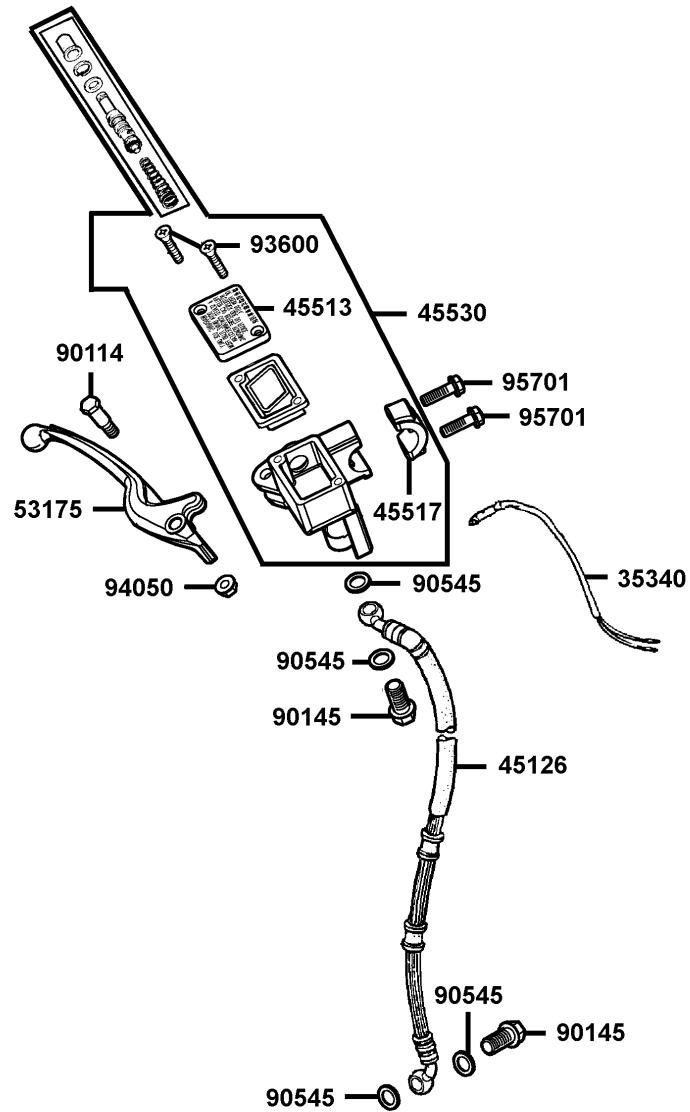

販賣記號	項目	零件號碼	版數	英文名稱	中文名稱	需要用量	參考價
Sales mark	Ref no	Part no	Ver	Description	Chinese	Regd no	Ref Price
		35340-KFA6-900	0	SW ASSY FR STOP	煞車燈前置開關	1	
		45126-KFA6-9000	1	HOSE ASSY FR BRK	前煞車油管	1	
		45513-KFA6-800	0	CAP M/C	煞車主油缸蓋	1	
		45517-KAF-9100	0	HOLDER M/C	主油缸固定座	1	
		45530-KFA6-3050-US	0	CYLINDER SET MASTER	前煞車主油缸組	1	
**		53175-KFA6-900	0	LEVER R STRG HNDL	手柄右拉桿	1	
		90114-166-0070	1	BOLT HANDLE LEVER	右拉桿固定螺絲	1	
		90145-MS9-6120-M1	0	OIL BOLT 10*22	油管螺絲 10*22	2	
		90545-300-0010	2	WASHER OIL BOLT	華司	4	
		93600-04012-1G	0	SCREW FLAT 4*12	螺絲 4*12	2	
		94050-06070	0	NUT FLANGE 6MM	螺帽 6MM	1	
		95701-06022-07	0	BOLT FLANGE 6*22	螺絲 6*22	2	

F 5 Front Cover●Floor Panel

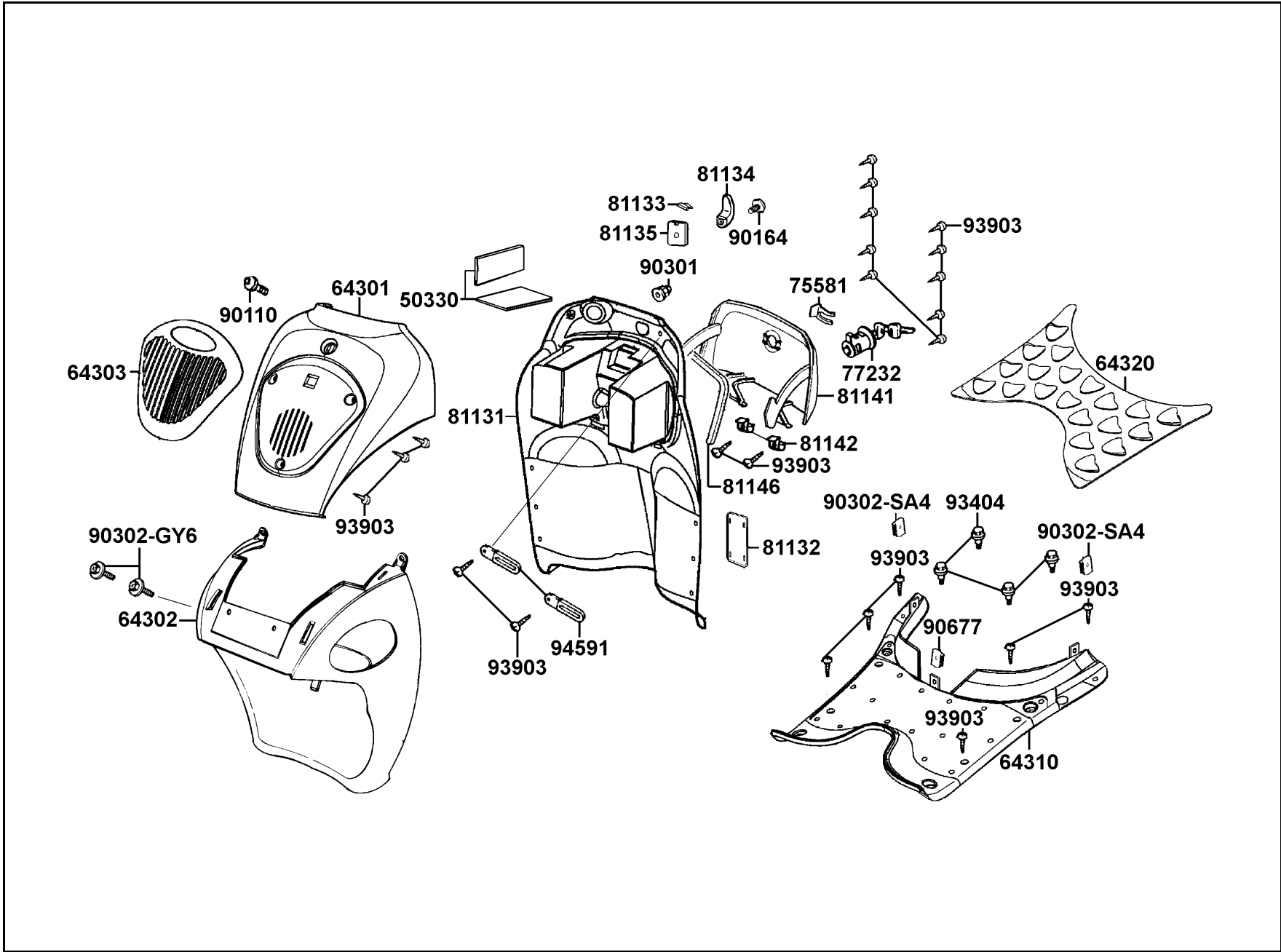

販賣記號	項目	零件號碼	版數	英文名稱	中文名稱	需要用量	參考價
Sales mark	Ref no	Part no	Ver	Description	Chinese	Regd no	Ref Price
		50330-KBE-9000	0	SEAL BATTERY FR	油封	2	
**		64301-KFA6-900	2	COVER FRONT	前護蓋	1	
**		64302-KFA6-900	1	MOLD FRONT	前邊條	1	
		64303-KFA6-9000	0	GRILL FRONT COVER	前護蓋通氣窗	1	
**		64310-KFA6-900	2	FLOOR PANEL	腳踏板	1	
**		64320-KFA6-900	0	MAT FLOOR	腳踏板墊	1	
		75581-673-0010	0	SET SPG LOCK KET	鑰匙鎖固定彈簧	1	
		77232-GW0-3150-M2	0	LOCK ASSY FUEL LID	加油蓋鎖	1	
**		81131-KFA6-900	1	LEG SHIELD	行李箱	1	
**		81132-KFA6-900	0	LID LEG SHIELD	內箱蓋	1	
		81133-KBG-9000	0	STOPPER LUGGAGE	內箱襯蓋	1	
		81134-KFA6-9000	0	HOOK LUGGAGE	安全帽掛鉤	1	
		81135-KGBG-900	2	STAY LUGGAGE HOOK	掛鉤座	1	
**		81141-KFA6-900	0	LID INNER BOX	內箱蓋	1	
		81142-KFA6-9000	0	STAY LID INNER BOX	導線鉤支柱	2	
		81146-GN2-0010	0	SEAL RUBBER A	內箱防水封 A	1	
		90110-GW0-0010	0	SCREW SPECIAL 6*14	螺絲 6*14	1	
		90164-MR4-9010	0	SCREW SPECIAL 6MM	特殊螺絲 6MM	1	
		90301-634-6700	0	NUT FLANGE 6MM	螺帽 6MM	1	
		90302-GY6-9010	0	BOLT WASHER 5*12	螺絲 5*12	2	

F 5 Front Cover●Floor Panel

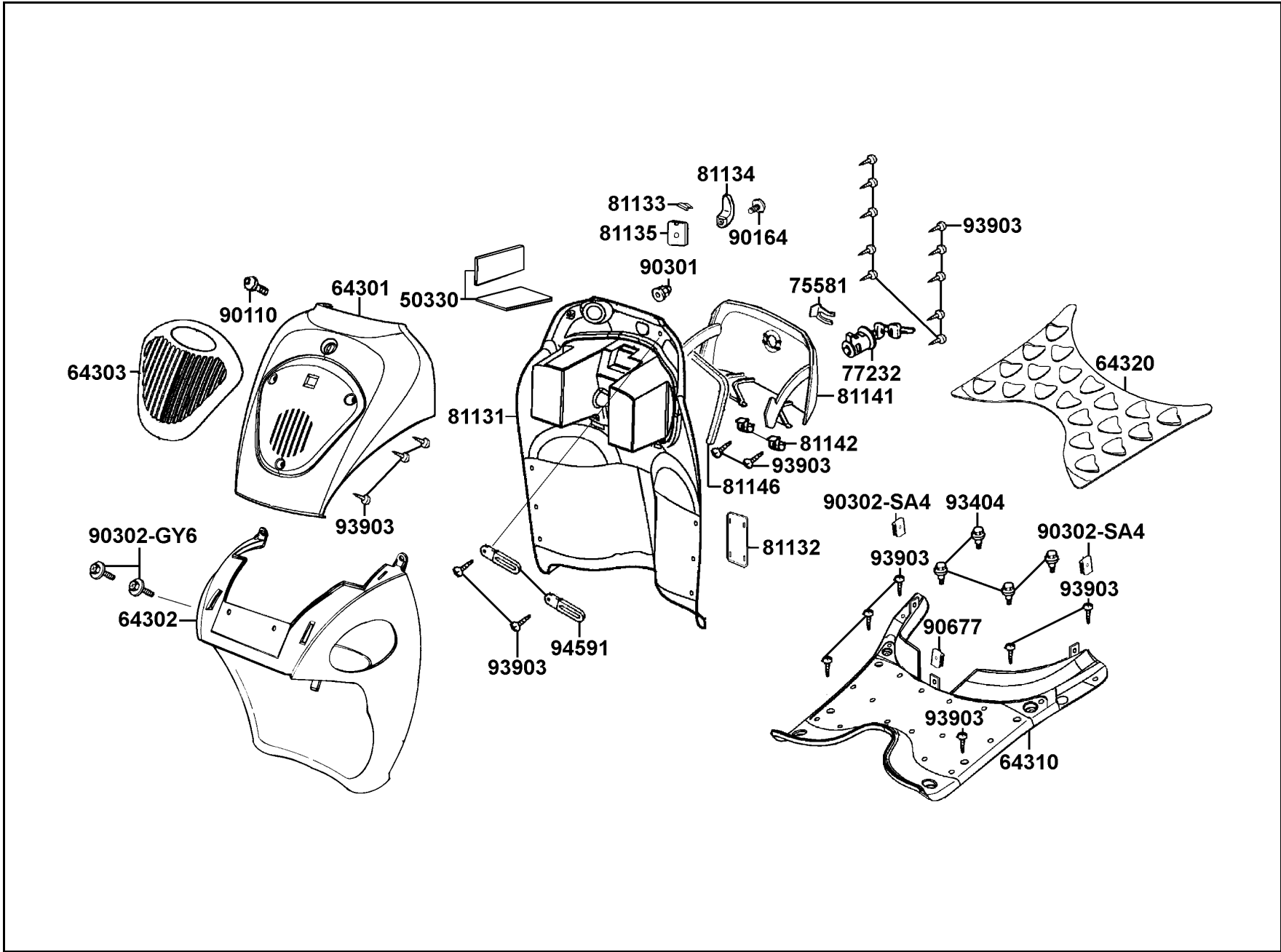

F 5

販賣記號	項目	零件號碼	版數	英文名稱	中文名稱	需要用量	參考價
Sales mark	Ref no	Part no	Ver	Description	Chinese	Regd no	Ref Price
		90302-SA4-0040	1	NUT SPRING 4MM	螺帽 4MM	2	
		90677-GR1-0030	1	NUT CLIP 5MM	彈簧螺帽 5MM	1	
		93404-06020-07	0	BOLT WASH 6*20	螺絲 6*20	4	
		93903-34380	0	SCREW TAPPING 4*12	螺絲 4*12	23	
		94591-27000	0	CLIP 2*70	夾 2*70	2	

F 6 Steering Stem ● Front Fork

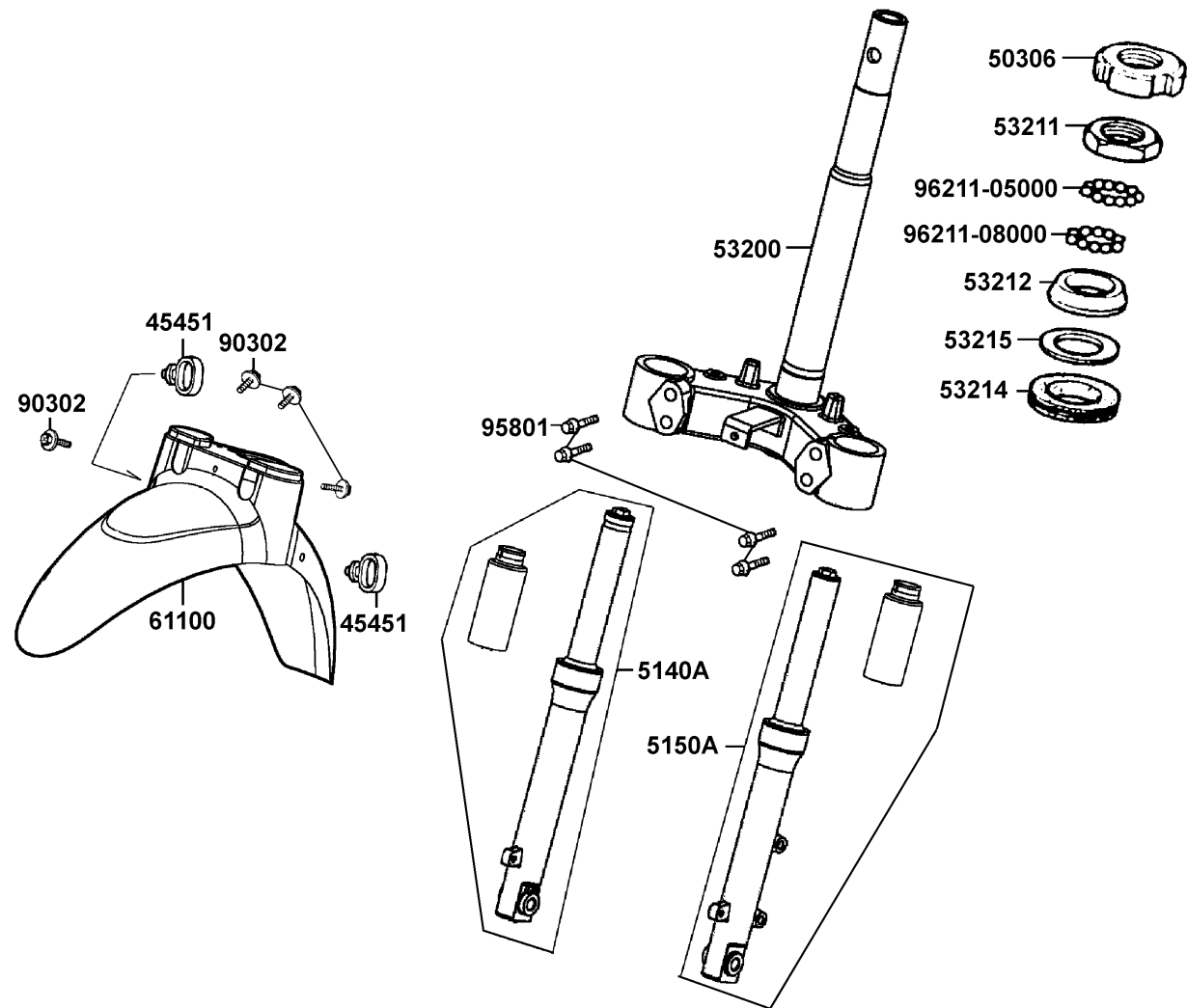

販賣記號	項目	零件號碼	版數	英文名稱	中文名稱	需要用量	參考價
Sales mark	Ref no	Part no	Ver	Description	Chinese	Regd no	Ref Price
		45451-471-0010	1	GROMMET WIRE	導線索環	2	
		50306-196-0010	0	NUT STRG STEM LOCK	主幹螺帽	1	
**		5140A-KFA6-E00	2	FORK SET R FR	右前避震器	1	
**		5150A-KFA6-E00	2	FORK SET L FR	左前避震器	1	
		53200-KFA6-9000	1	STEM COMP STRG	轉向桿	1	
		53211-GY6-9400	0	RACE STRG TOP CONE	上錐體座圈	1	
		53212-250-0110	0	RACE STRG BOT CONE	下錐體座圈	1	
		53214-250-0010	0	DUST SEAL STRG(HEAD)	墊片	1	
		53215-250-0010	0	WASH STRG HDL DUST-SEAL	轉向桿華司	1	
**		61100-KFA6-900	0	FENDER FR	前土除	1	
		90302-GY6-9400	0	BOLT WASH 5*16	螺絲 5*16	4	
		95801-08040-08	0	BOLT FLANGE 8*40	螺絲 8*40	4	
		96211-05000	0	BALL STEEL 5	鋼珠	26	
		96211-08000	0	BALL STEEL 8	鋼珠	19	

F 7 Front Wheel

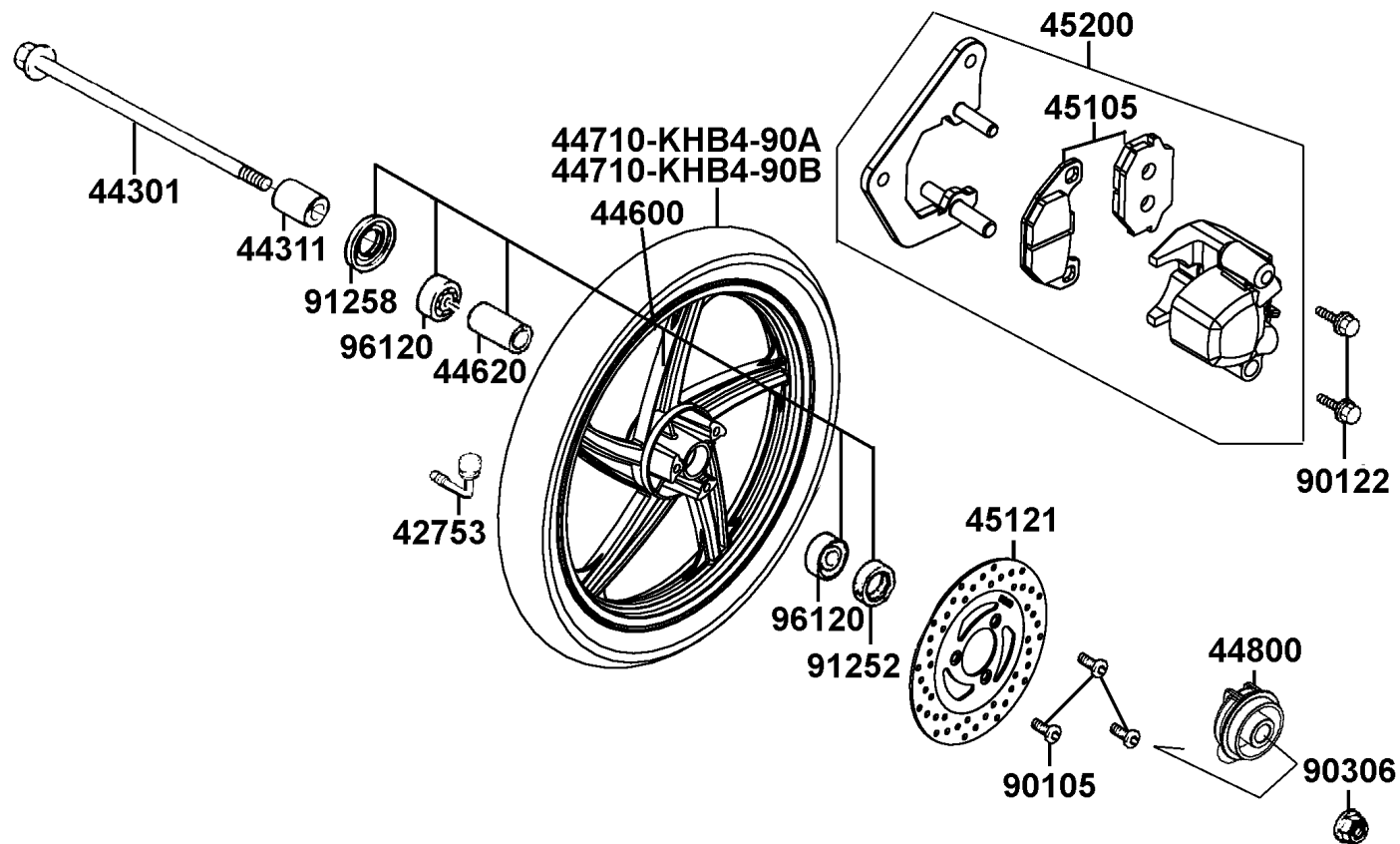

販賣記號	項目	零件號碼	版數	英文名稱	中文名稱	需要用量	參考價
Sales mark	Ref no	Part no	Ver	Description	Chinese	Regd no	Ref Price
		42753-KBN-9020-M2	0	VALVE RIM (TR 412)	打氣嘴	1	
		44301-KAA-900	4	AXLE FR WHEEL	前輪軸	1	
		44311-046-0010	0	COLLAR FR WHEEL SIDE	前輪邊套筒	1	
**		44600-KFA6-305	0	WHEEL SET FR	前輪圈組	1	
		44620-400-0000	1	COLLAR FR DIST	前輪軸距套筒	1	
		44710-KHB4-90A	0	TIRE ASSY FR	前輪胎	1	
		44710-KHB4-90B	0	TIRE ASSY FR	前輪胎	1	
		44800-KFA6-9000	0	GEAR BOX ASSY SPDMT	速度齒輪箱組	1	
		45105-KFA6-3050	0	PAD ASSY	煞車摩擦板組	1	
		45121-KFA6-9000	0	DISK FR BRAKE	前煞車圓盤	1	
**		45200-KFA6-900	2	CALIPER ASSY FR	前煞車卡鉗	1	
		90105-KR3-0010	1	BOLT FR DISK 8*24	前煞車圓盤螺絲 8*24	3	
		90122-KBE-9000	0	BOLT FLANGE 8*32	特殊螺絲 8*32	2	
		90306-KF0-901	0	NUT FLANGE 12MM	螺帽 12MM	1	
		91252-030-0000	0	OIL SEAL WHEEL 23*37*7	油封 23*37*7	1	
		91258-410-0000-M2	0	SEAL DUST 40*50*5	油封 40*50*5	1	
		96120-63010-10	0	BEARING BALL RADIAL 6301	軸承 6301	2	

F 8 Rear Wheel

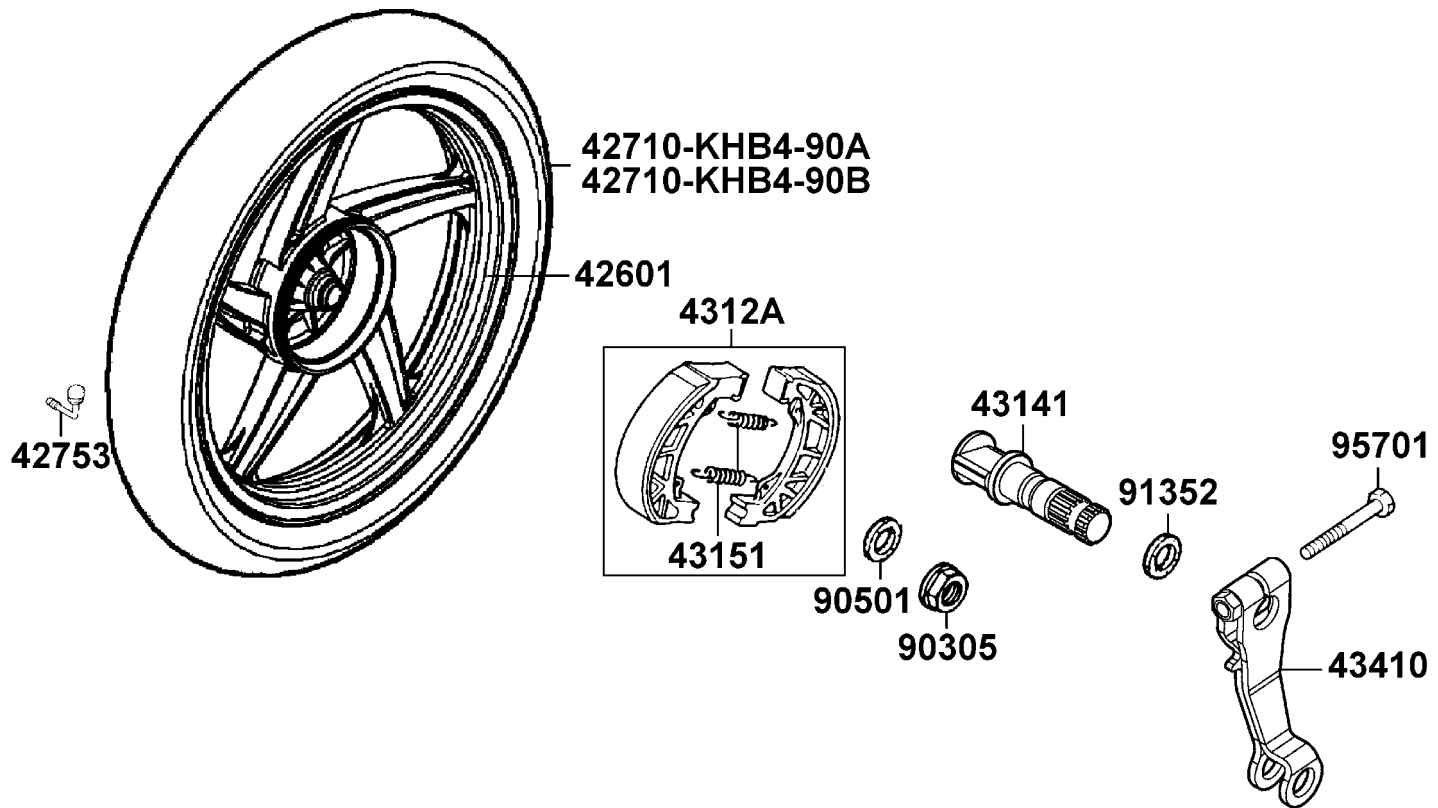

販賣記號	項目	零件號碼	版數	英文名稱	中文名稱	需要用量	參考價
Sales mark	Ref no	Part no	Ver	Description	Chinese	Regd no	Ref Price
**		42601-KFA6-900	1	WHEEL COMP RR CAST	後輪圈組	1	
		42710-KHB4-90A	0	TIRE ASSY RR	後輪胎	1	
		42710-KHB4-90B	0	TIRE ASSY RR	後輪胎	1	
		42753-KBN-9020-M2	0	VALVE RIM (TR 412)	打氣嘴	1	
		4312A-KDU-900	4	SHOE ASSY RR BRAKE	後煞車鞋組	1	
		43141-KFA6-9000	0	CAM RR BRK	後煞車凸輪	1	
		43151-KM7-9600	1	SPRING BRAKE SHOE	煞車鞋彈簧	2	
		43410-KFA6-9000	1	ARM COMP RR BRAKE	後煞車臂	1	
		90305-KBN-9030	0	NUT U 16MM	螺帽 16MM	1	
		90501-KBN-9010	0	WASHER 16MM	華司 16MM	1	
		91352-KG8-8330-M2	0	O-RING 11.3*1.3	O環 11.3*1.3	1	
		95701-06032-08	0	BOLT FLANGE 6*32	螺絲 6*32	1	

F 9 Seat

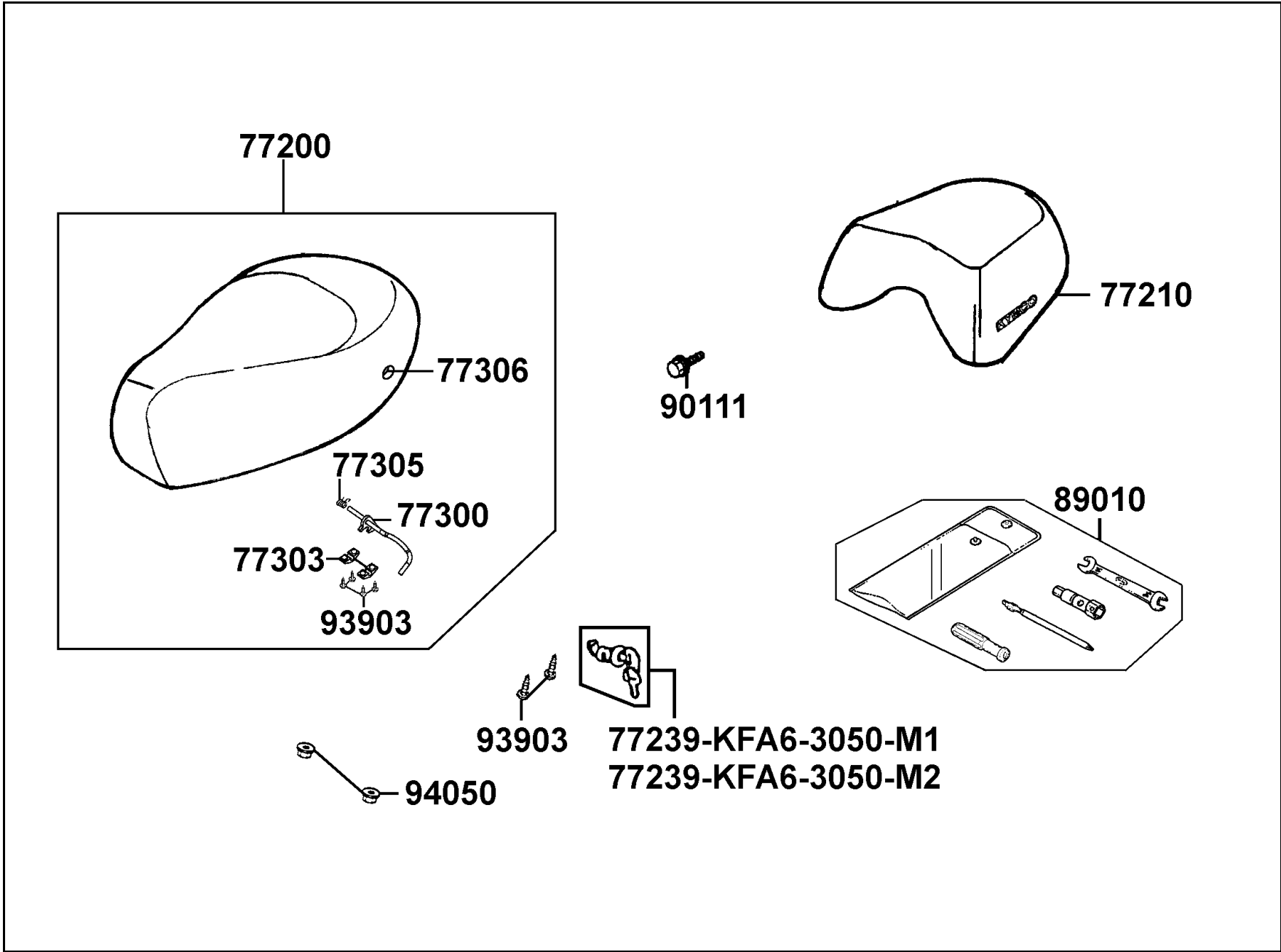

販賣記號	項目	零件號碼	版數	英文名稱	中文名稱	需要用量	參考價
Sales mark	Ref no	Part no	Ver	Description	Chinese	Regd no	Ref Price
**		77200-KFA6-900	0	SEAT ASSY	座墊	1	
**		77210-KFA6-900	0	SEAT ASSY REAR	後座墊	1	
		77239-KFA6-3050-M1	0	LOCK SET SEAT	座墊鎖組	1	
		77239-KFA6-3050-M2	0	LOCK SET SEAT	座墊鎖組	1	
		77300-KFA6-900	0	LOCK COMP SEAT	座墊鉤	1	
		77303-KFA6-9000	1	HOLDER HOOK BAR	座墊鉤固定座	2	
		77305-KFA6-9000	0	SPRING HOOK BAR	座墊鉤彈簧	1	
		77306-KFA6-900	0	COLLAR SEAT LOCK	座墊鎖套筒	1	
		89010-KBN-9000	0	TOOL SET	手工具組	1	
		90111-187-0000	1	BOLT FLANGE 6MM	螺絲 6MM	1	
		93903-34380	0	SCREW TAPPING 4*12	螺釘 4*12	6	
		94050-06080	0	NUT FLANGE 6MM	特殊螺帽 6MM	2	

F 10 Fuel Tank

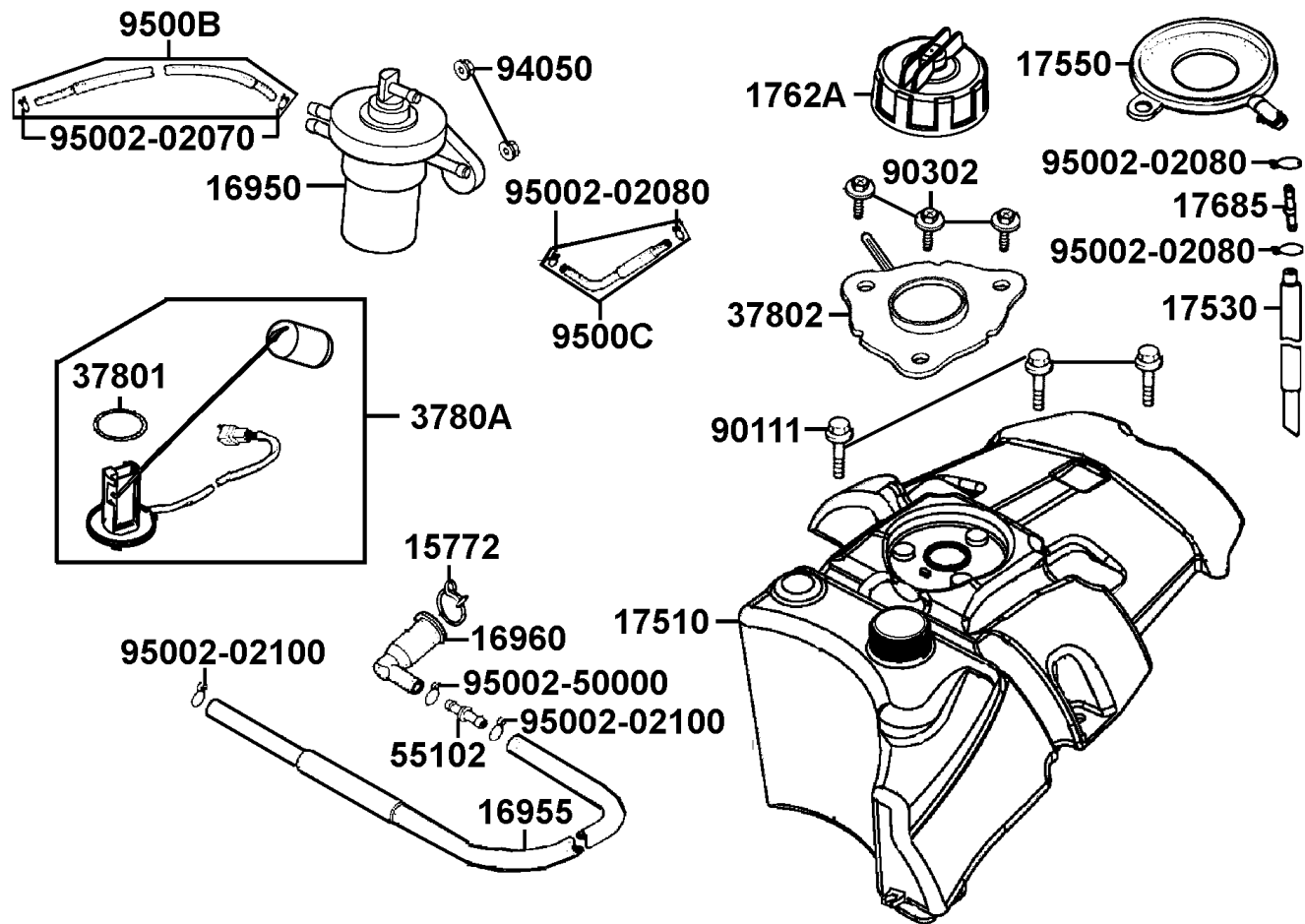

販賣記號	項目	零件號碼	版數	英文名稱	中文名稱	需要用量	參考價
Sales mark	Ref no	Part no	Ver	Description	Chinese	Regd no	Ref Price
		15772-551-0000	1	CLIP BRTHR TUBE	管夾	1	
		16950-KEC8-9000	3	AUTO COCK ASSY FUEL	自動油杯組	1	
		16955-KFA6-9000	0	TUBE ASSY FUEL	油管組	1	
		16960-KEC8-9000	0	TUBE FUEL STRN	濾油管接頭	1	
		17510-KFA6-800	6	TANK COMP FUEL	油箱	1	
		17530-KFA6-9000	0	TUBE ASSY FUEL DRAIN	油管	1	
		17550-KFA6-9000	0	TRAY FUEL CAP	油箱蓋托盤	1	
		1762A-KFA6-9000	3	CAP ASSY FUEL FILLER	油箱蓋	1	
		17685-KCZ-9000	0	JOINT TUBE	油管接頭	1	
		37802-KEC8-9000	0	RET FUEL UNIT	浮筒計承件	1	
		37801-GA7-7000	1	PACKING BASE	汽油量指示器墊圈	1	
		3780A-KFA6-9000	0	FUEL UNIT ASSY	燃料量指示器組	1	
		55102-166-0010	0	JOINT OIL TUBE	油管接頭	1	
		90111-187-0000	1	BOLT FLANGE 6MM	螺絲 6*14	3	
		90302-GY6-9010	0	BOLT WASH 5*12	螺絲 5*12	3	
		94050-06080	0	NUT FLANGE 6MM	螺帽 6MM	2	
		95002-02070	0	CLIP B7 TUBE	管夾	2	
		95002-02080	0	CLIP B8 TUBE	管夾	4	
		95002-02100	0	CLIP B10 TUBE	管夾	2	
		95002-50000	0	CLIP C9 TUBE	管夾	1	

F 10 Fuel Tank

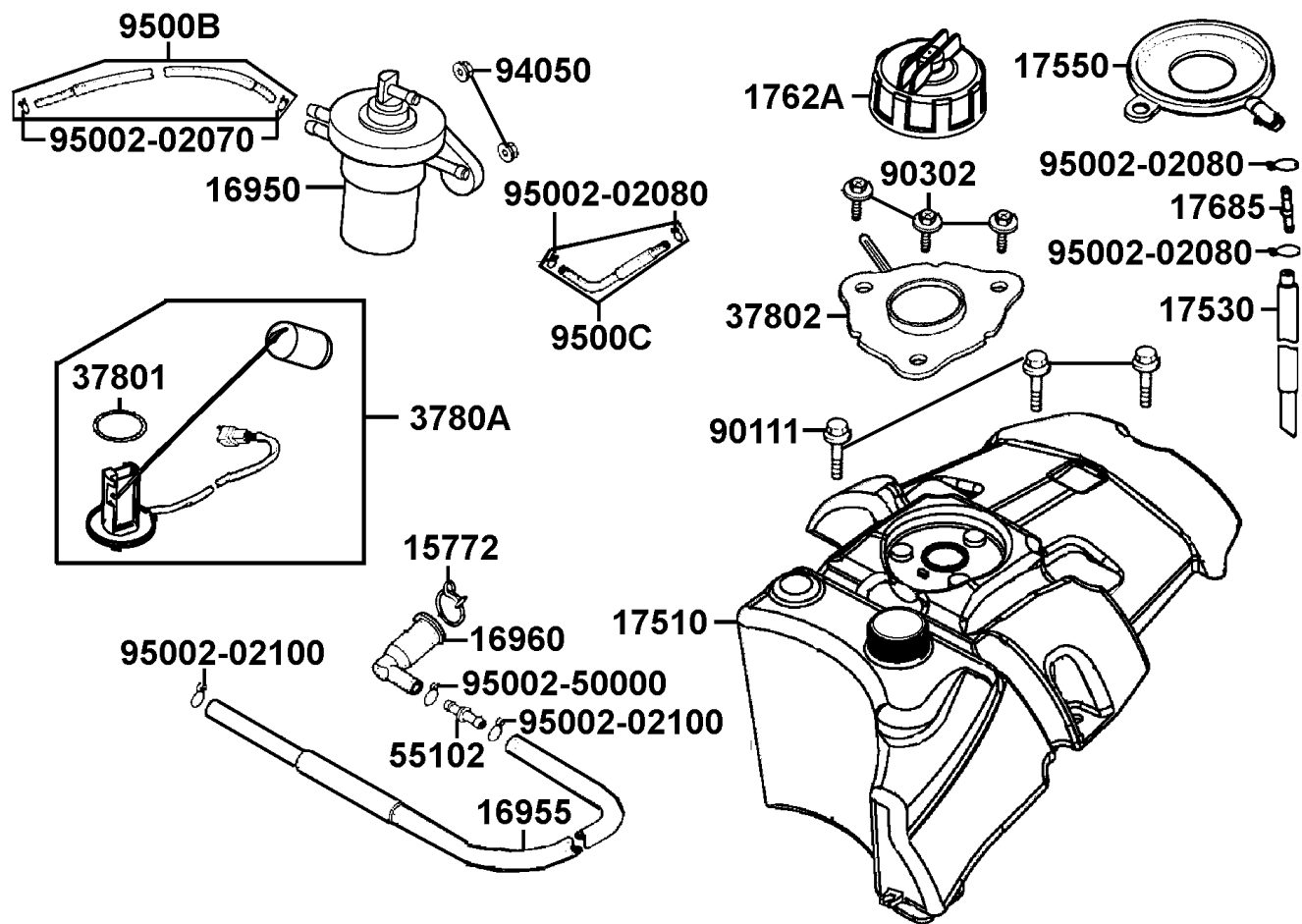

販賣記號	項目	零件號碼	版數	英文名稱	中文名稱	需要用量	參考價
Sales mark	Ref no	Part no	Ver	Description	Chinese	Regd no	Ref Price
		9500B-KFA6-9000	0	TUBE ASSY VACUUM	真空管組	1	
		9500C-KFA6-9000	0	TUBE ASSY FUEL	油管組	1	

F 11 Battery

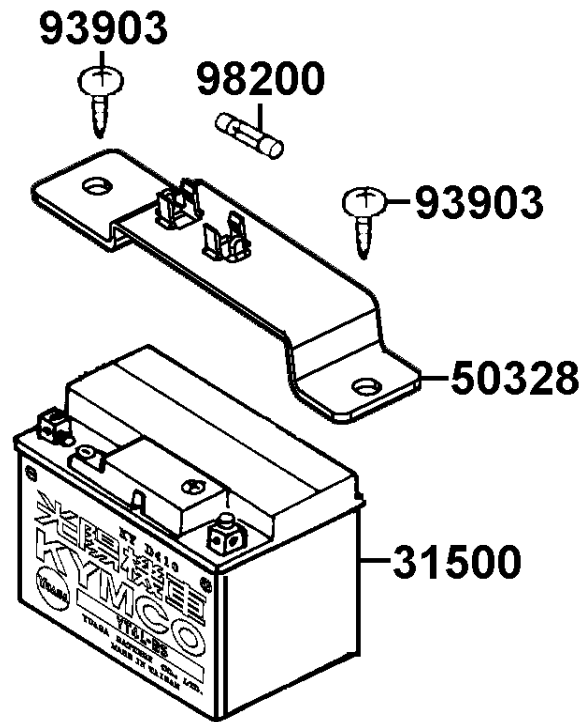

販賣記號	項目	零件號碼	版數	英文名稱	中文名稱	需要用量	參考價
Sales mark	Ref no	Part no	Ver	Description	Chinese	Regd no	Ref Price
		31500-KBN-9210-M1	3	BATTERY YTX5L-BS	電瓶	1	
		50328-KFA6-9000	0	BAND BATTERY	電瓶束帶	1	
		93903-35380	0	SCREW TAPPING 5*16	螺絲 5*16	2	
		98200-10700	0	FUSE A7	保險絲	1	

F 11

F 12 Oil Tank

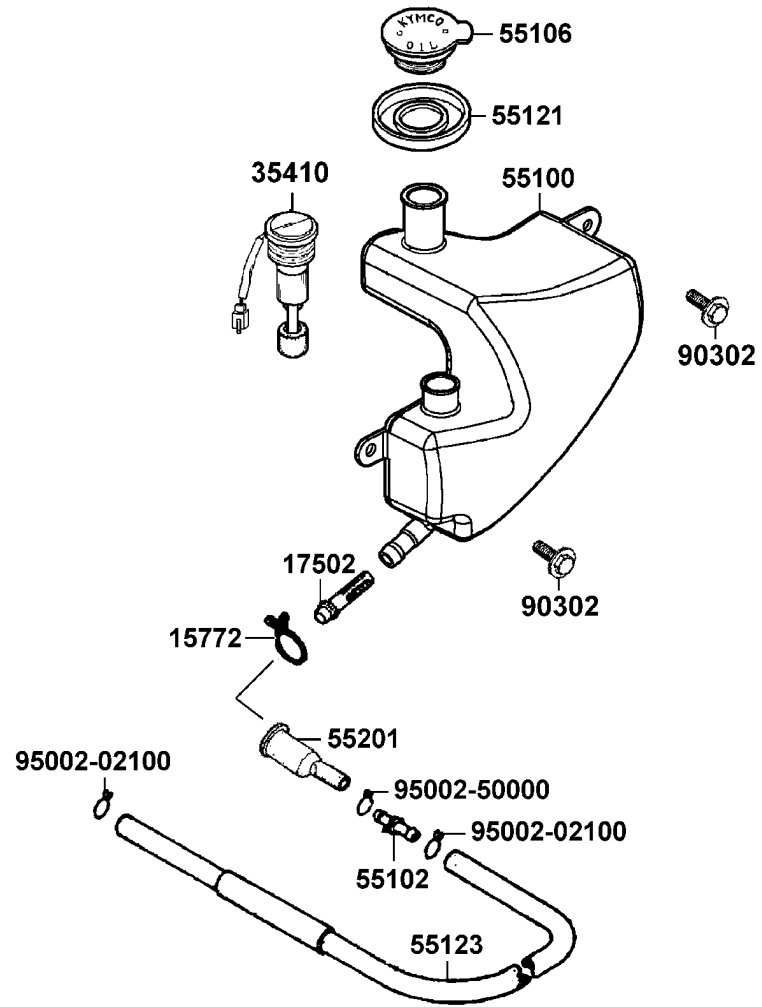

販賣記號	項目	零件號碼	版數	英文名稱	中文名稱	需要用量	參考價
Sales mark	Ref no	Part no	Ver	Description	Chinese	Regd no	Ref Price
		15772-551-0000	1	CLIP BREATHER TUBE	通氣管夾	1	
		17502-187-0000	0	OIL STRAINER	濾油器	1	
		35410-KEB7-9000	0	SW COMP OIL LEVEL	機油量指示器	1	
		55100-KFA6-9000	0	TANK OIL	機油箱	1	
		55102-166-0010	0	JOINT OIL TUBE	油管接頭	1	
		55106-KEB7-9000	2	CAP TANK OIL	機油箱蓋	1	
		55121-KEB7-9000	0	RUBBER OIL GUIDE	油箱托蓋	1	
		55123-KBN-9010	0	TUBE ϕ 5.3 OIL	油管	1	
		55201-GC8-0010	0	JOINT OIL STRN	濾油管接頭	1	
		90302-GY6-9010	0	BOLT WASHER 5*12	螺絲 5*12	2	
		95002-02100	0	CLIP B10 TUBE	管夾	2	
		95002-50000	0	CLIP C9 TUBE	管夾	1	

F 13 Body Cover●Luggage Box

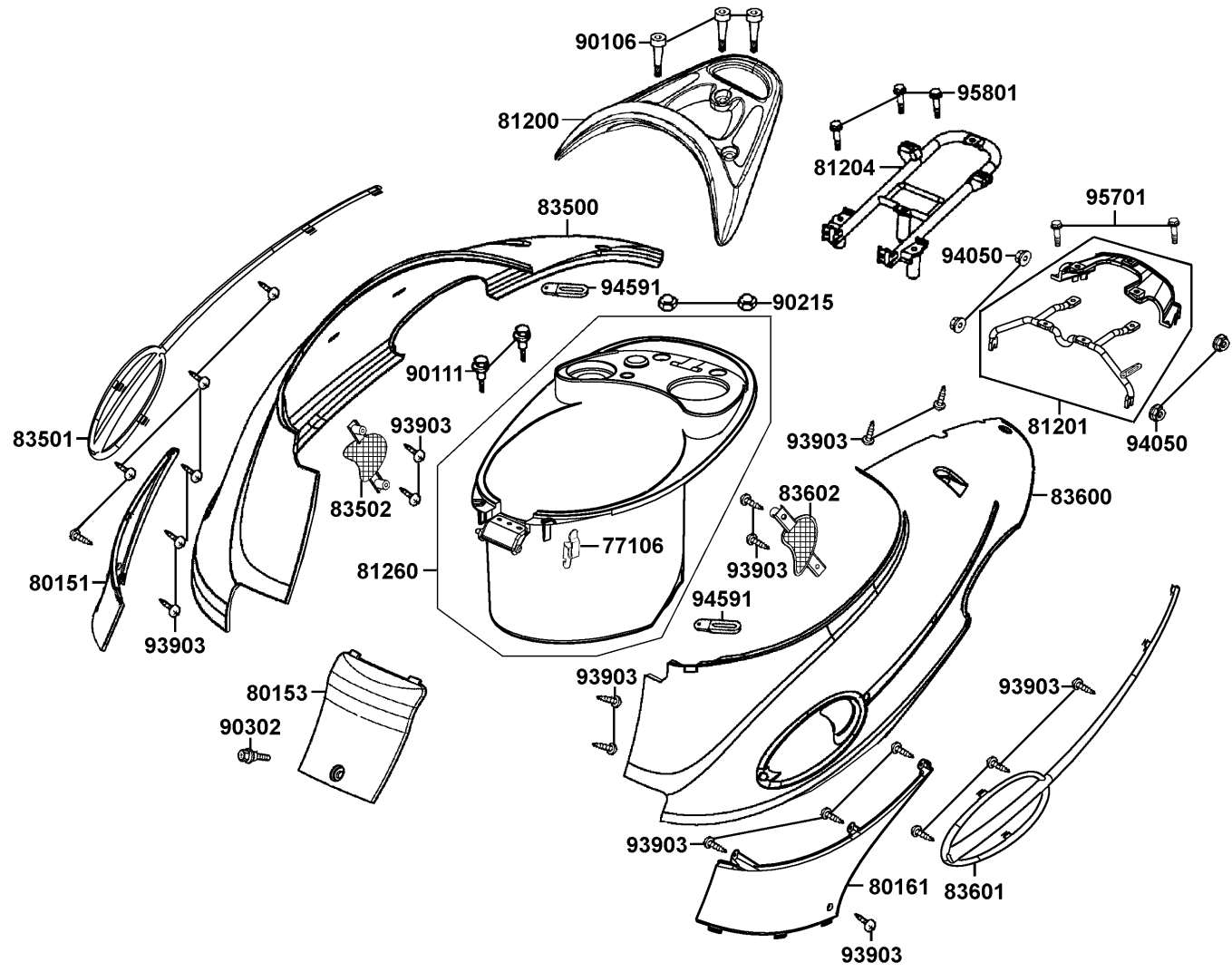

販賣記號	項目	零件號碼	版數	英文名稱	中文名稱	需要用量	參考價
Sales mark	Ref no	Part no	Ver	Description	Chinese	Regd no	Ref Price
		77106-KEB7-9000	0	HOOK HELMENT	安全帽掛	1	
**		80151-KFA6-900	0	COVER R CENTER	右中心蓋	1	
**		80153-KFA6-900	0	COVER PLUG MAINT	化油器護蓋	1	
**		80161-KFA6-900	0	COVER L CENTER	左中心蓋	1	
**		81200-KFA6-900	0	CARRIER REAR	後架	1	
		81201-KFA6-9000	1	BRKT COMP RR CARRIER	後架支座	1	
		81204-KFA6-9000	0	BRKT COMP RR CARRIER	後架座	1	
		81260-KFA6-E00	0	BOX ASSY LUGGAGE	行李箱	1	
**		83500-KFA6-900	2	COVER R BODY	車體右邊蓋	1	
		83501-KFA6-9000	0	EDGING R BODY COVER	右邊蓋飾條	1	
		83502-KFA6-9000	0	GRILL R BODY COVER	右邊蓋通氣孔	1	
**		83600-KFA6-900	2	COVER SET L BODY	車體左邊蓋	1	
		83601-KFA6-9000	0	EDGING L BODY COVER	左邊蓋飾條	1	
		83602-KFA6-9000	0	GRILL L BODY COVER	左邊蓋通氣孔	1	
		90106-KDU-9000	1	BOLT SPECIAL 8MM	螺絲 8MM	3	
		90111-KW6-0010	0	BOLT FLANGE 6MM	螺絲 6MM	2	
		90215-GM0-9100	0	NUT CAP 6MM	圓螺帽 6MM	2	
		90302-KED5-9000	1	BOLT PAN 5*9	螺絲 5*9	1	
		93903-34380	0	SCREW TAPPING 4*12	螺絲 4*12	22	
		94050-06080	0	NUT FLANGE 6MM	螺帽 6MM	4	

販賣記號	項目	零件號碼	版數	英文名稱	中文名稱	需要用量	參考價
Sales mark	Ref no	Part no	Ver	Description	Chinese	Regd no	Ref Price
		94591-27000	0	CLIP 2*70	管夾 2*70	2	
		95701-06016-08	0	SCREW SPECIAL 6*16	螺絲 6*16	2	
		95801-08065-07	0	BOLT FLANGE 8*65	螺絲 8*65	3	

F 14 Air Cleaner

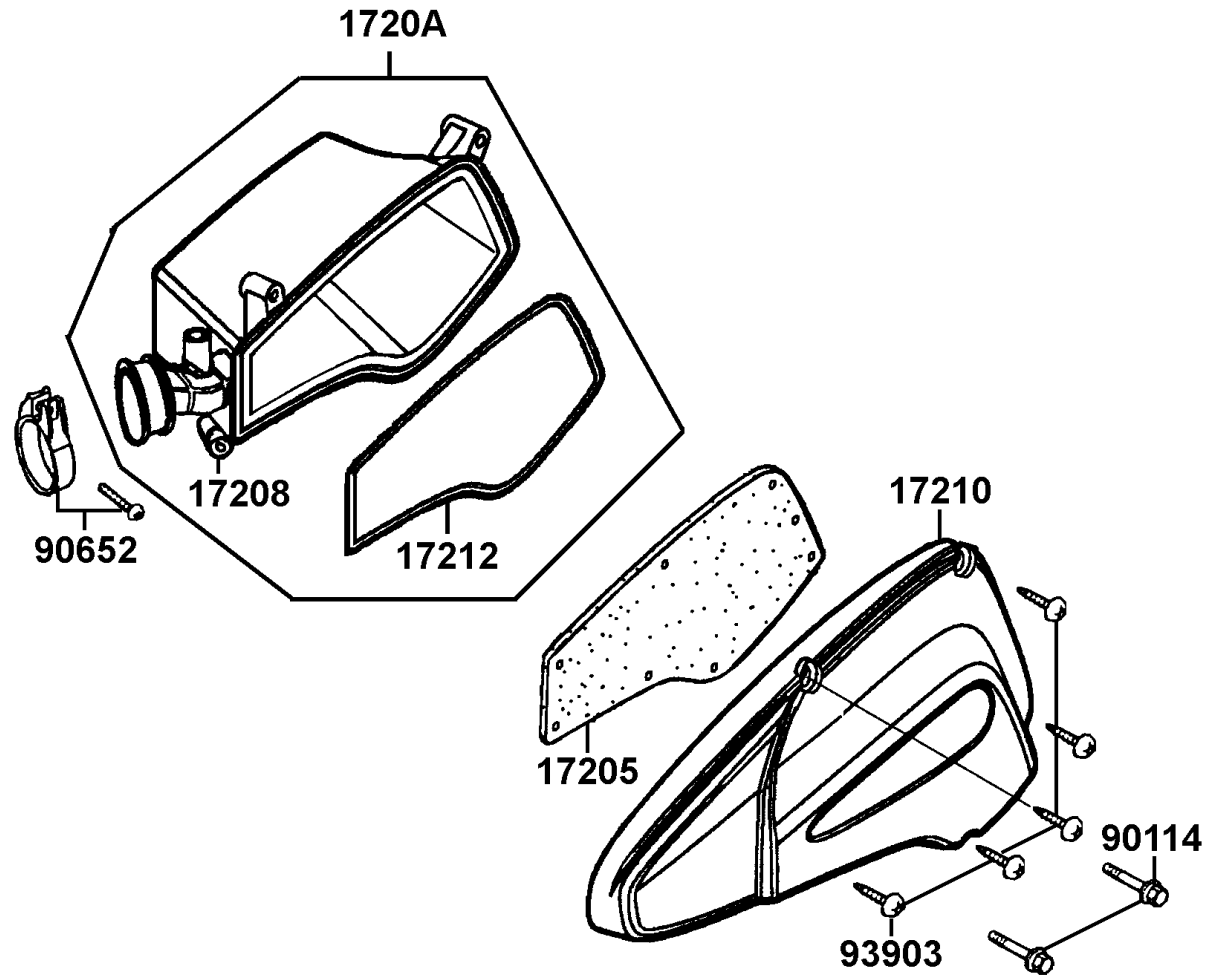

販賣記號	項目	零件號碼	版數	英文名稱	中文名稱	需要用量	參考價
Sales mark	Ref no	Part no	Ver	Description	Chinese	Regd no	Ref Price
		17205-KFA6-9000	0	ELEMENT AIR/C	空氣濾清器海綿	1	
		17208-GR1-0110	0	COLLAR AIR/C SET	套筒	2	
		1720A-KFA6-E00	0	CASE ASSY AIR/C	空氣濾清器箱組	1	
		17210-KFA6-9000	0	COVER COMP AIR/C	空氣濾清器蓋	1	
		17212-KFA6-9000	0	SEAL AIR/C COVER	空氣濾清箱蓋防塵封	1	
		90114-GM4-0110	1	BOLT FLANGE SH 6*28	螺絲 6*28	2	
		90652-KCT-9000	0	BAND AIR/C CONN TUBE	連接管固定帶	1	
		93903-25480	0	SCREW TAPPING 5*20	螺釘 5*20	5	

F 15 Exhaust Muffler

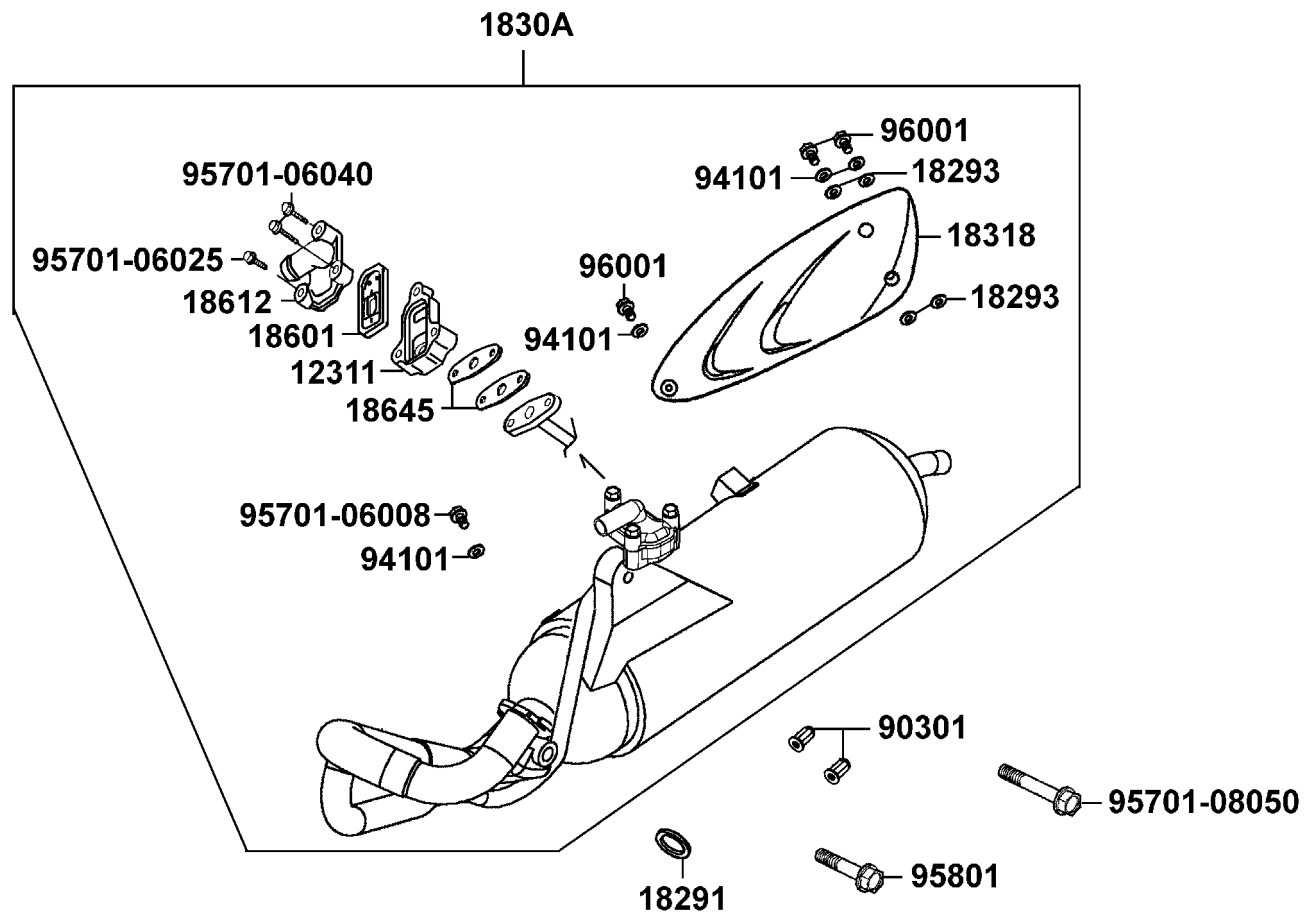

販賣記號	項目	零件號碼	版數	英文名稱	中文名稱	需要用量	參考價
Sales mark	Ref no	Part no	Ver	Description	Chinese	Regd no	Ref Price
		12311-KFB5-900	2	BODY REED VALVE	單向閥本體座	1	
		18291-166-0040	0	GASKET EXH PIPE	排氣管墊圈	1	
		18293-GY6-9000	0	PACKING PROTECTOR	護板墊熱片	4	
		1830A-KFA6-E05	0	MUFFLER ASSY EXH	排氣管組	1	
		18318-KAF-E000	0	PROTECTOR MUFFLER	排氣管護蓋	1	
		18601-KFB5-9000	0	VALVE COMP REED	簧片彈簧閥	1	
		18612-KFB5-9000	0	COVER REED VALVE	簧片單向閥蓋	1	
		18645-KGB5-EZ0	1	GASKET A/I PIPE	通氣鐵管墊片	2	
		90301-KGBG-9000	0	NUT CAP 6MM	圓螺帽	2	
		94101-06700	0	WASHER PLAIN 6MM	平華司 6MM	4	
		95701-06008-07	0	BOLT FLANGE 6*8	螺絲 6*8	1	
		95701-06025-08	0	BOLT FLANGE 6*25	螺絲 6*25	1	
		95701-06040-08	0	BOLT FLANGE 6*40	螺絲 6*40	2	
		95701-08050-07	0	BOLT FLANGE 8*50	螺絲 8*50	1	
		95801-KFA6-E000	0	BOLT TORX 8*35	防改裝螺絲 8*35	1	
		96001-06012-08	0	BOLT FLANGE SH 6*12	螺絲 6*12	3	

販賣記號	項目	零件號碼	版數	英文名稱	中文名稱	需要用量	參考價
Sales mark	Ref no	Part no	Ver	Description	Chinese	Regd no	Ref Price
		28300-KFA6-9000	1	ARM ASSY KICK STARTER	起動踏桿組	1	
		50503-KEB7-9000	1	SHAFT MAIN STAND	主腳架軸	1	
		50505-KKD7-9000	0	STOPPER RUBBER	主腳架橡皮	1	
		5050A-KFA6-900	3	STAND ASSY MAIN	主腳架	1	
		50527-KED5-9000	0	BUSH OILES	套筒	2	
		50530-KFA6-E000	1	BAR SIDE STAND	側腳架	1	
		50531-KEB7-E000	1	PLATE SPRING STOPPER	彈簧止住板	1	
		50535-KEB7-E000	1	SPRING COMP SIDE STAND	側腳架彈簧	1	
		50550-KFA6-E00	0	SPG ASSY MAIN STAND	主腳架彈簧	1	
		90108-KFA6-E000	0	SCREW SIDE STAND PIVOT	側腳架螺絲	1	
		94101-08700	0	WASHER PLAIN 8MM	華司 8MM	1	
		94251-08400	0	PIN LOCK 8MM	插銷 8MM	1	
		96700-KFA6-9000	0	SOCKET BOLT 6*20	螺絲 6*20	1	

F 17 Rear Cushion

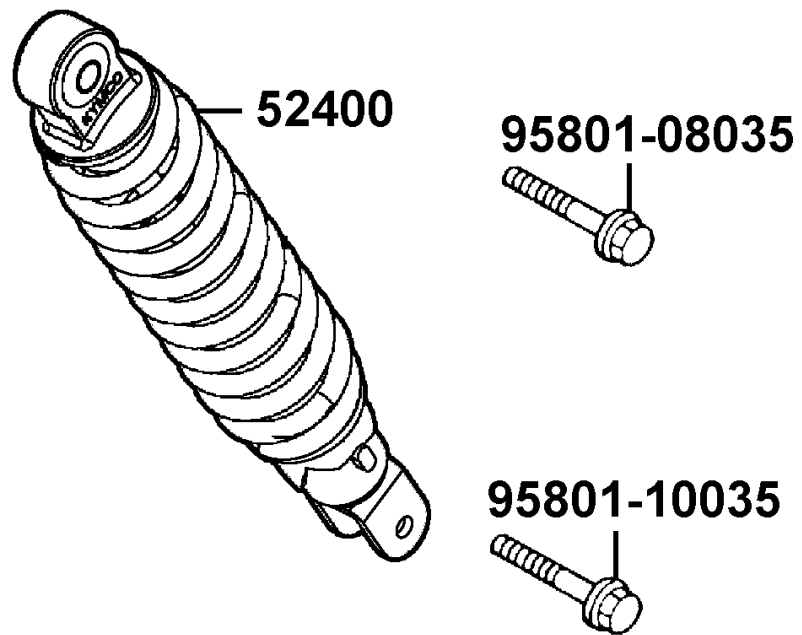

販賣記號	項目	零件號碼	版數	英文名稱	中文名稱	需要用量	參考價
Sales mark	Ref no	Part no	Ver	Description	Chinese	Regd no	Ref Price
		52400-KFA6-E000	1	CUSHION ASSY RR	後緩衝器組	1	
		95801-08035-08	0	BOLT FLANGE 8*35	螺絲 8*35	1	
		95801-10035-08	0	BOLT FLANGE 10*35	螺絲 10*35	1	

F 18 Winker

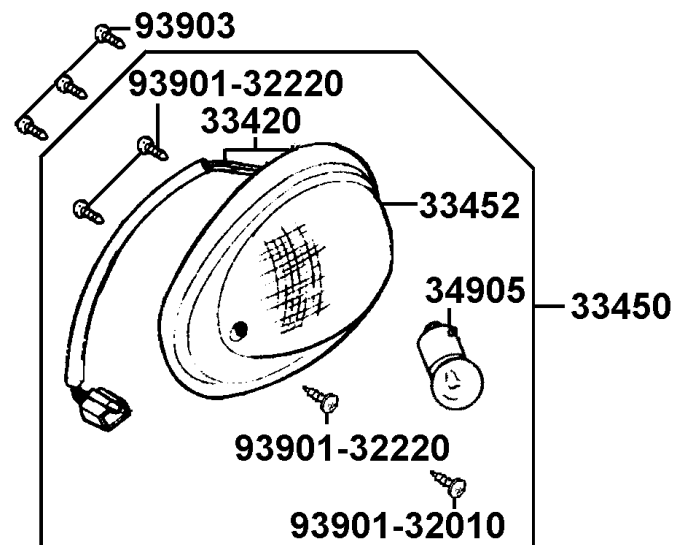
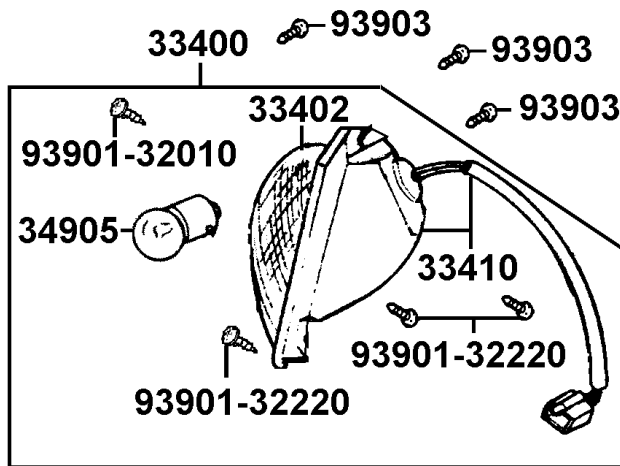
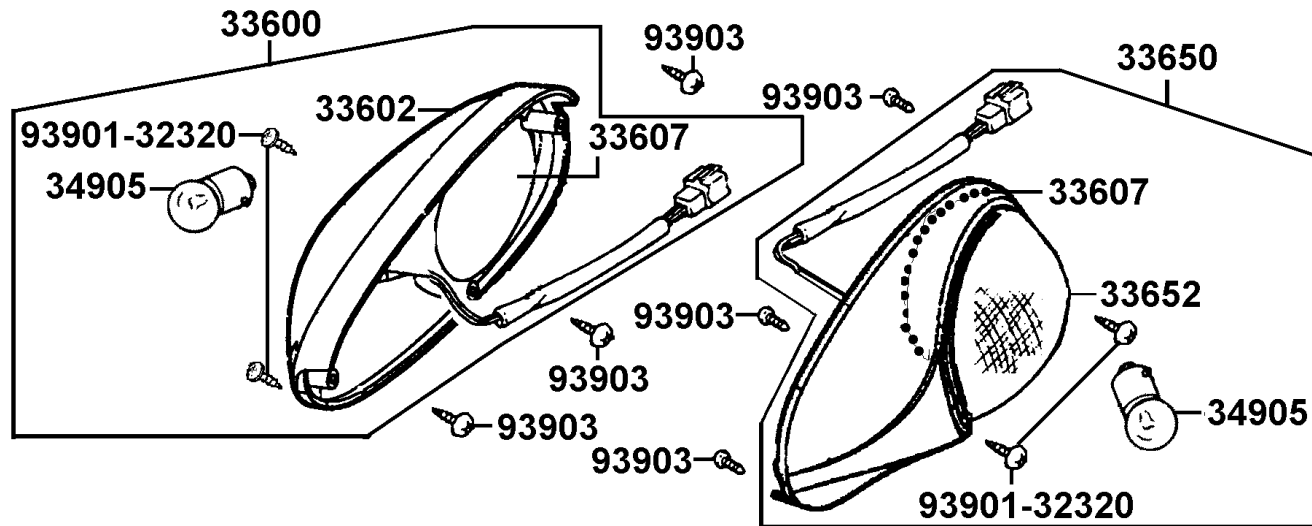

販賣記號	項目	零件號碼	版數	英文名稱	中文名稱	需要用量	參考價
Sales mark	Ref no	Part no	Ver	Description	Chinese	Regd no	Ref Price
		33400-KFA6-E200	0	WINKER ASSY R FR	右前方向燈組	1	
		33402-KFA6-9100	0	LENS R FR WINKER	右前方向燈殼	1	
		33410-KFA6-9100	0	BASE COMP R FR WINKER	右前方向燈座	1	
		33420-KFA6-9100	0	BASE COMP L FR WINKER	左前方向燈座	1	
		33450-KFA6-E200	0	WINKER ASSY L FR	左前方向燈組	1	
		33452-KFA6-9100	0	LENS L FR WINKER	左前方向燈殼	1	
		33600-KFA6-E000	2	LIGHT R RR WINKER	右後方向燈組	1	
		33602-KFA6-E000	0	LENS R FR WINKER	右後方向燈殼	1	
		33607-KFA6-E00	0	COVER RUBBER	方向燈配線橡皮套蓋	2	
		33650-KFA6-E000	2	WINKER ASSY L RR	左後方向燈組	1	
		33652-KFA6-E000	0	LENS L FR WINKER	左後方向燈殼	1	
		34905-KCP-9000	0	BULB WINKER	方向燈燈泡	4	
		93901-32010	0	SCREW TAPPING 3*6	螺釘 3*6	2	
		93901-32220	0	SCREW TAPPING 3*10	螺釘 3*10	6	
		93901-32320	0	SCREW TAPPING 3*12	螺釘 3*12	4	
		93903-34380	0	SCREW TAPPING 4*12	螺絲 4*12	12	

F 19 Tail Light

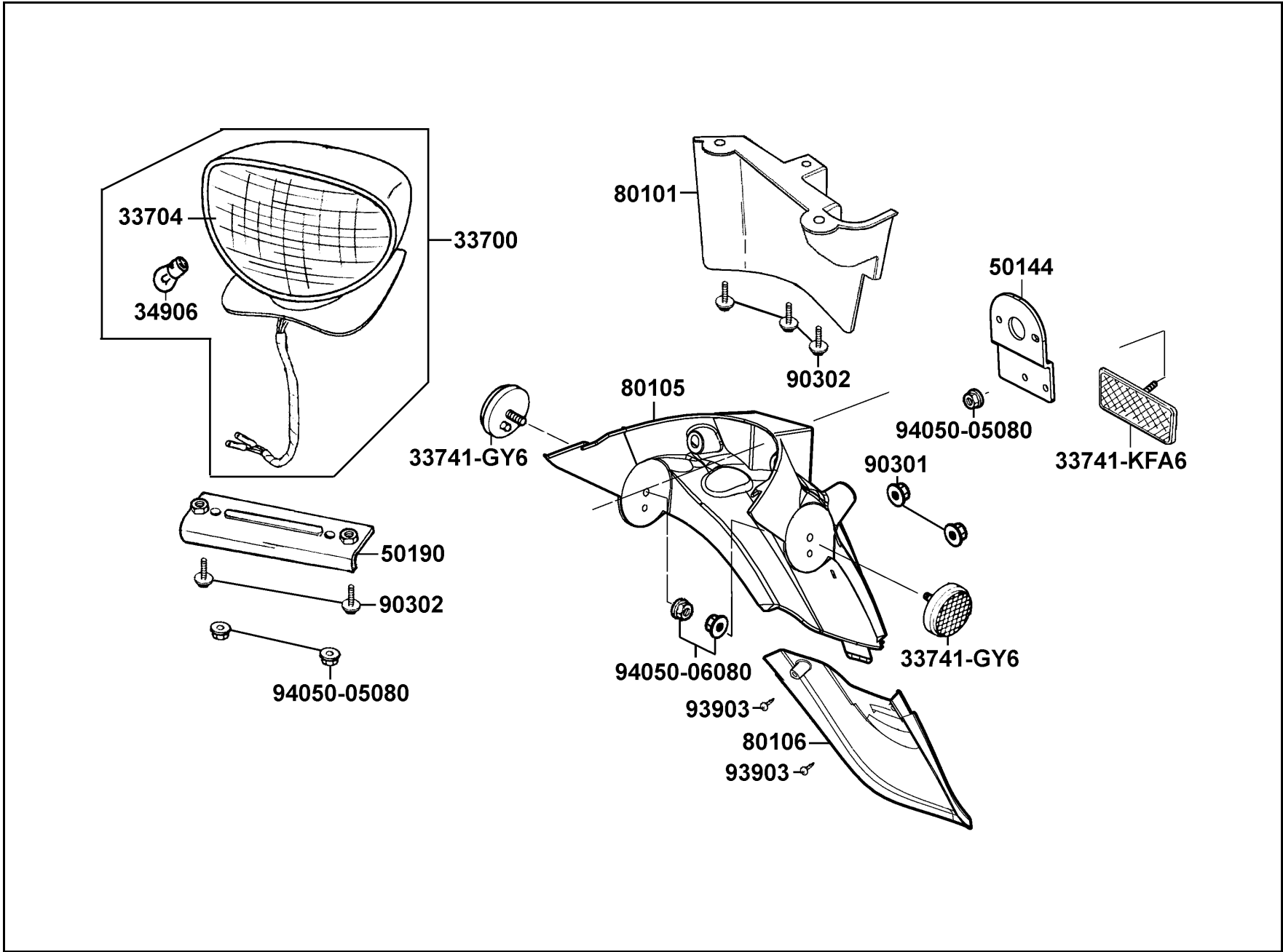

販賣記號 Sales mark	項目 Ref no	零件號碼 Part no	版數 Ver	英文名稱 Description	中文名稱 Chinese	需要用量 Regd no	參考價 Ref Price
		33700-KFA6-E000	1	LIGHT ASSY TAIL	後燈組	1	
		33704-KFA6-9000	0	LENS COMP TAIL LIGHT	後燈殼	1	
		33741-GY6-C300	1	REFLEX REFLECTOR	反光鏡片	2	
		33741-KFA6-9000	0	REFLEX REFLECTOR	反光鏡片	1	
		34906-KCP-9000	0	BULB TAIL & STOP	後燈燈泡	1	
		50190-KFA6-9000	0	STAY LIGHT TAIL	後燈座	1	
		80101-KFA6-9000	0	FENDER A RR	後土除 A	1	
		80105-KFA6-900	1	FENDER REAR	後土除	1	
		80106-KFA6-9000	0	FENDER LOW REAR	後下土除	1	
		90301-634-6700	0	NUT FLANGE 6MM	螺帽 6MM	2	
		90302-GY6-9010	0	BOLT WASHER 5*12	螺絲 5*12	5	
		93903-34380	0	SCREW TAPPING 4*12	螺絲 4*12	2	
		94050-05080	0	NUT FLANGE 5MM	螺帽 5MM	3	
		94050-06080	0	NUT FLANGE 6MM	螺帽 6MM	2	

F 20 Wire Harness

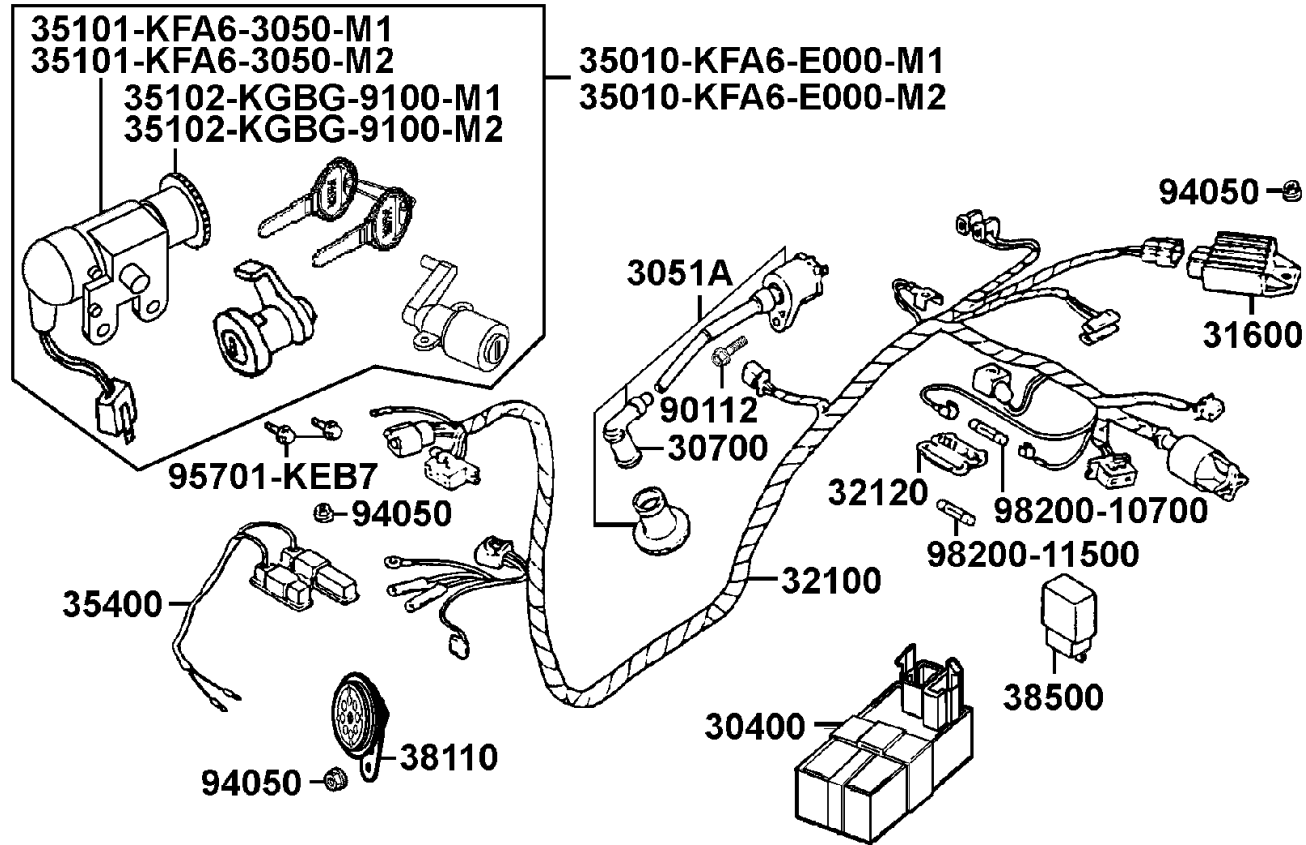

販賣記號	項目	零件號碼	版數	英文名稱	中文名稱	需要用量	參考價
Sales mark	Ref no	Part no	Ver	Description	Chinese	Regd no	Ref Price
		30400-KFA6-E0A	3	CDI SPEED CONTROL ASSY	限速C. D. I組	1	
		3051A-KFA6-9000-M2	1	COIL ASSY IGN	點火線圈	1	
		30700-KBN-9010	2	CAP ASSY NOISE SUPPR	火星塞蓋	1	
		31600-KDU-9000	0	REG REC COMP	整流器	1	
		32100-KFA6-900	4	HARNESS WIRE	主配線	1	
		32120-155-0010	0	CASE FUSE	保險絲盒	1	
		35010-KFA6-E000-M1	1	KEY SET	開關組	1	
		35010-KFA6-E000-M2	1	KEY SET	開關組	1	
		35101-KFA6-3050-M1	0	SW COMB & LOCK	主開關組	1	
		35101-KFA6-3050-M2	0	SW COMB & LOCK	主開關組	1	
		35102-KGBG-9100-M1	0	COLLAR MAIN SW	主開關指示器套筒	1	
		35102-KGBG-9100-M2	0	COLLAR MAIN SW	主開關指示器套筒	1	
		35400-KBN-9200	0	RESISTOR COMP	電阻器組	1	
		38110-GS7-E000-M1	2	HORN COMP	喇叭	1	
		38500-KFA6-9000	0	RELAY ASSY START	啟動繼電器	1	
		90112-KDR-9000	0	BOLT FLANGE 5*22	螺絲 5*22	1	
		94050-06080	0	NUT FLANGE 6MM	螺帽 6MM	3	
		95701-KEB7-E000	1	BOLT FLANGE 6*16	螺絲 6*16	2	
		98200-10700	0	FUSE A7	保險絲 A7	1	
		98200-11500	0	FUSE A15	保險絲 A15	1	

F 21 Frame Body

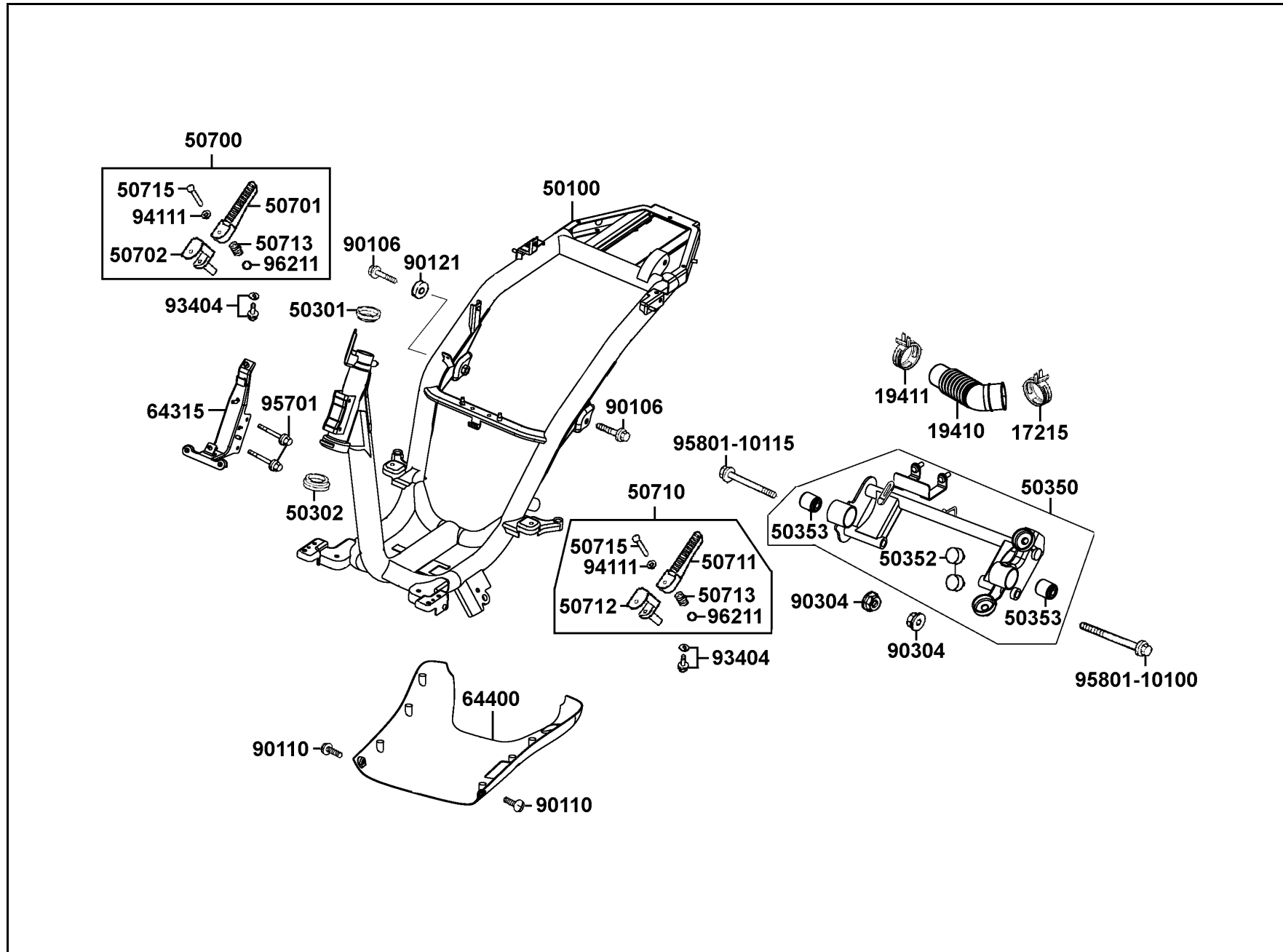

販賣記號	項目	零件號碼	版數	英文名稱	中文名稱	需要用量	參考價
Sales mark	Ref no	Part no	Ver	Description	Chinese	Regd no	Ref Price
		17215-KBN-2000	0	CLIP ASSY AIR/C DUCT	管夾	1	
		19410-KFA6-9000	0	HOSE COOLING	冷卻管	1	
		19411-KBN-9000	1	CLIP HOSE	管夾	1	
		50100-KFA6-E05	3	BODY COMP FRAME	車體	1	
		50301-KN7-6710	2	RACE UPPER STRG BALL	上珠碗	1	
		50302-268-0110	0	RACE UNDER STRG BALL	下珠碗	1	
		50350-KFA6-9000	0	HANGER ASSY ENG	引擎吊架組	1	
		50352-KFA6-9000	0	STOPPER RUBBER	制止橡皮	2	
		50353-GG2-7110	1	BUSH SWING LOCK	襯套	2	
		50700-KFA6-9000	2	BAR ASSY R REAR STEP	右後踏板組	1	
		50701-KFA6-9000	2	BAR R REAR STEP	後座右踏桿	1	
		50702-KFA6-9000	2	STAY R PILLION STEP	後座右踏桿托架	1	
		50710-KFA6-9000	2	BAR ASSY L REAR STEP	左後踏板組	1	
		50711-KFA6-9000	2	BAR L REAR STEP	後座右踏桿	1	
		50712-KFA6-9000	2	STAY L PILLION STEP	後座右踏桿托架	1	
		50713-KEB7-9000	0	SPRING	彈簧	2	
		50715-KFA6-9000	0	PIN REAR STEP	後座右踏桿插銷	2	
		64315-KFA6-9000	0	STAY FR COVER	前護蓋支柱	1	
**		64400-KFA6-900	0	COWL UNDER	下罩	1	
		90106-GY6-9010	0	BOLT FLANGE 10*55	螺絲 10*55	2	

F 21 Frame Body

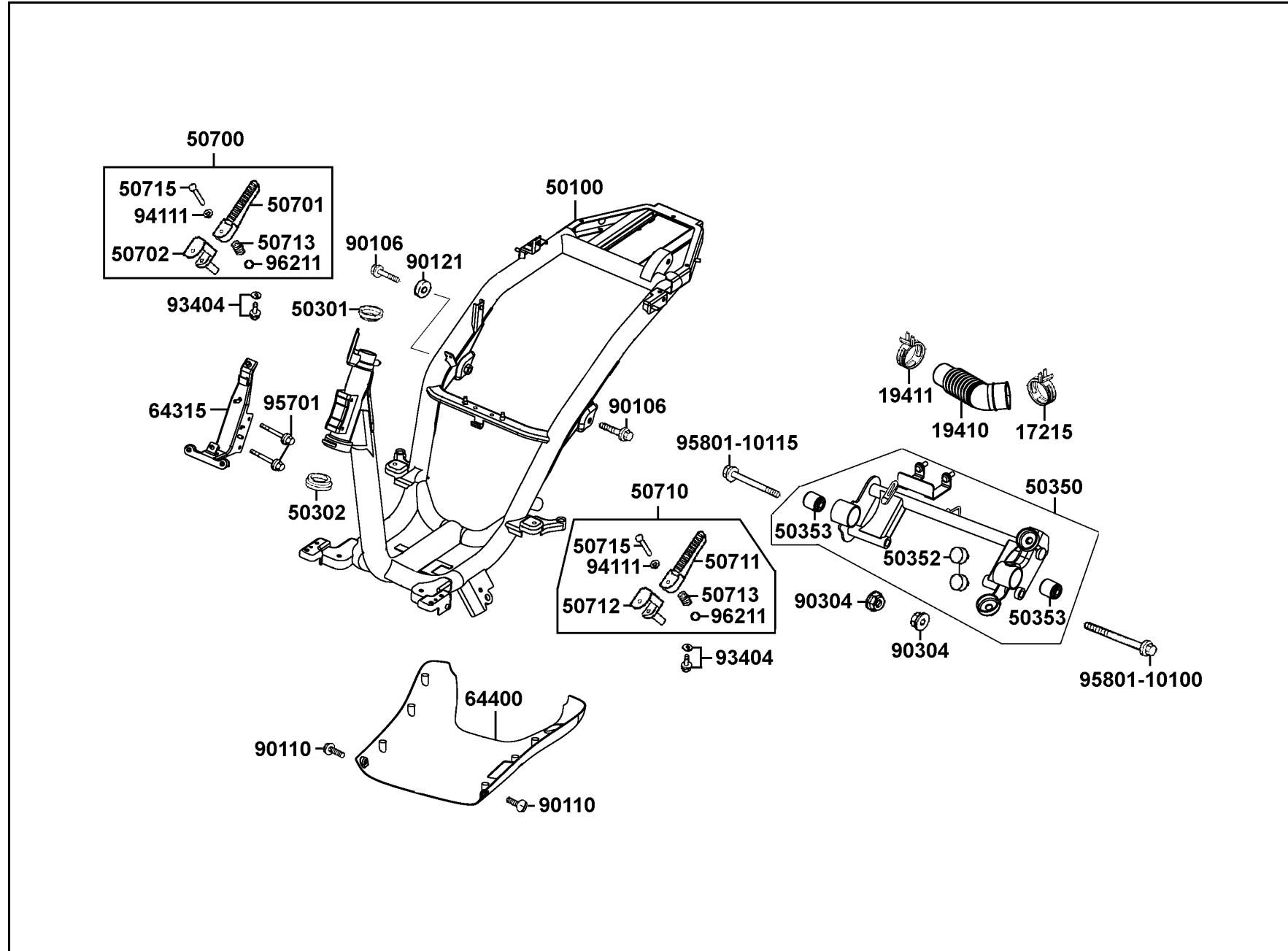

販賣記號	項目	零件號碼	版數	英文名稱	中文名稱	需要用量	參考價
Sales mark	Ref no	Part no	Ver	Description	Chinese	Regd no	Ref Price
		90110-GW0-0010	0	SCREW SPECIAL 6*14	螺絲 6*14	2	
		90121-GY6-9010	0	COLLAR DISTANCE	套筒	1	
		90304-GE8-0040	0	NUT U 10MM	螺帽 10MM	2	
		93404-06012-08	0	BOLT WASHER 6*12	螺絲 6*12	2	
		94111-06800	0	WASHER SPRING 6MM	華司 6MM	2	
		95701-06045-08	0	BOLT FLANGE 6*45	螺絲 6*45	2	
		95801-10100-07	0	BOLT FLANGE 10*100	螺絲 10*100	1	
		95801-10115-07	0	BOLT FLANGE 10*115	螺絲 10*115	1	
		96211-08000	0	BALL STEEL 8MM	鋼珠 8MM	2	

F 22 Air Cleaner Two

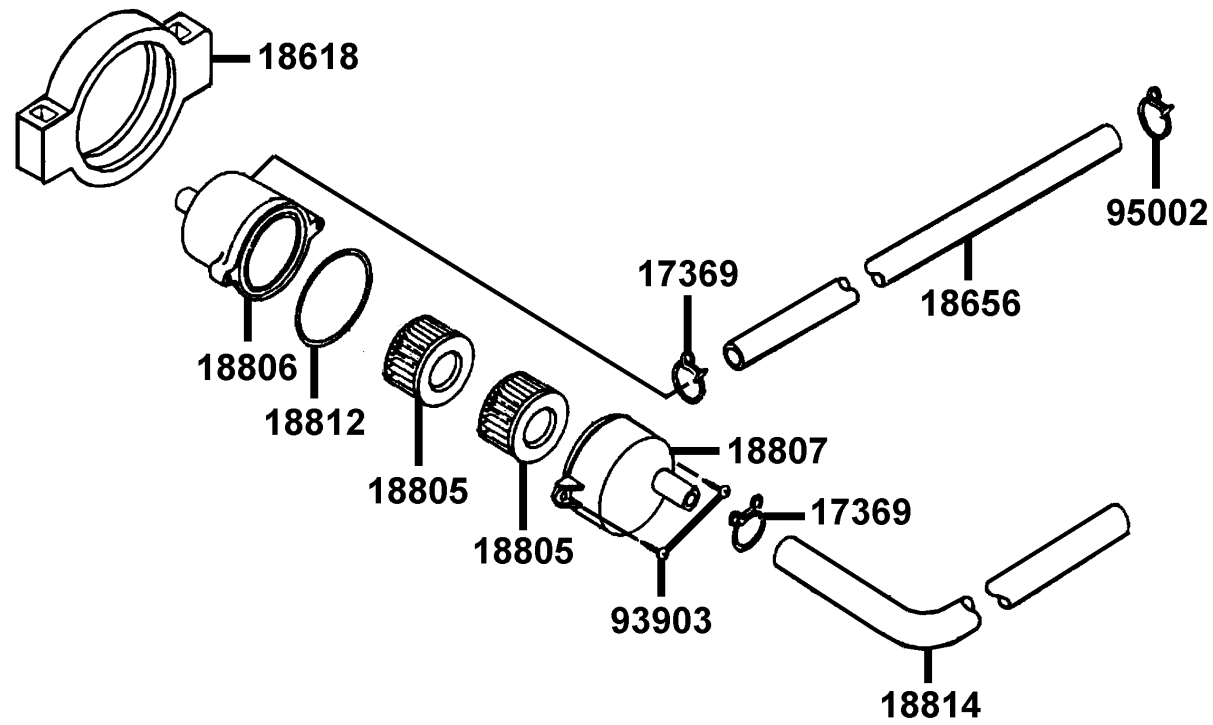

販賣記號 Sales mark	項目 Ref no	零件號碼 Part no	版數 Ver	英文名稱 Description	中文名稱 Chinese	需要用量 Regd no	參考價 Ref Price
		17369-KB4-6700	1	CLIP BREATHER TUBE	通氣管夾	2	
		18618-KE2-9000	0	RUBBER AI CLEANER MOUNT	二次空氣濾清器懸掛橡皮	1	
		18656-KFA6-EZ0	0	TUBE AI/C REED VALVE	通氣管	1	
		18805-KHB4-910	0	ELEMENT AI CLEANER	空氣海綿濾清器	2	
		18806-KE2-900	1	CASE AI CLEANER	二次空氣濾清器箱	1	
		18807-KE2-900	3	COVER AI CLEANER	二次空氣濾清器蓋	1	
		18812-KE2-9000	0	SEAL AI CLEANER COVER	二次空氣濾清器防水封	1	
		18814-KFA6-EZ0	0	DUCT AI CLEANER	導管	1	
		93903-24380	0	SCREW TAPPING 4*12	螺絲 4*12	2	
		95002-KKD6-E05	0	CLAMP D18 TUBE	管夾	1	

F 23 Separated Pats Of Fr Fork

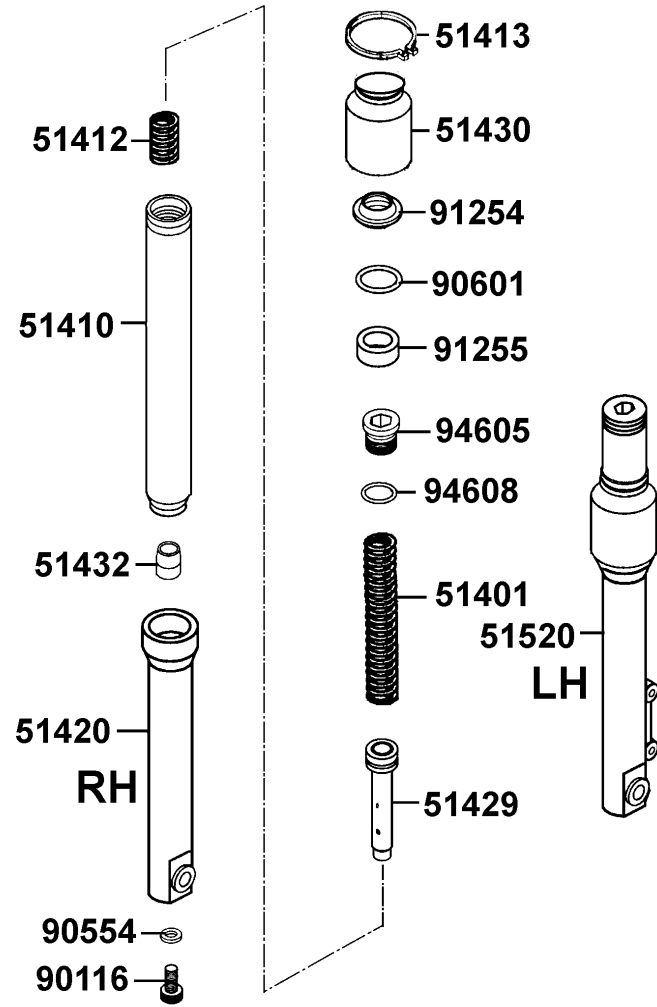

販賣記號	項目	零件號碼	版數	英文名稱	中文名稱	需要用量	參考價
Sales mark	Ref no	Part no	Ver	Description	Chinese	Regd no	Ref Price
		51401-KFA6-E000	0	SPRING	彈簧	2	
		51410-KFA6-9000	0	FORK PIPE COMP	前避震器管	2	
		51412-KFA6-E000	0	REBOUND SPRING	回位彈簧	2	
		51413-KBE-E000	0	BOOT BAND	護套夾	2	
		51420-KFA6-9000	0	BOTTOM CASE R	右前避震器底管	1	
		51429-KFA6-9000	0	PIPE SEAT COMP	避震管座	2	
		51430-KFA6-9000	0	BOOT FR FORK	護套	2	
		51432-KFA6-9100	0	OIL LOCK PIECE	止油接頭	2	
		51520-KFA6-9000	0	BOTTOM CASE L	左前避震器底管	1	
		90116-383-7220-M1	0	BOLT SOCKET 8*27	內六角螺絲 8*27	2	
		90554-283-0010	0	WASHER SPECIAL 8MM	特殊華司 8MM	2	
		90601-354-0010	0	OIL SEAL STOPPER RING	油封止位環	2	
		91254-KC5-0030	0	DUST SEAL	防塵封	2	
		91255-446-0140	0	OIL SEAL	油封	2	
		94605-KBE-9000	1	FORK BOLT	螺絲	2	
		94608-30000	0	O-RING	O環	2	

F 24 Caution Label

● Be sure to wear a safety helmet when riding.
 ● Do not exceed the speed specified by law when riding.
 ● The exhaust muffler temperature is very high after riding. Be sure to park the motorcycle in a place not easily touched by people.
 ● For riding safety and good performance, do not violate the law to modify the motorcycle.

● Make sure to perform the periodic maintenance and periodic inspection.

Provide inspection items
 Brake performance, tires, 2cycle motor oil, lights, horn, and instrument panel.

KWANG YANG MOTOR CO., LTD.
 KBN-E000

87560

CAUTIONS

Never put any article between the rear side cover and the engine to avoid interference of riding.

GM9-300

87542

CAUTION

- The weight of articles put in the inner box shall not exceed 1.5kgs
- Water may enter into the box when washing the motorcycle be careful when putting important articles in it.

81218

CAUTIONS

Tire Size	: Front 80/80-16	Rear 100/80-16
(One Rider)	: Front 1.75kg/cm ²	Rear 2.0 kg/cm ²
(Two Rider)	: Front 1.75kg/cm ²	Rear 2.25kg/cm ²
Load Capacity	: Shield 1.5kg	Rear carrier 5kg
	Inner box under saddle 10kg	

(Note: The tire pressure must not overpass 2.8kg/cm²)

When refilling gasoline, check the motor oil level. Riding with insufficient motor oil will cause breakdown easily.

KH84-E000

87505

CAUTIONS

Before starting the engine, the side stand shall be kicked up to secure safety.

87541

TRADE NAME: KYMCO PEOPLE 50
 VEHICLE CATEGORY: A

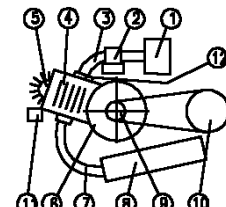

1	☑ KYMCO KFA6
2	KEJHN KT PB
3	KYMCO KEB7
4	KYMCO KEB7
5	KYMCO KEB7
6	KYMCO KFA6
7	-----
8	☑ KYMCO KFA6II
9	KY GAK φ88
10	KEB7 φ118.5
11	KYMCO KGB5
12	-----

KFA6-F1

87224

販賣記號 Sales mark	項目 Ref no	零件號碼 Part no	版數 Ver	英文名稱 Description	中文名稱 Chinese	需要用量 Regd no	參考價 Ref Price
		81218-KAC-P00	0	CAUTION INNER BOX	警告標籤	1	
		87224-KFA6-EZ1	0	CAUTION ANIT TAMPERING	防改裝貼紙	1	
		87505-KHB4-E00	0	LABEL TIRE	胎壓標籤	1	
		87541-GR1-E00	1	CAUTION SIDE STAND	警告標籤	1	
		87542-GR1-E00	1	MARK MAINT CAUTION	警告標籤	1	
		87560-KBN-E00	1	MARK DRIVE CAUTION	標籤	1	

people

86202

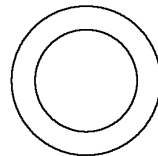

86030



87311

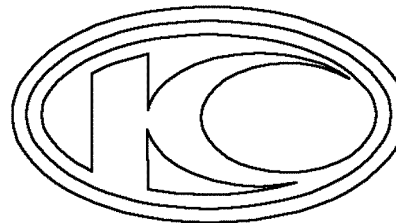

86102

販賣記號	項目	零件號碼	版數	英文名稱	中文名稱	需要用量	參考價
Sales mark	Ref no	Part no	Ver	Description	Chinese	Regd no	Ref Price
		86030-KFA6-E00	0	EMB HANDLE COVER RR	手柄後蓋標誌	4	
		86102-KFA6-E00	0	EMB K-LOGO 30MM	標誌	1	
		86202-KFA6-E00	0	EMB BODY COVER	車體邊蓋標誌	2	
		87311-KKD6-E00	0	STRIPE MARK EURO 2	EURO 2標誌	1	

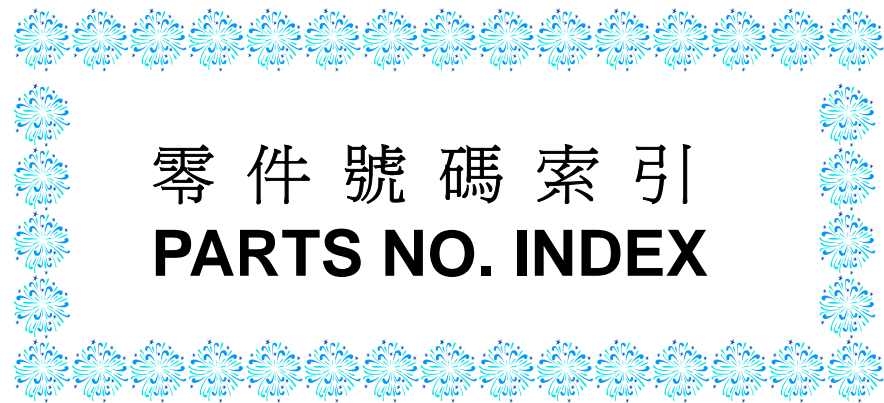

零件號碼索引
PARTS NO. INDEX

零件號碼索引

PART NO. INDEX

零件號碼 PART NO.	版數 VERSION	頁次 PAGE	零件號碼 PART NO.	版數 VERSION	頁次 PAGE	零件號碼 PART NO.	版數 VERSION	頁次 PAGE
1000			13000			17000		
1001-GC8H-0351	0	P-39	13000-GAK-921	6	P-37	1703-GJ2H-0040	0	P-39
1010-GAKH-9200	0	P-39	1300-GW0H-9000	0	P-39	17100-KEB7-E000-GM	0	P-33
1020-GAKH-9300	0	P-39	13011-GW0-9020	0	P-37	17111-KEB7-9000	0	P-33
103J-073H-9900-SB00	0	P-39	13101-GW0-9010	1	P-37	17112-KEB7-900	1	P-33
105B-KBNH-9000	0	P-39	13111-166-0010	1	P-37	17205-KFA6-9000	0	P-81
			13115-156-0010	0	P-37	17208-GR1-0110	0	P-81
						1720A-KFA6-E00	0	P-81
11000			14000			18000		
11100-KEB7-3250	5	P-33				17210-KFA6-9000	0	P-81
11102-187-0030	3	P-33	14100-KEB7-9000	0	P-33	17212-KFA6-9000	0	P-81
11108-KEB7-9000	0	P-19				17215-KBN-2000	0	P-95
11200-KFA6-305	1	P-33				17369-KB4-6700	1	P-99
11203-GC7-3010	2	P-33	15000			17502-187-0000	0	P-75
11203-KDU-9000	0	P-31				17510-KFA6-800	6	P-69
11204-KEB7-9000-H1	0	P-33	15100-KEB7-E000	0	P-33	17530-KFA6-9000	0	P-69
11205-GAH-0040-H1	0	P-23	15110-KEB7-9000	0	P-33	17550-KFA6-9000	0	P-69
11205-GAH-0040-H1	0	P-33	1552A-KEB7-9010	0	P-33	1762A-KFA6-9000	3	P-69
11205-KED5-9000-H1	0	P-33	15772-551-0000	1	P-69	17685-KCZ-9000	0	P-69
11208-GAK-9010	0	P-33	15772-551-0000	1	P-75	1785-KBNH-9000-SB00	0	P-39
11341-KFA6-900	0	P-23	16000			1787-KG8H-9010	0	P-39
11395-KFA6-9000	0	P-23				17910-KFA6-9000	0	P-49
11396-KFA6-9000	0	P-23	1610K-KFA6-E500	1	P-39	1793-144H-9900	0	P-39
			16152-KG8-9010-M1	0	P-39	1799-KBNH-9000	0	P-39
12000			1621A-GAK-9010	0	P-33			
12101-KFA6-E100	0	P-17	16620-KEB7-E000	1	P-39	18291-166-0040	0	P-83
12191-KEB7-9000	0	P-17	16630-KEB7-E000	0	P-15	18293-GY6-9000	0	P-83
12201-KFA6-E100	0	P-17	16950-KEC8-9000	3	P-69	1830A-KFA6-E05	0	P-83
12251-KEB7-9000	0	P-17	16955-KFA6-9000	0	P-69	18318-KAF-E000	0	P-83
12311-KFB5-900	2	P-83	16960-KEC8-9000	0	P-69	18601-KFB5-9000	0	P-83
						18612-KFB5-9000	0	P-83

零件號碼索引

PART NO. INDEX

零件號碼 PART NO.	版數 VERSION	頁次 PAGE	零件號碼 PART NO.	版數 VERSION	頁次 PAGE	零件號碼 PART NO.	版數 VERSION	頁次 PAGE			
18618-KE2-9000	0	P-99	22300-KCX-9000	0	P-27	30000					
18645-KGB5-EZ0	1	P-83	22350-GAK-9300	1	P-27						
18656-KFA6-EZ0	0	P-99	22401-GG2-9000	0	P-27						
18805-KHB4-910	0	P-99	22530-GAK-9300	1	P-27	30400-KFA6-E0A	3	P-93			
18806-KE2-900	1	P-99	22804-148-0010	0	P-27	3051A-KFA6-9000-M2	1	P-93			
18807-KE2-900	3	P-99	23000			30700-KBN-9010	2	P-93			
18812-KE2-9000	0	P-99									
18814-KFA6-EZ0	0	P-99									
19000						2301A-KEB7-2200	0	P-27	31000		
						23100-KEB7-9000	0	P-27			
						23200-GR1-2200	0	P-27			
19410-KFA6-9000	0	P-95				23220-GAK-2200	0	P-27	31110-KEB7-9000-M1	2	P-19
19411-KBN-9000	1	P-95				23225-GR1-7510	0	P-27	31110-KEB7-9000-M2	1	P-19
19510-GW2-9010	2	P-19				23233-GE8-0010	2	P-27	31120-KFA6-9000-M1	2	P-19
19600-KEB7-9000	0	P-15				23237-GR1-2200	0	P-27	31120-KFA6-90B	2	P-19
1962A-KEB7-E000	0	P-15	23238-GY6-9410	0	P-27	31209-GAK-9010	3	P-21			
21000			23237-GR1-2200	0	P-27	31210-GAK-9000-M3	1	P-21			
			23411-KFA6-9000	0	P-31	31500-KBN-9210-M1	3	P-73			
			23420-KFA6-9000	0	P-31	31600-KDU-9000	0	P-93			
			23431-KBN-9010-H1	1	P-31	32000					
			23432-KFA6-9000	0	P-31						
			21200-KFA6-3050	0	P-31						
21395-KFA6-9000	0	P-31	28000			32100-KFA6-900	4	P-93			
22000						28211-KEB7-9000	0	P-25	32105-KFA6-9000	0	P-21
						28223-KBN-9010	0	P-25	32120-155-0010	0	P-93
						28230-GAK-9210	0	P-25	32161-393-0040	0	P-15
						28250-KCC-9000	0	P-25	33000		
22100-GR1-7510	0	P-27									
22102-KEB7-9000	0	P-25									
22103-KEB7-9000	0	P-25	28253-GN2-6020-M1	0	P-25	33100-KFA6-9000	0	P-45			
22105-KFA5-8000	0	P-25	28255-GS6-0010	0	P-25	33105-KFA6-900	0	P-45			
22110-KFA1-2200	0	P-25	28281-GN2-6030-M1	1	P-25	33120-KFA6-9000	0	P-45			
22121-GW0-9010	2	P-25	28300-KFA6-9000	1	P-85	33130-KFA6-9000	0	P-45			
22131-GAH-7810	0	P-25				33155-KFA6-900	0	P-45			
22132-GW0-0010	2	P-25									

零件號碼索引

PART NO. INDEX

零件號碼 PART NO.	版數 VERSION	頁次 PAGE	零件號碼 PART NO.	版數 VERSION	頁次 PAGE	零件號碼 PART NO.	版數 VERSION	頁次 PAGE
33400-KFA6-E200	0	P-89	35151-KGBG-9100	1	P-49			
33402-KFA6-9100	0	P-89	35152-KGBG-9000	2	P-49	4000		
33410-KFA6-9100	0	P-89	3515A-KGBG-E000	2	P-49			
33420-KFA6-9100	0	P-89	35201-KGBG-9100	1	P-49	4000-077-0000	0	P-39
33450-KFA6-E200	0	P-89	35202-KGBG-9000	2	P-49			
33452-KFA6-9100	0	P-89	3520A-KGBG-E00	3	P-49			
33600-KFA6-E000	2	P-89	35340-KFA6-900	0	P-55	42000		
33602-KFA6-E000	0	P-89	35340-KJ9-0100	4	P-49			
33607-KFA6-E00	0	P-89	35400-KBN-9200	0	P-93	42601-KFA6-900	1	P-65
33650-KFA6-E000	2	P-89	35410-KEB7-9000	0	P-75	42710-KHB4-90A	0	P-65
33652-KFA6-E000	0	P-89				42710-KHB4-90B	0	P-65
33700-KFA6-E000	1	P-91				42753-KBN-9020-M2	0	P-63
33704-KFA6-9000	0	P-91	37000			42753-KBN-9020-M2	0	P-65
33741-GY6-C300	1	P-91						
33741-KFA6-9000	0	P-91	37200-KFA6-E000-FL-M1	2	P-47			
			37200-KFA6-E000-FL-M2	1	P-47	43000		
34000			37211-KFA6-9000-M1	0	P-47			
			37211-KFA6-9000-M2	0	P-47	4312A-KDU-900	4	P-65
			37213-KFA6-9000-M1	0	P-47	43141-KFA6-9000	0	P-65
34901-KFA6-9000	0	P-45	37213-KFA6-9000-M2	0	P-47	43151-KM7-9600	1	P-65
34903-KCP-9000	0	P-45	37280-KFA6-9000	0	P-47	43410-KFA6-9000	1	P-65
34905-KCP-9000	0	P-89	37801-GA7-7000	1	P-69	43450-KFA6-9000	1	P-49
34906-KCP-9000	0	P-91	37802-KEC8-9000	0	P-69	43452-GAK-9000	0	P-49
34908-GA7-7010-M1	1	P-47	3780A-KFA6-9000	0	P-69	43472-161-0010	0	P-49
34908-MB9-8710-M1	0	P-47						
35000			38000			44000		
			38110-GS7-E000-M1	2	P-93	44301-KAA-900	4	P-63
35010-KFA6-E000-M1	1	P-93	38300-KCE-9000	1	P-47	44311-046-0010	0	P-63
35010-KFA6-E000-M2	1	P-93	38306-292-C110	0	P-47	44600-KFA6-305	0	P-63
35101-KFA6-3050-M1	0	P-93	38500-KFA6-9000	0	P-93	44620-400-0000	1	P-63
35101-KFA6-3050-M2	0	P-93				44710-KHB4-90A	0	P-63
35102-KGBG-9100-M1	0	P-93				44710-KHB4-90B	0	P-63
35102-KGBG-9100-M2	0	P-93				44800-KFA6-9000	0	P-63

零件號碼索引

PART NO. INDEX

零件號碼 PART NO.	版數 VERSION	頁次 PAGE	零件號碼 PART NO.	版數 VERSION	頁次 PAGE	零件號碼 PART NO.	版數 VERSION	頁次 PAGE
64000			80106-KFA6-9000	0	P-91	86000		
64301-KFA6-900	2	P-57	80151-KFA6-900	0	P-77	86030-KFA6-E00	0	P-105
64302-KFA6-900	1	P-57	80153-KFA6-900	0	P-77	86102-KFA6-E00	0	P-105
64303-KFA6-9000	0	P-57	80161-KFA6-900	0	P-77	86202-KFA6-E00	0	P-105
64310-KFA6-900	2	P-57	81000			87000		
64315-KFA6-9000	0	P-95	81131-KFA6-900	1	P-57	87224-KFA6-EZ1	0	P-103
64320-KFA6-900	0	P-57	81132-KFA6-900	0	P-57	87311-KKD6-E00	0	P-105
64400-KFA6-900	0	P-95	81133-KBG-9000	0	P-57	87505-KHB4-E00	0	P-103
75000			81134-KFA6-9000	0	P-57	87541-GR1-E00	1	P-103
75581-673-0010	0	P-57	81135-KGBG-900	2	P-57	87542-GR1-E00	1	P-103
77000			81141-KFA6-900	0	P-57	87560-KBN-E00	1	P-103
77106-KEB7-9000	0	P-77	81142-KFA6-9000	0	P-57	88000		
77200-KFA6-900	0	P-67	81146-GN2-0010	0	P-57	88110-KFA6-9000	1	P-51
77210-KFA6-900	0	P-67	81200-KFA6-900	0	P-77	88120-KFA6-9000	1	P-51
77232-GW0-3150-M2	0	P-57	81201-KFA6-9000	1	P-77	89000		
77239-KFA6-3050-M1	0	P-67	81204-KFA6-9000	0	P-77	89010-KBN-9000	0	P-67
77239-KFA6-3050-M2	0	P-67	81218-KAC-P00	0	P-103	90000		
77300-KFA6-900	0	P-67	81260-KFA6-E00	0	P-77	90001-GAK-9010	0	P-17
77303-KFA6-9000	1	P-67	83000			9000A-KDT-9000	0	P-23
77305-KFA6-9000	0	P-67	83500-KFA6-900	2	P-77	90101-GR1-0010	0	P-45
77306-KFA6-900	0	P-67	83501-KFA6-9000	0	P-77	90105-KR3-0010	1	P-63
80000			83502-KFA6-9000	0	P-77			
80101-KFA6-9000	0	P-91	83600-KFA6-900	2	P-77			
80105-KFA6-900	1	P-91	83601-KFA6-9000	0	P-77			
			83602-KFA6-9000	0	P-77			

零 件 號 碼 索 引

PART NO. INDEX

零 件 號 碼 PART NO.	版 數 VERSION	頁 次 PAGE	零 件 號 碼 PART NO.	版 數 VERSION	頁 次 PAGE	零 件 號 碼 PART NO.	版 數 VERSION	頁 次 PAGE
90106-GN5-9010	0	P-51	90304-GE8-0040	0	P-97	91202-KBN-9220-M1	0	P-35
90106-GY6-9010	0	P-95	90305-KBN-9030	0	P-65	91204-KBN-9020-M1	1	P-35
90106-KDU-9000	1	P-77	90306-KF0-901	0	P-63	91211-GK8-0130	0	P-27
90106-KFC2-9000	0	P-51	90307-GJ6-0040	0	P-45	91252-030-0000	0	P-63
90108-KFA6-E000	0	P-85	90309-KF0-0030	1	P-31	91254-KC5-0030	0	P-101
90110-GW0-0010	0	P-57	90412-329-0010	0	P-25	91255-446-0140	0	P-101
90110-GW0-0010	0	P-97	90426-KBN-9010	0	P-25	91255-GE0-0060	0	P-31
90111-187-0000	1	P-67	90429-KBN-9010	0	P-31	91258-410-0000-M2	0	P-63
90111-187-0000	1	P-69	90442-044-0000	0	P-27	91301-053-0010	0	P-31
90111-KW6-0010	0	P-77	90451-GN2-6010	0	P-25	91301-KA5-7420-Y1	0	P-29
90112-KDR-9000	0	P-93	90454-GB2-0000	0	P-27	91302-PA9-0040	0	P-29
90114-166-0070	1	P-55	90474-333-0010	0	P-33	91304-GB0-9110	1	P-35
90114-GM4-0110	1	P-81	90501-KBN-9010	0	P-65	91309-GAK-9010	0	P-21
90115-GE0-0010	0	P-51	90545-300-0010	2	P-55	91352-KG8-8330-M2	0	P-65
90116-383-7220-M1	0	P-101	90554-283-0010	0	P-101			
90120-GR1-J000	0	P-33	90601-354-0010	0	P-101			
90121-GY6-9010	0	P-97	90652-KCT-9000	0	P-81	92000		
90122-KBE-9000	0	P-63	90656-GY6-9110	0	P-51			
90145-MS9-6120-M1	0	P-55	90677-GR1-0030	1	P-59	92700-06028-1B	0	P-17
90150-463-7710-M1	0	P-45	90741-035-0010	0	P-37			
90164-MR4-9010	0	P-57						
90202-187-0010	0	P-27				93000		
90215-GM0-9100	0	P-77	91000					
90301-634-6700	0	P-57				93404-06012-08	0	P-97
90301-634-6700	0	P-91	91001-GA7-70A	0	P-27	93404-06020-07	0	P-59
90301-KGBG-9000	0	P-83	91001-GW0-90A	1	P-33	93500-05012-0H	0	P-35
90302-GY6-9010	0	P-57	91004-KBN-92A	0	P-33	93500-KGBG-9000	0	P-51
90302-GY6-9010	0	P-69	91004-KN2-90A	0	P-31	93600-04012-1G	0	P-55
90302-GY6-9010	0	P-75	91004-KN2-90A	0	P-35	93891-05030-07	0	P-51
90302-GY6-9010	0	P-91	91006-KBN-901	4	P-35	93892-04008-18	0	P-39
90302-GY6-9400	0	P-61	91009-GE0-0040	0	P-31	93892-04014-18	0	P-39
90302-KBN-9000	0	P-51	91102-GW0-009	0	P-37	93901-32010	0	P-89
90302-KED5-9000	1	P-77	91103-GR1-004	0	P-27	93901-32220	0	P-89
90302-SA4-0040	1	P-59	91201-KBN-9220-M1	0	P-35	93901-32320	0	P-89
90304-GE8-0040	0	P-51	91202-KBN-9210-M1	0	P-35	93903-24380	0	P-99

零 件 號 碼 索 引

PART NO. INDEX

零 件 號 碼 PART NO.	版 數 VERSION	頁 次 PAGE	零 件 號 碼 PART NO.	版 數 VERSION	頁 次 PAGE	零 件 號 碼 PART NO.	版 數 VERSION	頁 次 PAGE
93903-25480	0	P-81	94591-27000	0	P-59	95701-KEB7-E000	1	P-93
93903-34380	0	P-51	94591-27000	0	P-79	95801-08035-08	0	P-87
93903-34380	0	P-59	94591-KBF-900	2	P-15	95801-08040-08	0	P-61
93903-34380	0	P-67	94605-KBE-9000	1	P-101	95801-08065-07	0	P-79
93903-34380	0	P-77	94608-30000	0	P-101	95801-10035-08	0	P-87
93903-34380	0	P-89				95801-10100-07	0	P-97
93903-34380	0	P-91				95801-10115-07	0	P-97
93903-35220	0	P-45	95000			95801-KFA6-E000	0	P-83
93903-35320	0	P-47						
93903-35380	0	P-51	95002-02070	0	P-39			
93903-35380	0	P-73	95002-02070	0	P-69	96000		
			95002-02080	0	P-39			
94000			95002-02080	0	P-69	96001-06012-08	0	P-19
			95002-02100	0	P-69	96001-06012-08	0	P-51
			95002-02100	0	P-75	96001-06012-08	0	P-83
94001-05080-0S	0	P-51	95002-02650	0	P-35	96001-06016-08	0	P-19
94001-12280-0S	0	P-25	95002-50000	0	P-69	96001-06022-08	0	P-19
94050-05080	0	P-91	95002-50000	0	P-75	96001-06025-07	0	P-53
94050-06070	0	P-55	95002-KKD6-E05	0	P-99	96001-06025-08	0	P-21
94050-06080	0	P-39	9500B-KFA6-9000	0	P-71	96001-06025-08	0	P-35
94050-06080	0	P-67	9500C-KFA6-9000	0	P-71	96001-06032-08	0	P-35
94050-06080	0	P-69	95015-32001	0	P-51	96001-06045-08	0	P-35
94050-06080	0	P-77	95015-42000	0	P-51	96001-06055-08	0	P-35
94050-06080	0	P-91	95701-06008-07	0	P-83	96100-62033-00	0	P-35
94050-06080	0	P-93	95701-06016-08	0	P-79	96120-63010-10	0	P-63
94050-10080	0	P-19	95701-06022-07	0	P-55	96211-05000	0	P-61
94050-10080	0	P-29	95701-06025-08	0	P-15	96211-08000	0	P-61
94101-06700	0	P-83	95701-06025-08	0	P-83	96211-08000	0	P-97
94101-08700	0	P-85	95701-06032-08	0	P-65	96700-KFA6-9000	0	P-85
94111-06800	0	P-97	95701-06035-08	0	P-35			
94251-08400	0	P-85	95701-06040-08	0	P-35			
94301-10200	0	P-35	95701-06040-08	0	P-83	98000		
94510-20000	0	P-31	95701-06045-08	0	P-97			
94511-14000	0	P-25	95701-08012-08	0	P-35	98076-5871G-00	0	P-17
94520-24000	0	P-29	95701-08050-07	0	P-83	98200-10700	0	P-73

零 件 號 碼 索 引

PART NO. INDEX

零 件 號 碼 PART NO.	版 數 VERSION	頁 次 PAGE	零 件 號 碼 PART NO.	版 數 VERSION	頁 次 PAGE	零 件 號 碼 PART NO.	版 數 VERSION	頁 次 PAGE
98200-10700	0	P-93						
98200-11500	0	P-93						
99000								
99101-116-0700	0	P-41						
K								
K350-KEB-0500	0	P-41						
K378-001	0	P-41						
K506-GW0-0100	0	P-41						
K785-KEB-0300	0	P-41						
N								
N413-32A00	0	P-41						
N425-2RFMJ	0	P-41						
S								
S3620-031-B000	0	P-41						
S4460-213-B001	0	P-41						
S536-1241	0	P-41						