

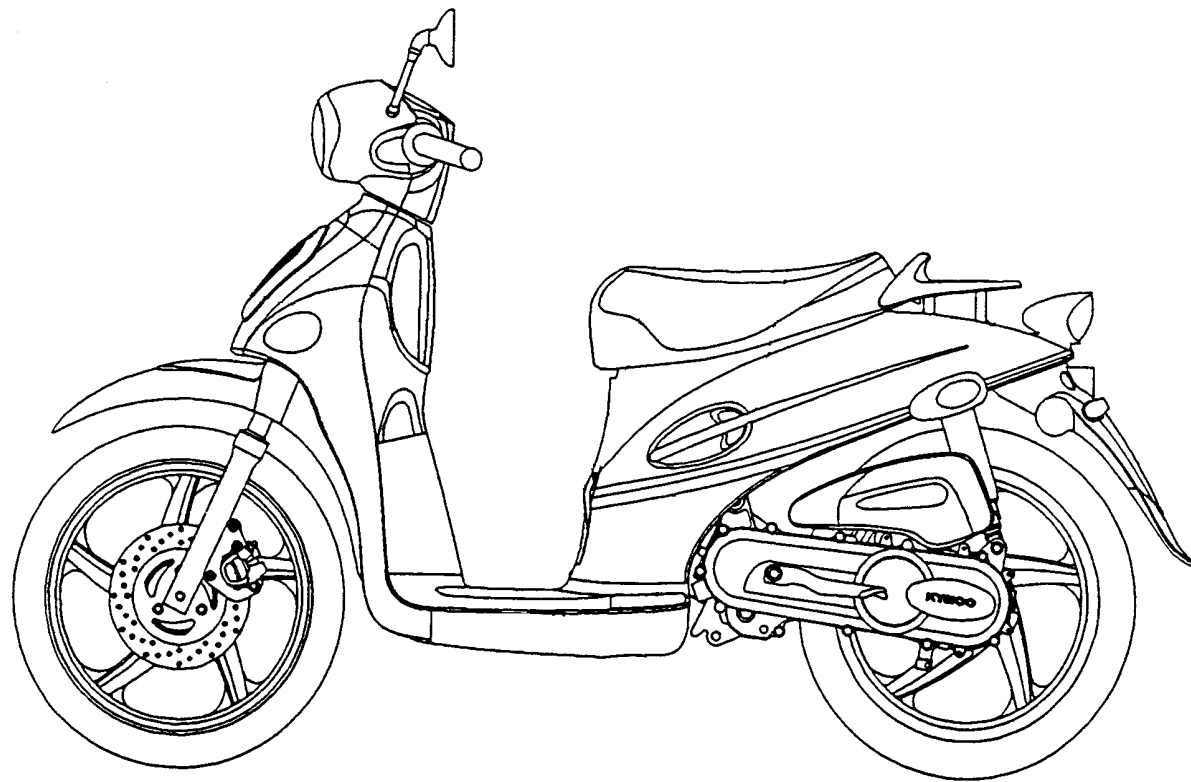

People

零件型錄
PARTS CATALOGUE

BA10AB(FL) : FEB /21 /'00 制訂



光陽機車

KYMCO

光陽機車

KYMCO

光陽機車

KYMCO

前 言

- 本零件目錄適用於 BA10AB(FL) 機種，訂購零件時，請參照本冊。
- 本冊之配色表僅供參考，若與實車不符之處，以實車為準。
- 販賣記號(Sales mark)：
 - 1、註明 ★★ 記號，表示訂購該零件時，請參照機車相片及配色表，並請在基本零件號碼最後加上色碼。
 - 2、註明 ★ 記號，表示該零件為補修零件。
- 本冊付梓印刷倉促，倘有錯誤或遺漏之處，敬請不吝賜教指正。

ABOUT THIS PARTS LIST

- This parts list is compiled all service parts for model BA10AB(FL)。
- Any difference between color chart and motorcycle will be revised according to motorcycle。
- The sales mark：
 - 1、marking "★★" must add color code in the end before ordering parts。
 - 2、marking "★" is a saleable item。
- When modification or additions to this parts list are made a revised edition at an appropriate time。

目 次

●前 言	1
●BA10AB(FL) 配色表	5
●引擎分組圖	7
●車架分組圖	9
●引擎零件號碼表	13
●車架零件號碼表	43
●零件號碼索引	103

CONTENTS

●ABOUT THIS PARTS LIST	1
●COLOR CHART OF BA10AB(FL)	5
●CONTENTS-ENGINE GROUP	7
●CONTENTS-FRAME GROUP	9
●ENGINE PARTS LIST	13
●FRAME PARTS LIST	43
●PART NO. INDEX	103

機種名稱 (MODEL)				BA10AB(FL) COLOR CHART									
項	相片號碼 (PHOTO NO)			NO.1	NO.2	NO.3	NO.4	NO.5	NO.6	NO.7	NO.8	NO.9	NO.10
次	主體色 (BASIC COLOR)			黑	白	亮銀	銀鐵灰	暗紅	深藍	墨綠	淺綠	米黃	淺藍
NO	色碼 (CODE)			Black	White	Bright Silver	Deep Blue Metallic	Dark Red	Deep Blue Metallic	Green Metallic	Light Green	Paddy Yellow	Light Blue
	色別零件名稱(PARTS NAME)	基本零件號碼(PARTS NO)	版數(VERSION)	NH001SA	NH138SA	NH045MA	NH129MA	RR132CA	PB183MA	BG055CA	GG231SA	YR034SA	PB282PA
1	COVER SET FRONT	64301-KFA6-9000	1	NH001P	NH138P	NH045P	NH129P	RR132P	PB183P	BG055P	GG231P	YR034P	PB282P
2	COVER SET R BODY	83500-KFA6-3150-IT	0										
3	COVER SET L BODY	83600-KFA6-3150-IT	0										
4	COVER FR HANDLE	53205-KFA6-E000	0										
5	FENDER FR	61100-KFA6-9000	0										
6	MOLD FRONT	64302-KFA6-9000	1										
7	COWL UNDER	64400-KFA6-9000	0										
8	COVER PLUG MAINT	80153-KFA6-9000	0										
9	COVER RR HANDLE	53206-KFA6-9000	1										
10	LEG SHIELD	81131-KFA6-9000	0	NH001R					PB181R	BG052R	GG231R	YR034R	PB283R
11	LID INNER BOX	81141-KFA6-9000	0										
12	LID LEG SHIELD	81132-KFA6-9000	0										
13	FLOOR PANEL	64310-KFA6-9000	2										
14	COVER R CENTER	80151-KFA6-9000	0										
15	COVER L CENTER	80161-KFA6-9000	0										
16	MAT FLOOR	64320-KFA6-9000	0										
17	GRIP COMP THROT	53140-KBN-9600	0										
18	GRIP L HANDLE	53166-KBN-9100	0										
19	FORK SET R FR	5140A-KFA6-E000	0	NH131A									
20	FORK SET L FR	5150A-KFA6-E000	0	NH031A									
21	BODY FR CALIPER	45200-KFA6-9000	0	NH045P									
22	WHEEL SET FR	44600-KFA6-3050	0	TYPE B					TYPE A				
23	WHEEL RR CAST	42601-KFA6-9000	0	NH045A									
24	CARRIER RR	81200-KFA6-9000	0	TYPE A									
25	SEAT COMP	77200-KFA6-9000	0										
26	COVER L SIDE	11341-KFA6-9000	0										
27	EMB K-LOGO 30MM	86102-KFA6-E000-IT	0										
28	EMB BODY COVER	86202-KFA6-E000-IT	0										
29	EMB B BODY COVER	86212-KFA6-E000-IT	0										
30	EMB HNDL COVER RR	86030-KFA6-E000	0										
31	MARK MODEL	87503-KFA6-E000-FL	0	TYPE A	TYPE B		TYPE A				TYPE B		
32													
33													
34													
35													
36													
37													
38													
39													
40													
生產日期 (DATE OF STARTING-SALES)							2000.01.24						
停產日期 (DATE OF ENDING-SALES)													

CONTENTS-ENGINE GROUP

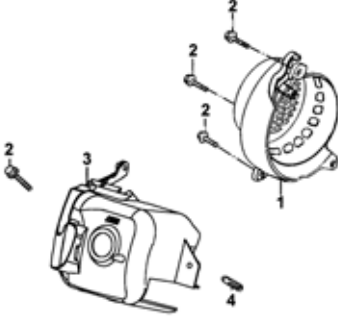
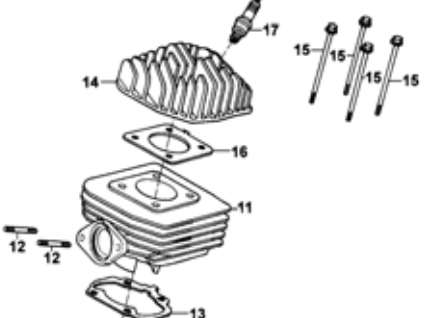
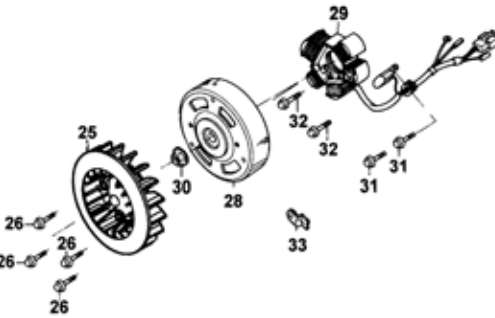
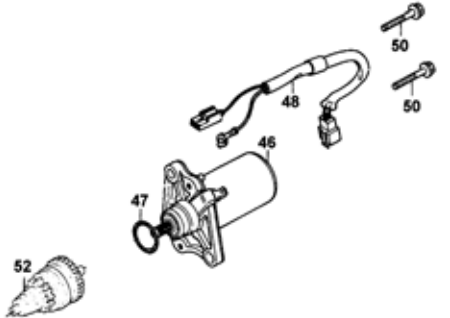
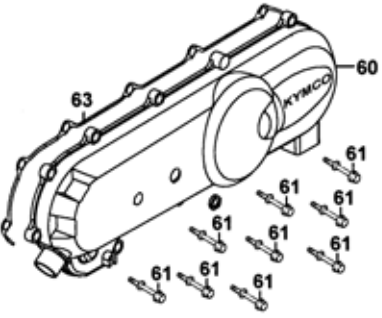
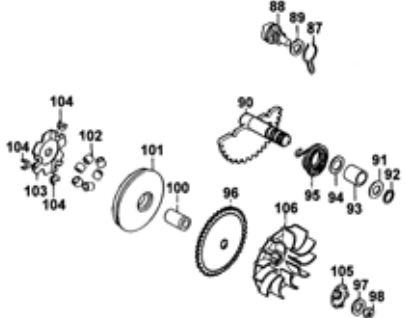
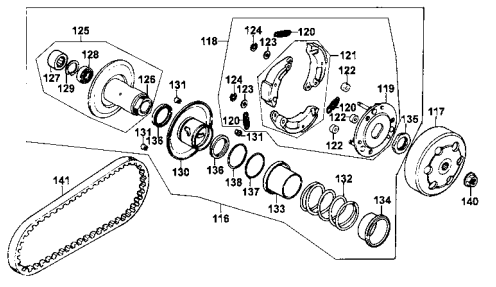
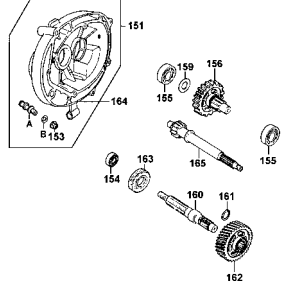
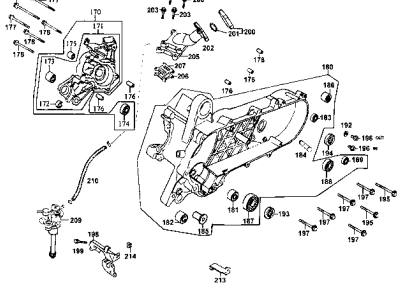
E1 Fan Cover -15-	E2 Cylinder Head Cover ● -17- Cylinder Head	E3 Generator -19-
		
E4 Starting Motor -21-	E5 Left Side Cover -23-	E6 Drive Pulley -25-
		
E7 Driven Pulley -27-	E8 Transmission -31-	E9 Crankcase ● -33- Oil Pump
		

CONTENTS-ENGINE GROUP

E10 Crankshaft●Piston -37-

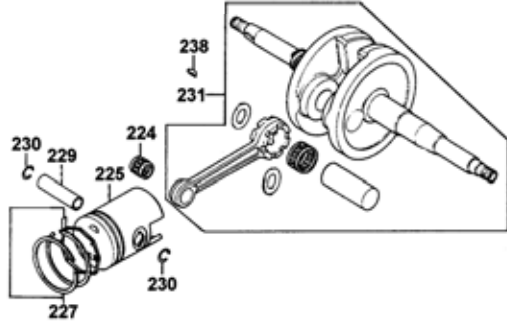

E11 Carburetor -39-

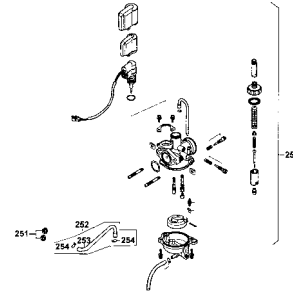

CONTENTS-FRAME GROUP

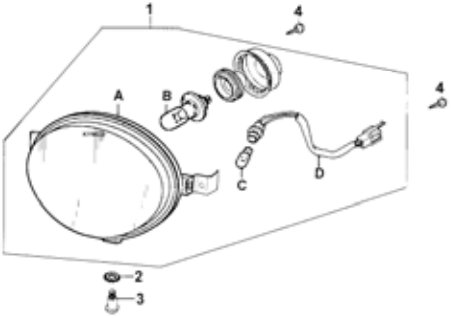
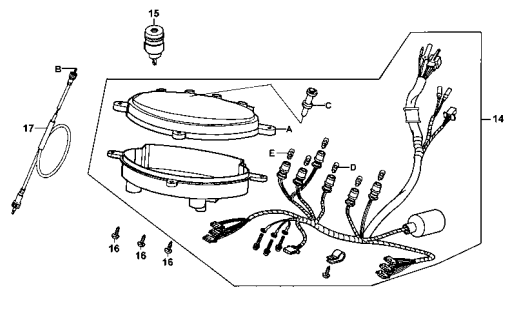
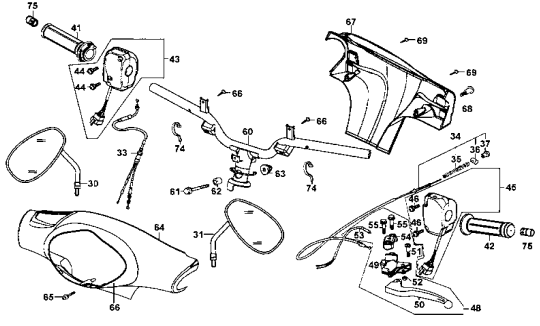
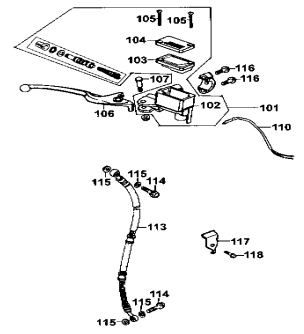
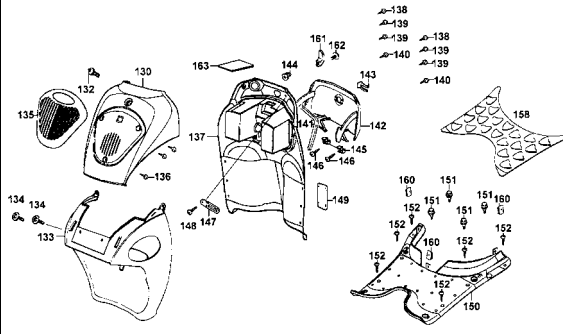
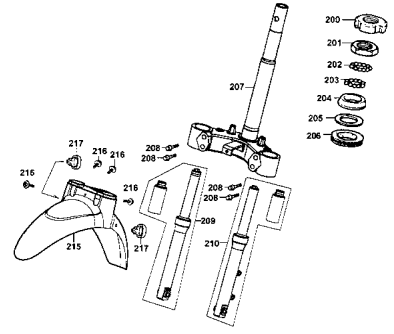
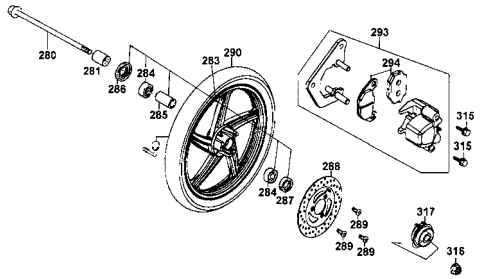
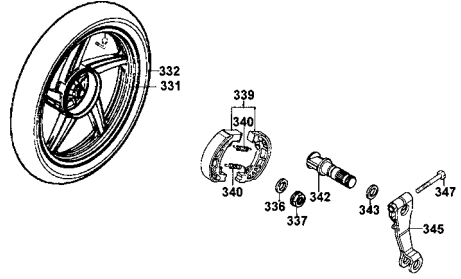
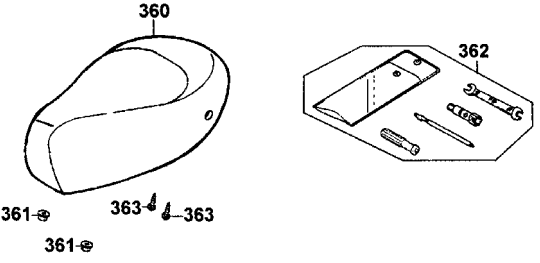
F1 Head Light -45-	F2 Speedometer -47-	F3 Handle Steering●Handle Cover -49-
		
F4 Brake Master Cylinder -53-	F5 Front Cover●Floor Panel -55-	F6 Stem Steering●Front Fork -59-
		
F7 Front Wheel -61-	F8 Rear Wheel -63-	F9 Seat -65-
		

CONTENTS-FRAME GROUP

F10 Fuel Tank

-67-

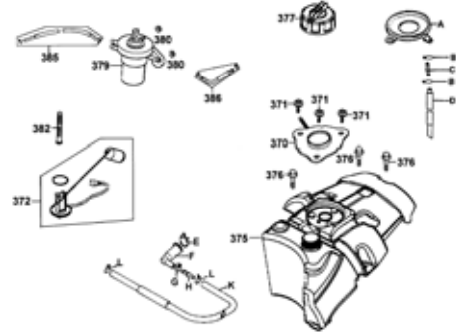

F11 Battery

-71-

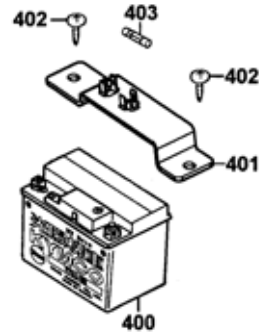

F12 Oil Tank

-73-

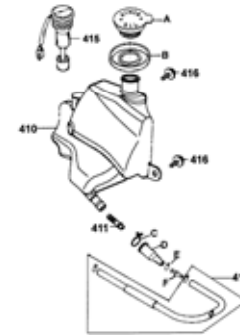

F13 Body Cover●Luggage Box

-75-

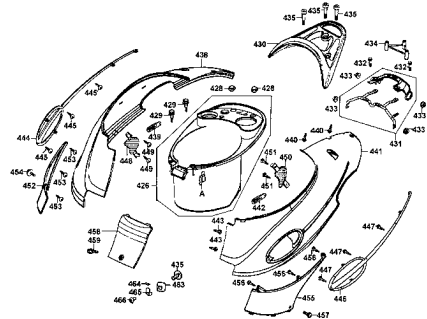

F14 Air Cleaner

-79-

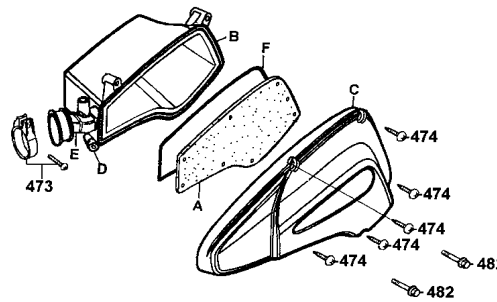

F15 Exhaust Muffler

-81-

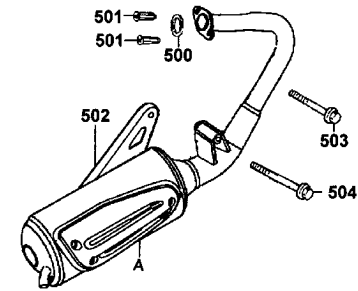

F16 Main Stand●Kick Starter Arm

-83-

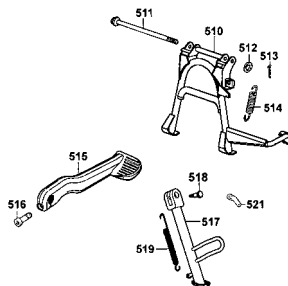

F17 Rear Cushion

-85-

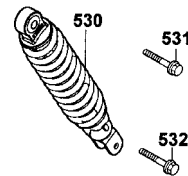

F18 Front Winker●Rear Winker

-87-

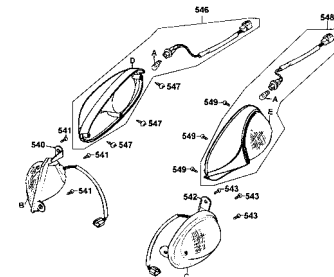

CONTENTS-FRAME GROUP

F19 Tail Light

-89-

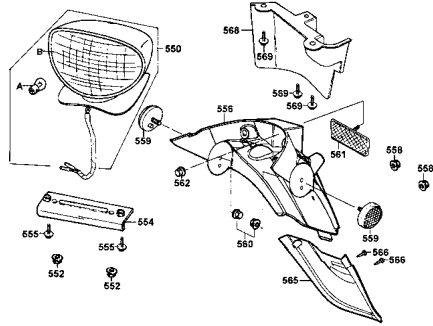

F20 Wire Harness

-91-

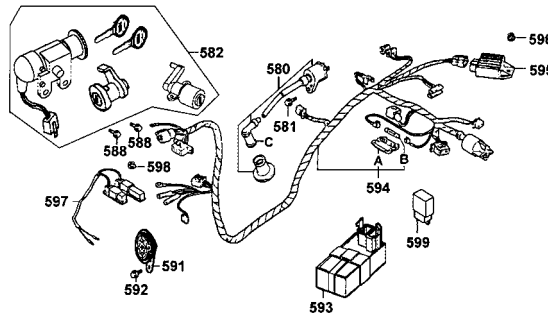

F21 Frame Body

-93-

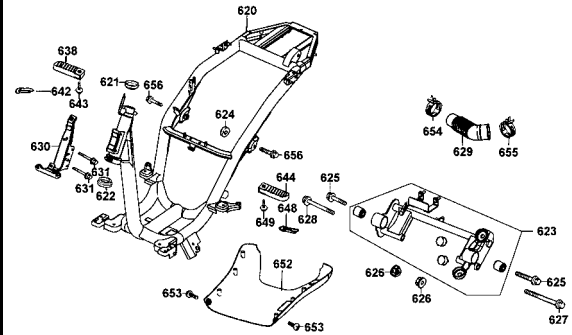

F22 Separated Parts Of Fr Fork

-97-

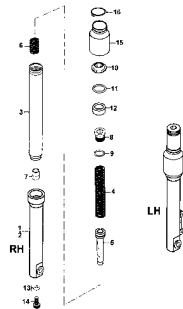

F23 Caution Label

-99-

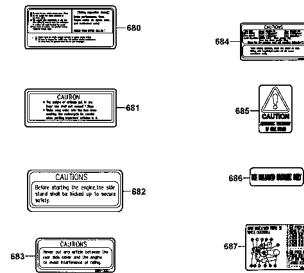

F24 Emblem Stripe

-101

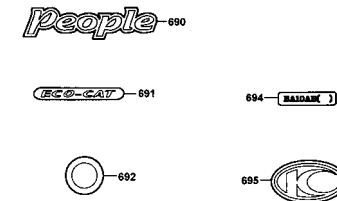

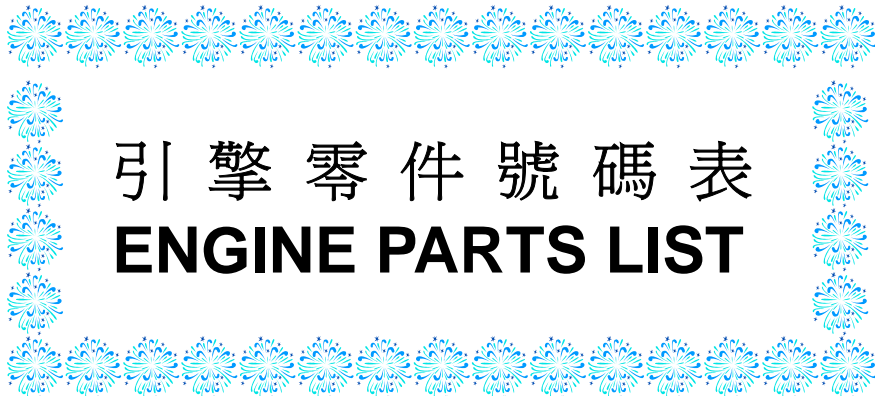

引擎零件號碼表
ENGINE PARTS LIST

E 1 Fan Cover

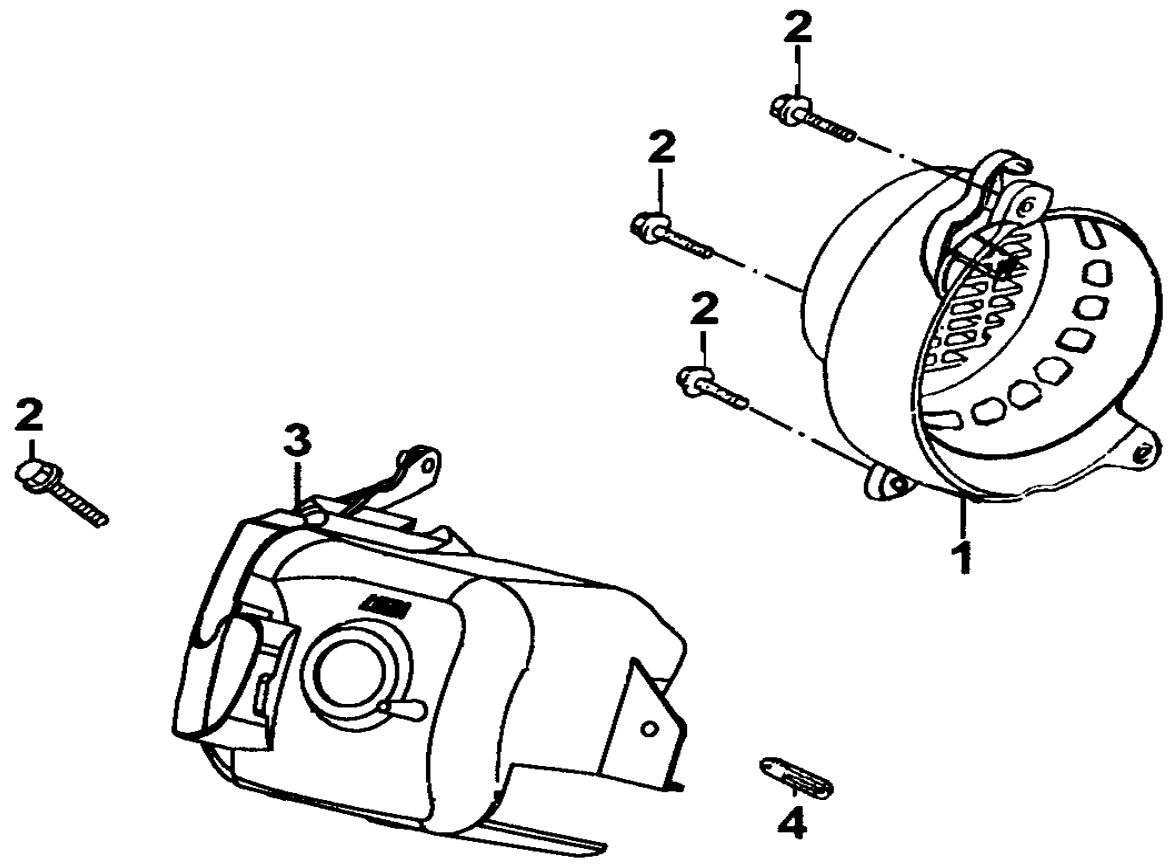

E 1

販賣記號	項目	零件號碼	版數	英文名稱	中文名稱	需要用量	參考價
Sales mark	Ref no	Part no	Ver	Description	Chinese	Regd no	Ref Price
*	1	19600-KEB7-9000	0	COVER COMP FAN	引擎罩蓋組	1	
*	2	95701-06025-08	0	BOLT FLANGE 6*25	螺絲	4	
*	3	1962A-KEB7-E000	0	CLIP SET SHROUD	引擎罩蓋	1	
*	4	94591-KBF-9000	1	CLIP 2*70	環夾	1	

E 2 Cylinder Head Cover ● Cylinder Head

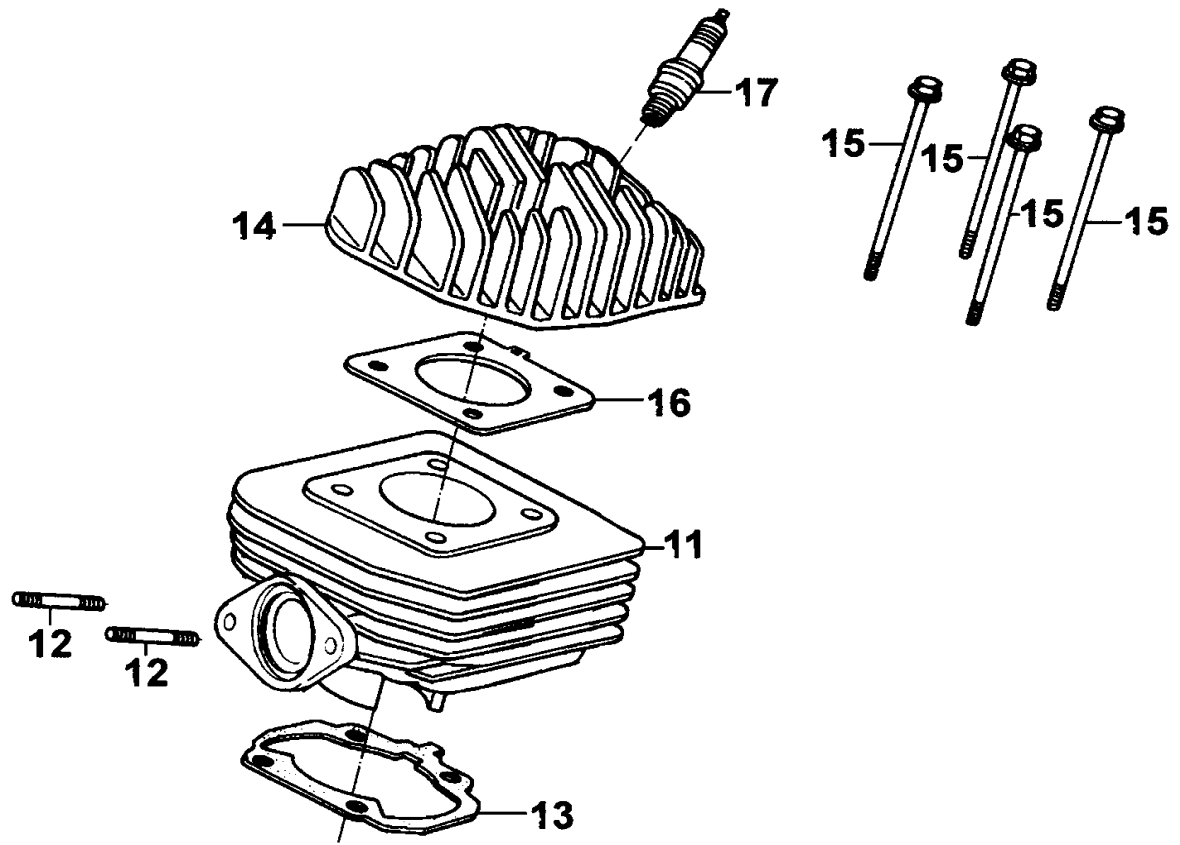

販賣記號 Sales mark	項目 Ref no	零件號碼 Part no	版數 Ver	英 文 名 稱 Description	中 文 名 稱 Chinese	需要用量 Regd no	參考價 Ref Price
*	11	12101-KFA6-E100	0	CYLINDER	汽缸	1	
*	12	92700-06028-1B	0	BOLT STUD II 6*28	雙頭螺絲	2	
*	13	12191-KEB7-9000	0	GASKET CYLINDER A	汽缸墊片	1	
*	14	12201-KFA6-E100	0	HEAD CYLINDER	汽缸頭	1	
*	15	90001-GAK-9010	0	BOLT FLANGE 7*100	特殊螺絲	4	
*	16	12251-KEB7-9000	0	GASKET CYLINDER HEAD	汽缸頭墊片	1	
*	17	98076-5871G-00	0	SPARK PLUG (BR8HSA)	火星塞	1	

E 3 Generator

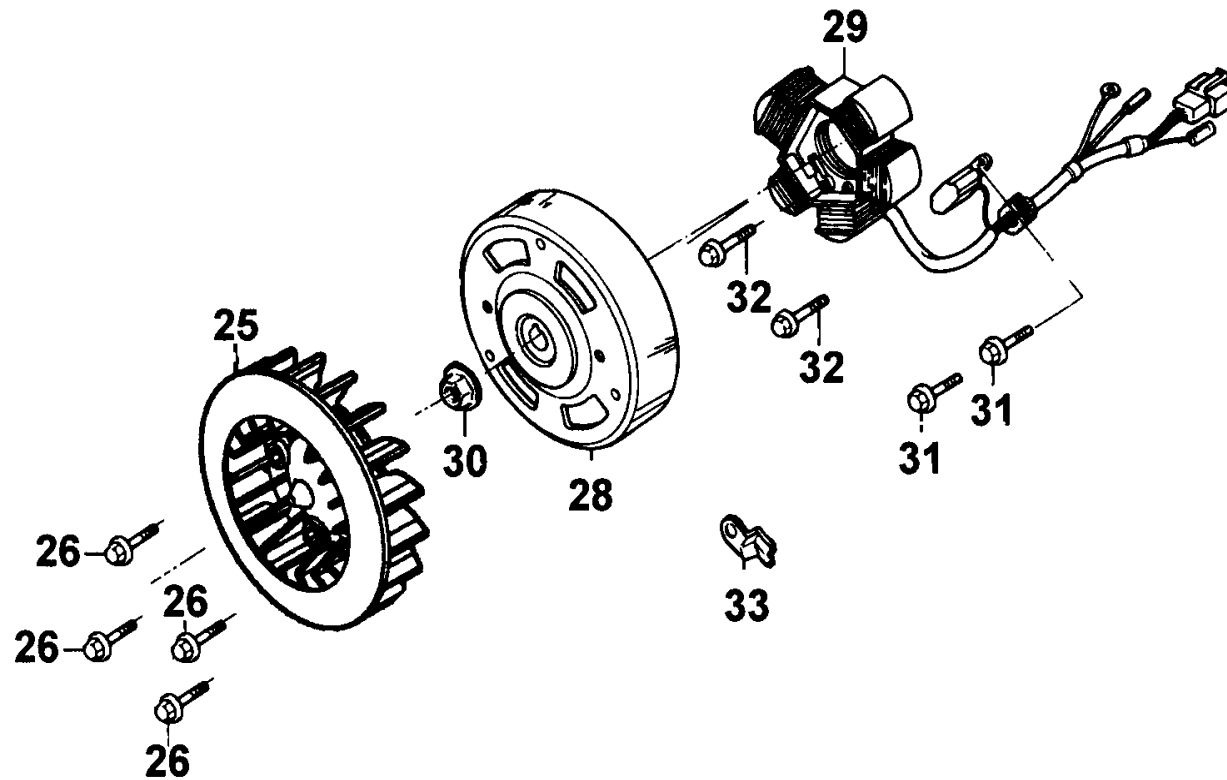

販賣記號 Sales mark	項目 Ref no	零件號碼 Part no	版數 Ver	英文名稱 Description	中文名稱 Chinese	需要用量 Regd no	參考價 Ref Price
*	25	19510-GW2-9010	2	FAN COMP COOLING	冷卻風扇	1	
*	26	96001-06016-08	0	BOLT FLANGE SH 6*16	凸緣螺栓	4	
*	28	31110-KEB7-9000-M1	2	FLYWHEEL COMP	飛輪	1	
*	28	31110-KEB7-9000-M2	1	FLYWHEEL COMP	飛輪	1	
*	29	31120-KEB7-9000-M1	2	STATOR COMP	轉子線圈	1	
*	29	31120-KEB7-9000-M2	1	STATOR COMP	轉子線圈	1	
*	30	94050-10080	0	NUT FLANGE 10MM	螺帽	1	
*	31	96001-06012-07	0	BOLT FLANGE SH 6*12	螺栓	2	
*	32	96001-06022-08	0	BOLT FLANGE SH 6*22	螺栓	2	
*	33	11108-KEB7-9000	0	HOLDER STATOR WIRE	起動馬達接地線	1	

E 4 Starting Motor

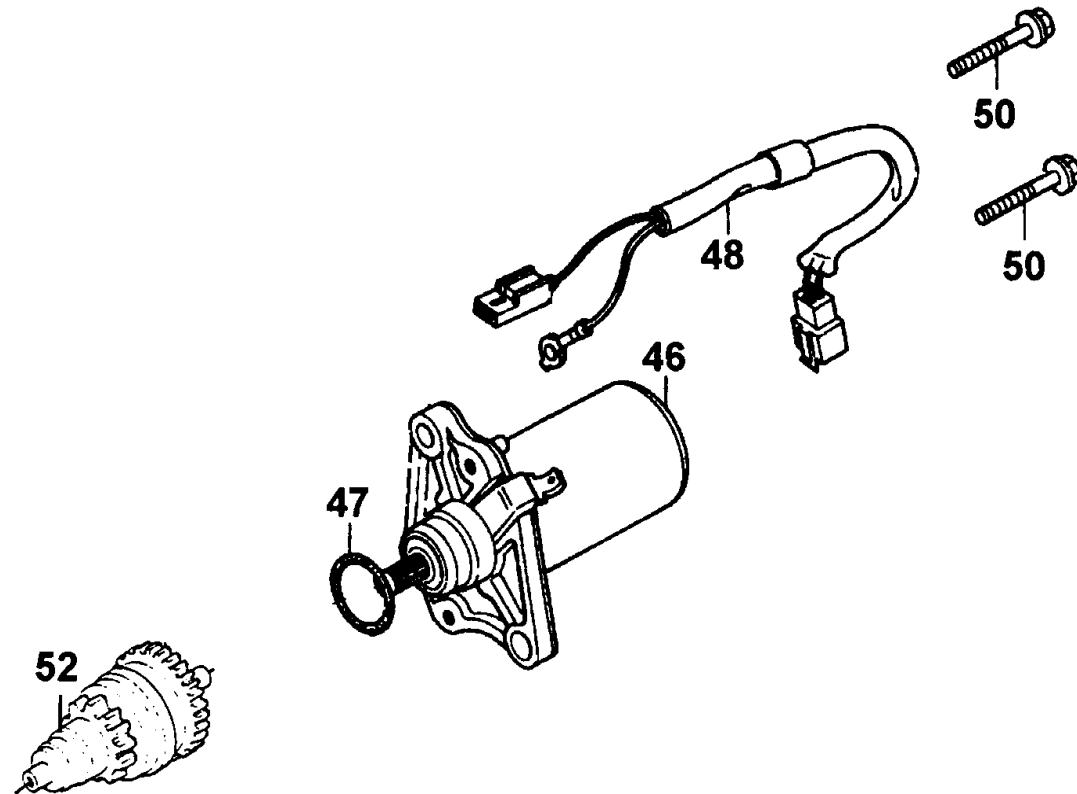

E 4

販賣記號 Sales mark	項目 Ref no	零件號碼 Part no	版數 Ver	英 文 名 稱 Description	中 文 名 稱 Chinese	需要用量 Regd no	參考價 Ref Price
*	46	31210-GAK-9000	0	MOTOR UNIT START	起動馬達組	1	
*	46	31210-GAK-9010-M1	0	MOTOR UNIT START	起動馬達組	1	
*	47	91309-GAK-9010	0	O RING	O環	1	
*	48	32105-KFA6-9000	0	SUB HARNESS	副配線	1	
*	50	96001-06025-08	0	BOLT FLANGE SH 6*25	螺栓	2	
*	52	31209-GAK-9010	1	PINION ASSY STARTER	起動齒輪組	1	

E 5 Left Side Cover

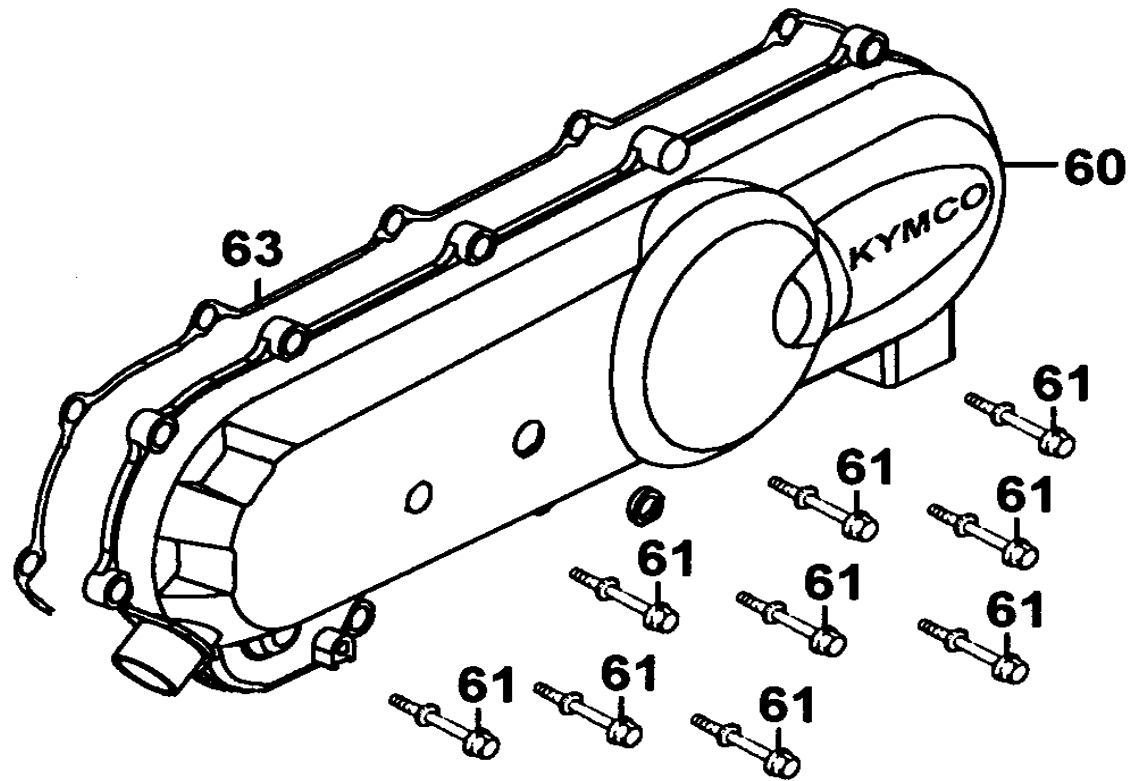

E 5

販賣記號 Sales mark	項目 Ref no	零件號碼 Part no	版數 Ver	英 文 名 稱 Description	中 文 名 稱 Chinese	需要用量 Regd no	參考價 Ref Price
**	60	11341-KFA6-9000	0	COVER L SIDE	左曲軸箱蓋	1	
*	61	9000A-KDT-9000	0	BOLT ASSY SPECIAL 6*28	特殊螺絲	9	
*	63	11395-KFA6-9000	0	GASKET L COVER	左曲軸箱蓋墊片	1	

E 6 Drive Pulley

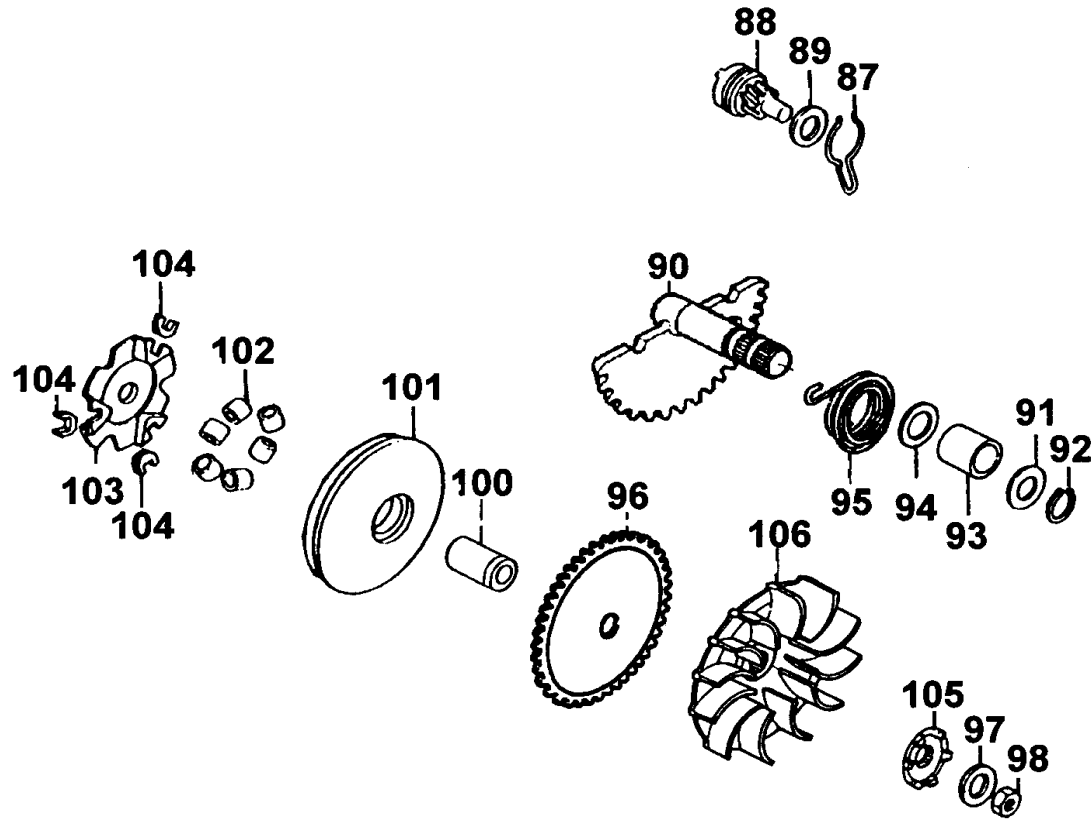

販賣記號 Sales mark	項目 Ref no	零件號碼 Part no	版數 Ver	英文名稱 Description	中文名稱 Chinese	需要用量 Regd no	參考價 Ref Price
*	87	28223-KBN-9010	0	SPG KICK DRIVEN GEAR	起動惰齒輪彈簧	1	
*	88	28230-GAK-9210	0	GEAR COMP KICK DRIVEN	起動惰齒輪組	1	
*	89	90412-329-0010	0	WASHER THRUST 10M/M	華司	1	
*	90	28250-KCC-9000	0	SPINDLE COMP KICK STARTER	起動臂軸	1	
*	91	90451-GN2-6010	0	WASHER KICK SPINDLE	華司	1	
*	92	94511-14000	0	CIRCLIP EX 14	夾環	1	
*	93	28253-GN2-6020-M1	0	BUSH KICK SPINDLE	起動臂軸襯套	1	
*	94	28255-GS6-0010	0	COLLAR KICK BOSS	套筒	1	
*	95	28281-GN2-6030-M1	0	SPRING KICK RETURN	起動彈簧	1	
*	96	22102-KEB7-9000	0	FACE DRIVE	驅動皮帶扇葉盤	1	
*	97	90426-KBN-9010	0	WASHER SPECIAL 12MM	華司	1	
*	98	94001-12200-0S	0	NUT HEX 12MM	螺帽	1	
*	100	22105-KEB7-E000	0	BOSS DRIVE FACE	滑動式驅動盤襯套	1	
*	101	22110-GR1-8810	0	FACE COMP MOVABLE DRIVE	滑動式驅動盤	1	
*	102	22121-GW0-9010	0	ROLLER COMP WEIGHT 8.5 gr	配重滾子	6	
*	103	22131-GAH-7810	0	PLATE RAMP	斜坡板	1	
*	104	22132-GW0-0010	1	PIECE SLIDE	斜板邊件	3	
*	105	28211-KEB7-9000	0	RATCHET KICK STARTER	起動齒盤	1	
*	106	22103-KEB7-9000	0	FAN CVT COOLING	冷卻風扇	1	

E 7 Driven Pulley

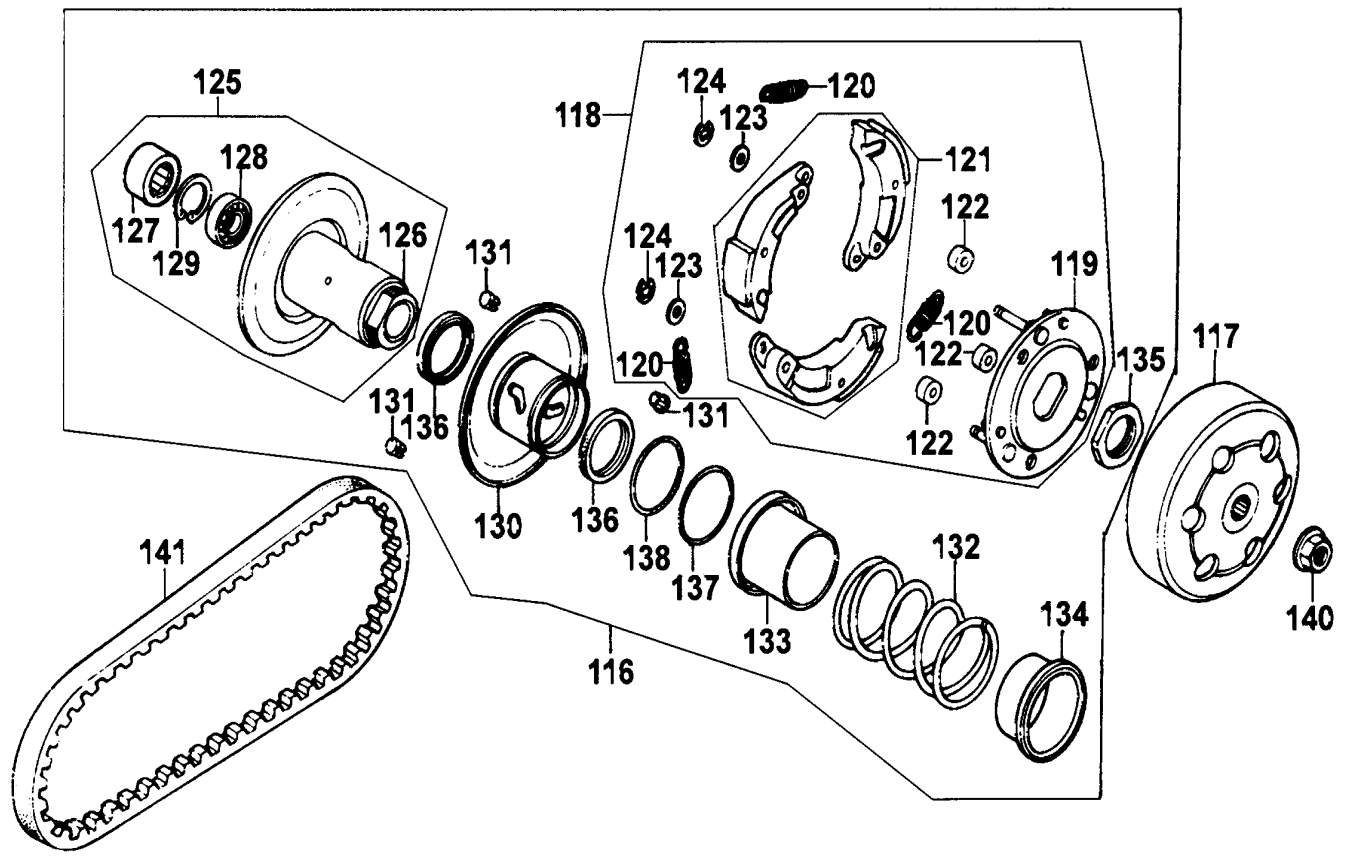

販賣記號 Sales mark	項目 Ref no	零件號碼 Part no	版數 Ver	英文名稱 Description	中文名稱 Chinese	需要用量 Regd no	參考價 Ref Price
*	116	2301A-KEB7-9000	1	PULLEY SUB ASSY	從動皮帶輪組	1	
*	117	22100-GR1-7510	0	CLUTCH OUTER	離合器外套	1	
*	118	22300-KCX-9000	0	PLATE ASSY DRIVE	驅動板組	1	
	119	22350-GAK-9300	1	PLATE COMP DRIVE	驅動板	1	
*	120	22401-GG2-9000	0	SPRING CLUTCH	離合器彈簧	3	
	121	22530-GAK-9300	1	WEIGHT SET CLUTCH	離合配重	1	
*	122	22804-148-0010	0	RUBBER CLUTCH DUMPER	橡皮	3	
	123	90442-044-0000	0	6M/M THRUST WASHER	華司	3	
	124	90454-GB2-0000	0	CIRCLIP 6MM	環夾	3	
*	125	23200-GR1-7510	0	FACE ASSY DRIVEN	平面轉動組	1	
*	126	23210-GR1-7510	0	FACE COMP DRIVEN H1	平面轉動組	1	
*	127	91103-GR1-0040	0	BRG NEEDLE 17*25*18 WS	滾針軸承	1	
*	128	91001-GA7-7020-M1	0	BRG RADIAL BALL 6901U	軸承	1	
*	129	94520-24000	0	CIR CLIP IN 24	夾環	1	
*	130	23220-GAK-2200	0	FACE COMP MOVABLE DRIVEN	滑動式從動皮帶盤	1	
*	131	23225-GR1-7510	0	PIN GUIDE	導銷	3	
*	132	23233-GE8-0000	1	SPG DRIVEN FACE	驅動彈簧	1	
*	133	23237-GR1-8810	0	COLLAR SEAL	套筒油封	1	
*	134	23238-GY6-9410	0	COLLAR SPG	套筒	1	
*	135	90202-187-0010	0	NUT SPECIAL 28MM	螺帽	1	

E 7 Driven Pulley

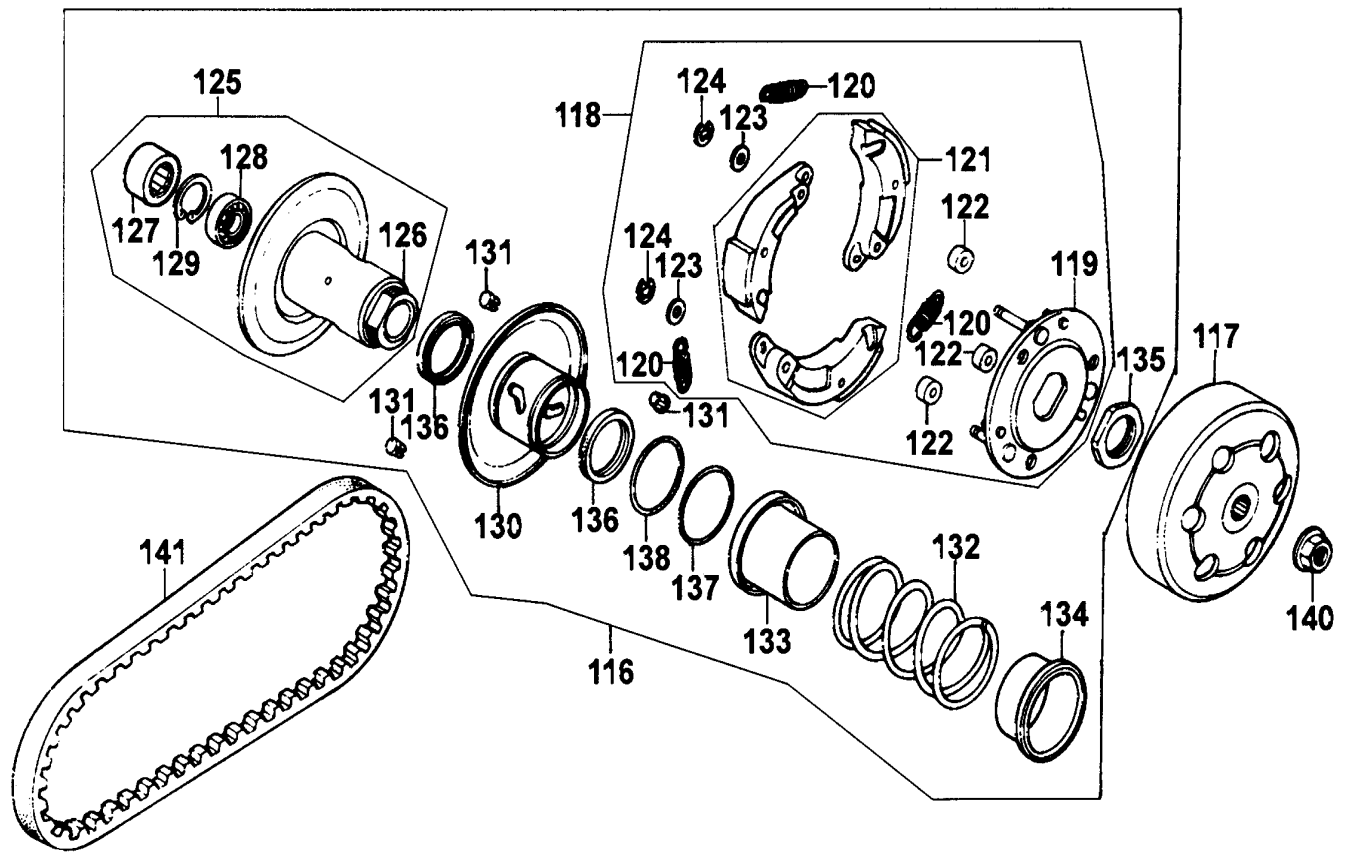

販賣記號 Sales mark	項目 Ref no	零件號碼 Part no	版數 Ver	英 文 名 稱 Description	中 文 名 稱 Chinese	需要用量 Regd no	參考價 Ref Price
*	136	91211-GK8-0130	0	OIL SEAL 34*39*3	驅動油封	2	
*	137	91301-KA5-7420-Y1	0	O-RING 36*1.5	O環	1	
*	138	91302-PA9-0040	0	O-RING 39.8*2.2	O環	1	
*	140	94050-10080	0	NUT FLANGE 10MM	螺帽	1	
*	141	23100-KEB7-9000	0	BELT DRIVE	驅動皮帶	1	

E 8 Transmission

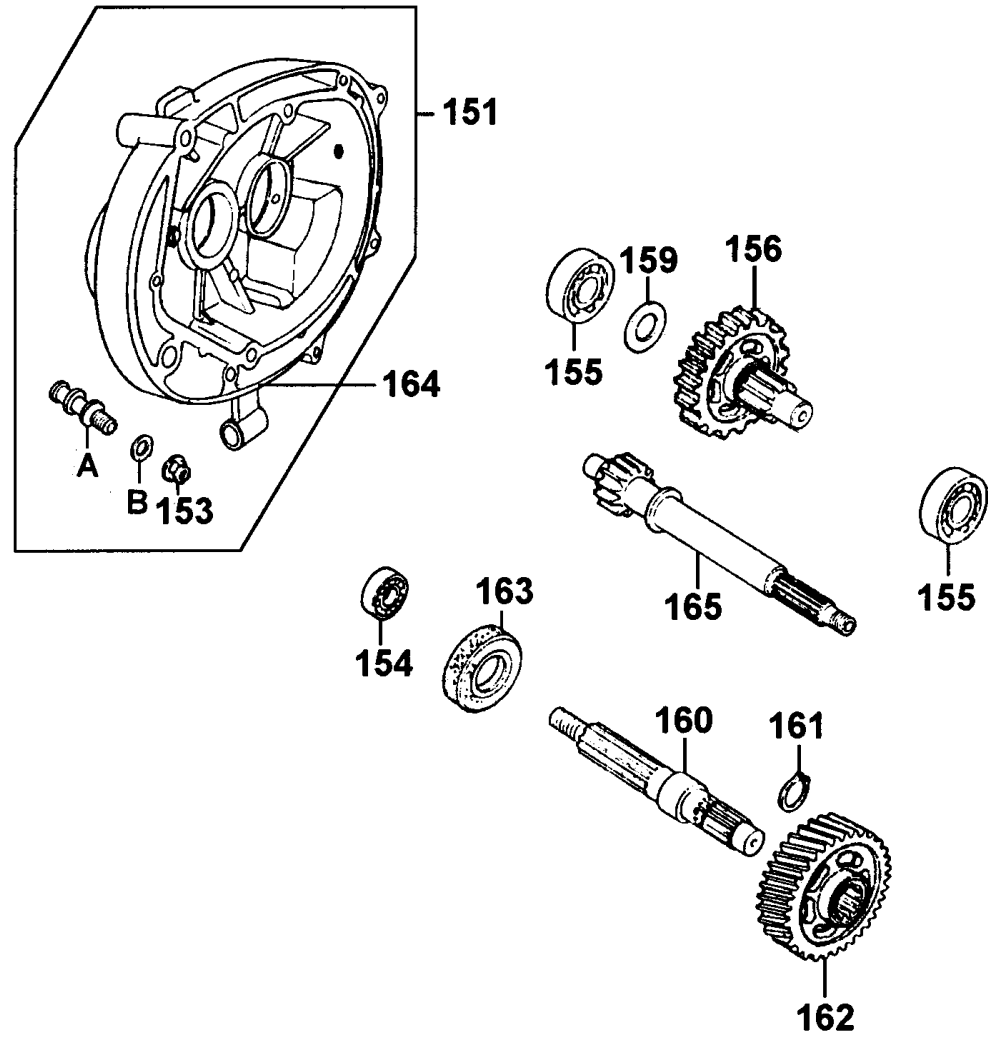

販賣記號 Sales mark	項目 Ref no	零件號碼 Part no	版數 Ver	英文名稱 Description	中文名稱 Chinese	需要用量 Regd no	參考價 Ref Price
*	151	21200-KFA6-3050	0	CASE ASSY MISSION	變速箱蓋	1	
*	153	90309-KF0-0030	1	NUT FLANGE 8MM	平螺帽	1	
*	154	91009-GE0-0040	0	BRG BALL RADIAL 6004 UU	軸承	1	
*	155	91004-KN2-9020-M1	0	BRG BALL RADIAL 6201	軸承	2	
*	156	23420-KFA6-9000	0	SHAFT COMP COUNTER	副軸組	1	
*	159	90429-KBN-9010	0	WASHER SIDE 12MM	華司	1	
*	160	23431-KBN-9010-H1	1	SHAFT FINAL	最終軸	1	
*	161	94510-20000	0	CIR CLIP EX 20	夾環	1	
*	162	23432-KFA6-9000	0	GEAR FINAL	最終齒輪	1	
*	163	91255-GE0-0060	0	OIL SEAL 27*42*7	油封	1	
*	164	21395-KFA6-9000	0	GASKET MISSION CASE A	主軸蓋墊片	1	
*	165	23411-KFA6-9000	0	SHAFT DRIVE	驅動軸	1	
*	A	11203-KDU-9000	0	PIN BRAKE SHOE ANCHOR	煞車鼓固定銷	1	
*	B	91301-053-0010	0	O RING 7.5*1.5	O環	1	

販賣記號 Sales mark	項目 Ref no	零件號碼 Part no	版數 Ver	英文名稱 Description	中文名稱 Chinese	需要用量 Regd no	參考價 Ref Price
*	170	11100-KEB7-3250	4	CRANK CASE ASSY RIGHT	右曲軸箱組	1	
	171	11100-KEB7-9000	4	CRANK CASE COMP RIGHT	右曲軸箱組	1	
*	172	11205-KED5-9000-H1	0	BUSH M STAND	襯套	2	
*	173	11102-187-0030	3	RUB BUSH ENG HANGER	引擎吊架襯套	2	
*	174	91001-GW0-9020-M1	3	BRG BALL RADIAL 6204 SPECIAL	軸承	1	
*	175	91201-KBN-9220-M1	0	OIL SEAL 15.6*25.5*7	油封	1	
*	176	94301-10200	0	DOWEL PIN 10*20	插銷	6	
*	177	96001-06045-08	0	BOLT FLANGE SH 6*45	螺栓	3	
*	178	96001-06055-08	0	BOLT FLANGE SH 6*55	螺栓	3	
*	180	11200-KFA6-3050	0	CRANK CASE ASSY L	左曲軸箱組	1	
*	181	11205-GAH-0040-H1	0	BUSH 8*12*8	襯套	1	
*	182	11204-KEB7-9000-H1	0	PIN SPG HOOK UNDER RUBBER BUSH REAR	固定銷	1	
*	183	11203-GC7-3010	2	CUSHION	後緩衝下襯套	1	
*	184	91006-KBN-9010	1	BRG BALL RADIAL 25*56*12	軸承	1	
*	185	96100-62033-00	0	BEARING BALL RADIAL 6203	徑向滾珠軸承	1	
*	186	91004-KN2-9020-M1	0	BRG BALL RADIAL 6201	軸承	1	
*	189	91004-KBN-220-M1	0	BRG BALL RADIAL 6203SPC	軸承	1	
*	192	90474-333-0010	0	WASHER 8MM	華司	1	
*	193	91202-KBN-9220-M1	0	OIL SEAL 20*31*7	油封	1	
*	194	91204-KBN-9020-M1	1	OIL SEAL 17*30*6	油封	1	

E 9 Crankcase Oil Pump

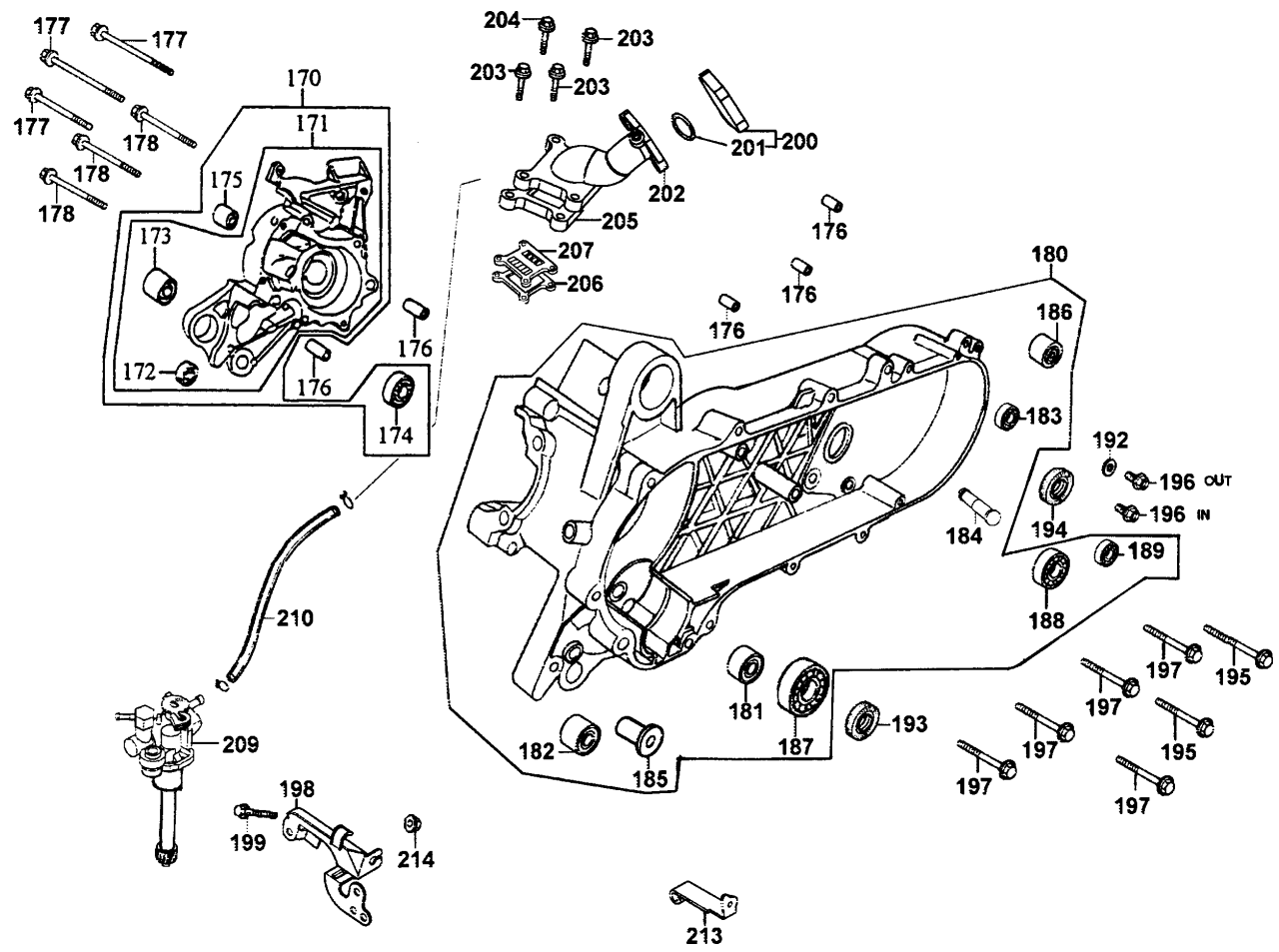

販賣記號 Sales mark	項目 Ref no	零件號碼 Part no	版數 Ver	英文名稱 Description	中文名稱 Chinese	需要用量 Regd no	參考價 Ref Price
*	195	95701-08035-08	0	BOLT FLANGE 8*35	螺絲	2	
*	196	95701-08012-08	0	BOLT FLANGE 8*12	螺絲 8*12	2	
*	197	95701-08040-08	0	BOLT FLANGE 8*40	螺絲	5	
*	198	15110-KEB7-9000	0	PLATE OIL PUMP SET	機油泵支架	1	
*	199	96001-06032-08	0	BOLT FLANGE SH 6*32	螺栓	1	
*	200	1621A-GAK-9010	0	INSULATOR CARB ASSY	絕緣器	1	
*	201	91304-GB0-9110	1	O RING 20.6*1.9	O環	1	
*	202	17100-KEB7-9010	0	PIPE COMP INLET	進氣管	1	
*	203	96001-06025-08	0	BOLT FLANGE SH 6*25	螺栓	3	
*	204	90120-GR1-J000	0	SOCKET BOLT SPECIAL 6*28	螺栓	1	
*	205	17111-KEB7-9000	0	GASKET INLET PIPE A	進氣管墊片	1	
*	206	17112-KEB7-9000	0	GASKET INLET PIPE B	簧片閥門墊片	1	
*	207	14100-KEB7-9000	0	VALVE COMP REED	簧片閥門	1	
*	209	15100-GAK-9500	13	PUMP ASSY OIL	機油泵浦組	1	
*	210	1552A-KEB8-9000	0	TUBE ASSY OIL PASS	噴合油管組	1	
*	213	11208-GAK-9010	0	CLAMPER CARB DRAIN	管夾	1	
*	214	94050-06080	0	NUT FLANGE 6MM	螺帽	1	

E 10 Crank Shaft●Piston

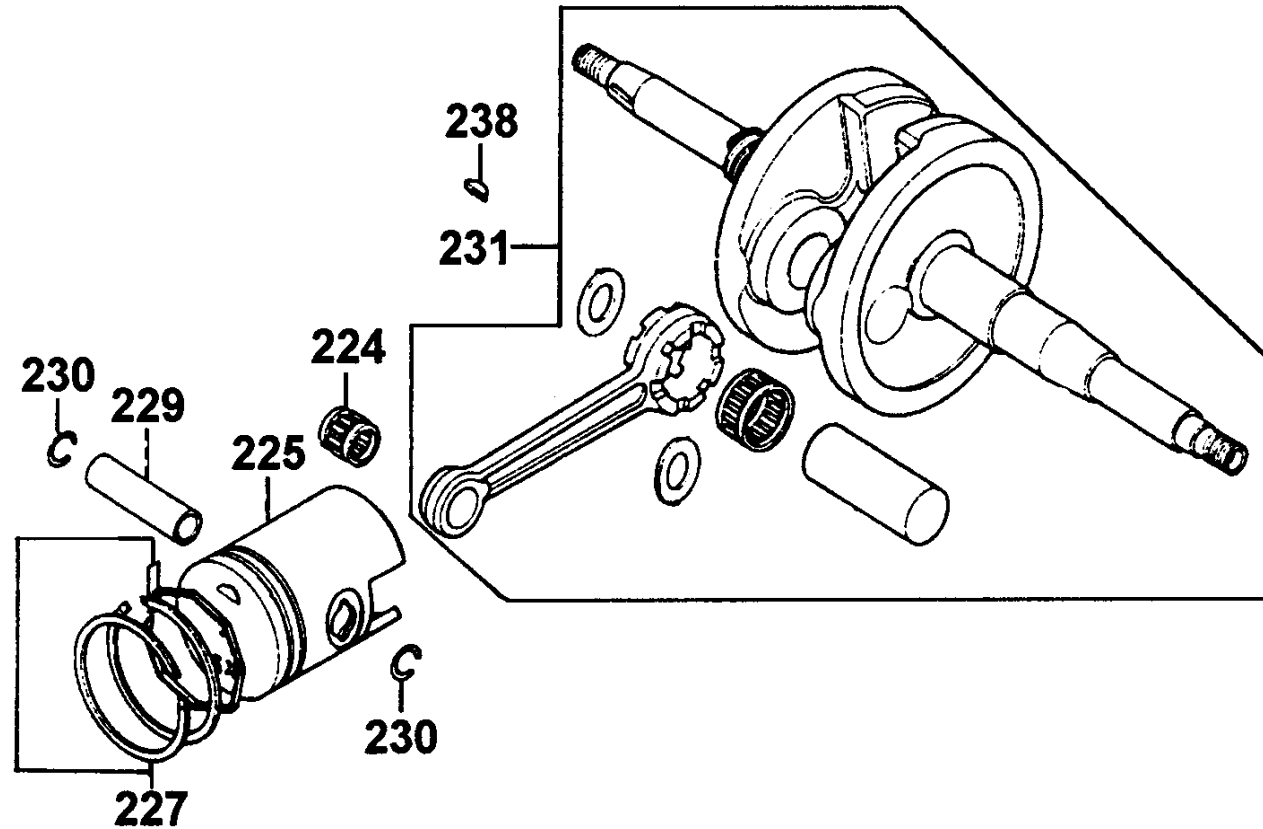

販賣記號 Sales mark	項目 Ref no	零件號碼 Part no	版數 Ver	英 文 名 稱 Description	中 文 名 稱 Chinese	需要用量 Regd no	參考價 Ref Price
*	224	91102-GW0-0090	0	BRG CON-ROD S. E.	連桿小端軸承	1	
*	225	13101-GW-9010	1	PISTON	活塞	1	
*	227	13011-GAK-9120-M1	0	RING ASSY PISTON 2ND	活塞環組	1	
*	229	13111-166-0010	1	PIN PISTON	活塞銷	1	
*	230	13115-156-0010	0	CLIP PISTON PIN 12MM	活塞銷夾	2	
*	231	13000-GAK-9210	5	CRANK SHAFT COMP	曲軸	1	
*	238	90741-035-0010	0	KEY WOODRUFF	固定鍵	1	

E 11 Carburetor

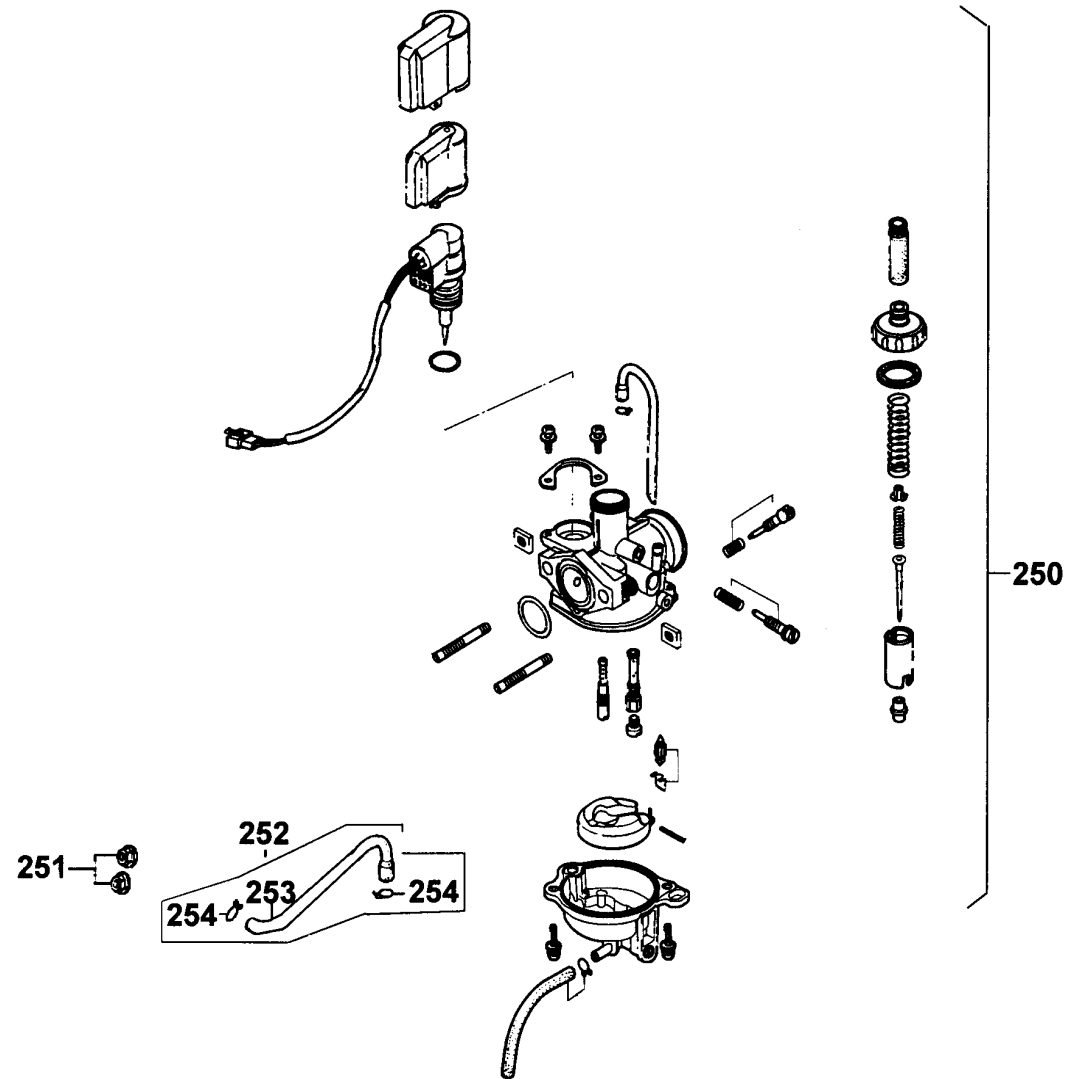

販賣記號 Sales mark	項目 Ref no	零件號碼 Part no	版數 Ver	英文名稱 Description	中文名稱 Chinese	需要用量 Regd no	參考價 Ref Price
*	1	D19KT-006-0300	0	VALVE PLATE SET	阻板	1	
*	2	D19KT-001-0800	0	ARM PIN	浮筒閥臂銷	1	
*	3	D19KT-001-1800	0	SET PLATE	固定板	1	
*	4	D19KT-006-2000	0	HOLDER CAP	自動起動閥蓋	1	
*	6	D19KT-001-3800	0	STUD BOLT	雙頭螺絲	2	
*	7	D19KT-001-3900	0	HEX NUT	螺帽	2	
*	8	D19KT-003-0700	0	FLOAT VALVE SET	浮筒閥	1	
*	9	D19KT-003-1500	0	O-RING	O環	1	
*	10	D19KT-015-1600	0	SCREW SET (S.S)	螺絲組	1	
*	11	D19KT-037-0200	0	SPG COMPR	彈簧	1	
*	12	D19KT-074-2100	0	TUBE SET	空氣管	1	
*	13	D19KT-003-1300	0	FLOAT COMP	浮筒組	1	
*	14	D19KT-005-1900	0	SCREW WASHER	螺絲	2	
*	15	D19KT-006-1900	0	SCREW WASHER	螺絲	2	
*	16	D19KT-024-0110	0	TOP SET	節流活塞閥蓋	1	
*	17	D19KT-042-0900	0	NEEDLE JET HOLDER	噴針座	1	
*	18	D19KT-005-1000	0	MAIN JET #82	主噴油針 #82	1	
*	19	D19KT-056-0600	0	NEEDLE JET	油針座	1	
*	20	D19KT-033-1400	0	SCREW SET	螺絲組	1	
*	21	D19KT-044-0500	0	THROTTLE VALVE	節流活塞閥	1	

E 11 Carburetor

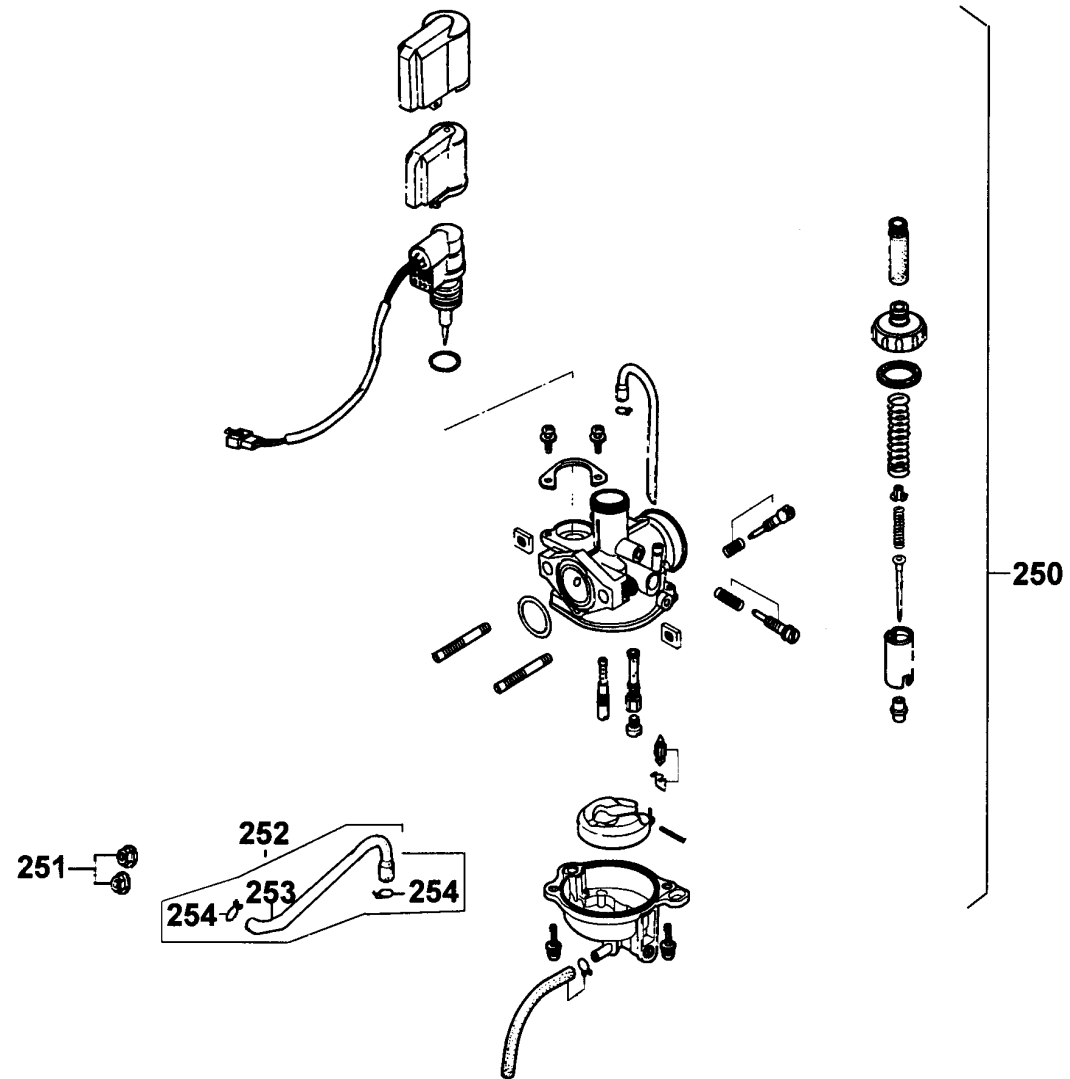

販賣記號 Sales mark	項目 Ref no	零件號碼 Part no	版數 Ver	英 文 名 稱 Description	中 文 名 稱 Chinese	需要用量 Regd no	參考價 Ref Price
*	22	D19KT-031-1100	0	SLOW JET	慢速噴油嘴	1	
*	23	D19KT-046-1200	0	FLOAT CHAMBER SET	浮筒室組	1	
*	24	D19KT-046-1700	0	AUTO BYSTARTER SET	自動旁通器組	1	
*	25	D19KT-076-0400	0	JET NEEDLE COMP	油針	1	
*	26	D19KT-066-2100	0	TUBE SET	溢流管	1	
*	250	1610K-KFA6-E130-IT	1	CARBURETOR ASSY	化油器	1	
*	251	94050-06080	0	NUT FLANGE 6MM	螺帽	2	
*	A	95002-02070	0	CLIP TUBE B7	管夾	1	
*	B	95002-02080	0	CLIP TUBE B8	管夾	1	

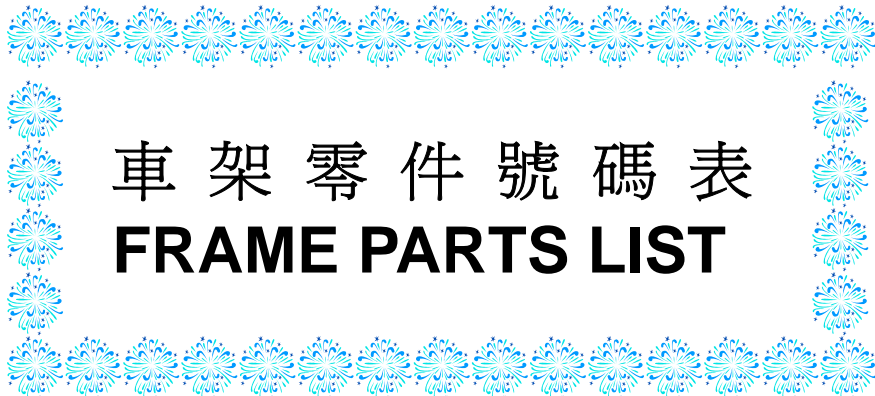

車架零件號碼表
FRAME PARTS LIST

F 1 Head Light

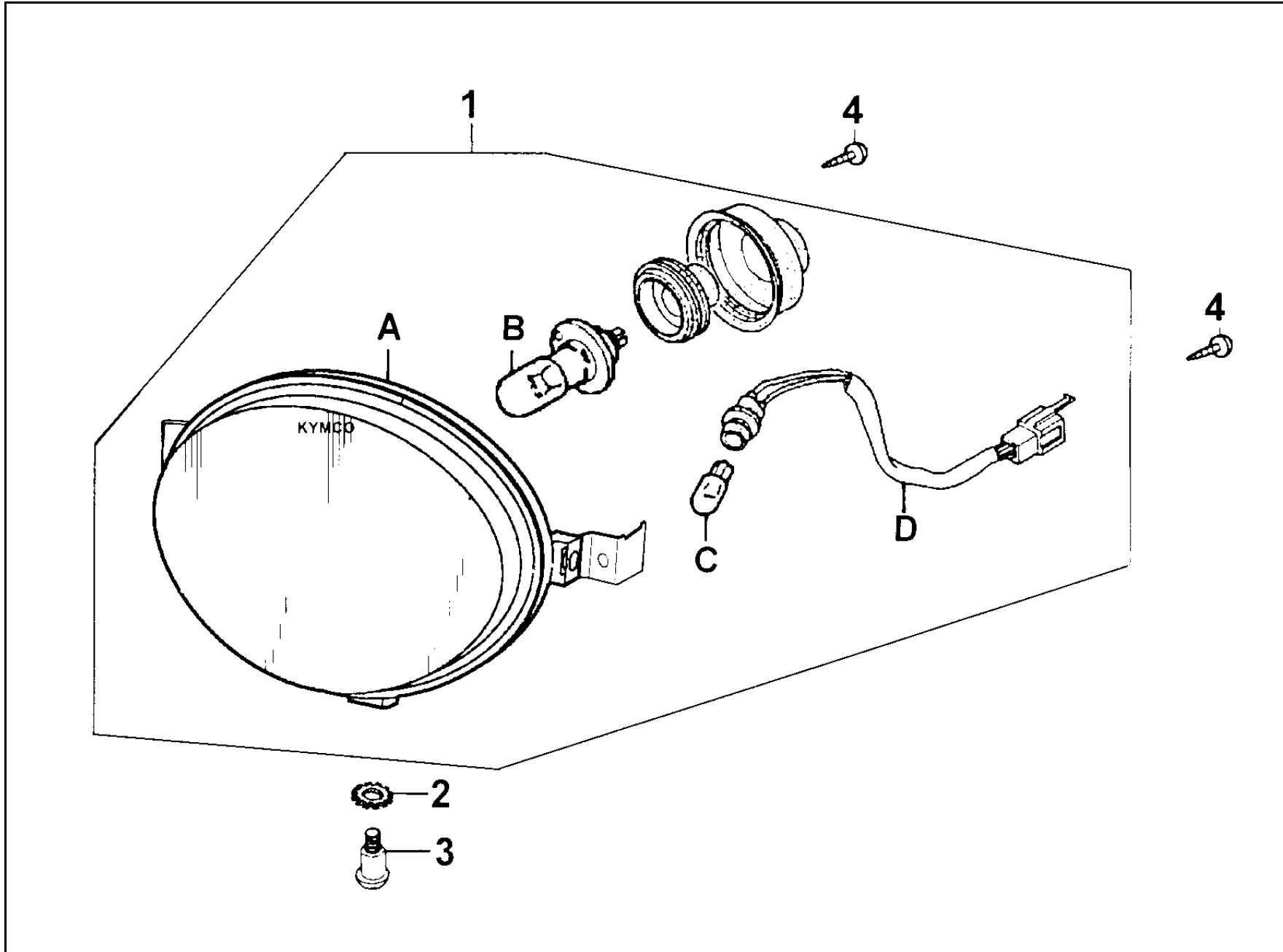

F 1

販賣記號 Sales mark	項目 Ref no	零件號碼 Part no	版數 Ver	英文名稱 Description	中文名稱 Chinese	需要用量 Regd no	參考價 Ref Price
*	1	33100-KFA6-9000	0	LIGHT ASSY HEAD	前燈組	1	
*	2	90307-GJ6-0040	0	WASHER LOCK 6MM	華司	1	
*	3	90101-GR1-0010	0	BOLT ADJUST	螺絲	1	
*	4	93903-35220	0	SCREW TAPPING 5*12	螺釘	3	
*	A	33120-KFA6-9000	0	UNIT HEAD LIGHT	前燈殼	1	
*	B	34901-KFA6-9000	0	BULB HEAD LIGHT	前燈泡	1	
*	C	34903-KCP-9000	0	BULB POSITION	位置燈泡	1	
*	D	33130-KFA6-9000	0	SOCKET COMP	前燈配線	1	

F 2 Speedometer

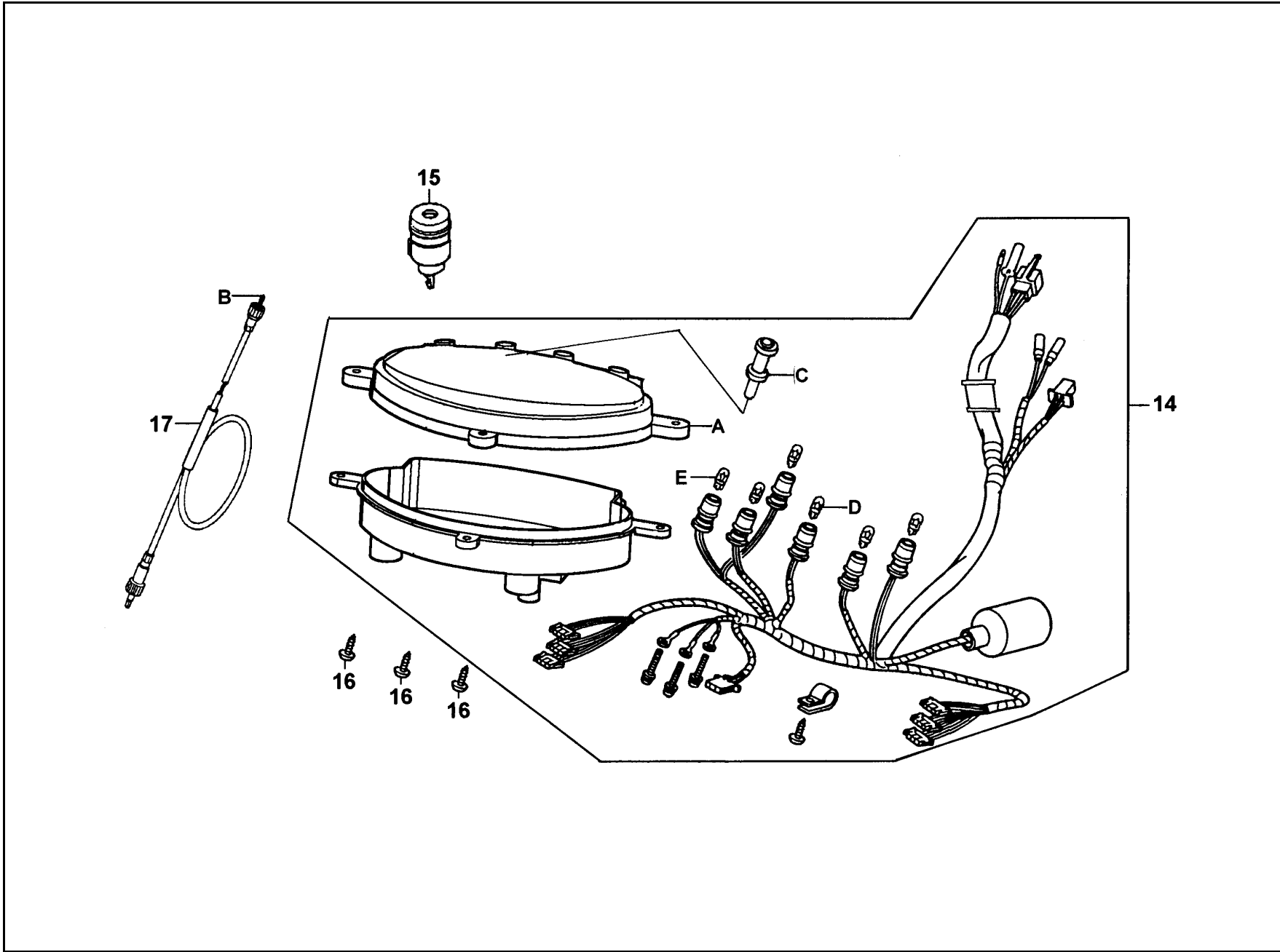

販賣記號 Sales mark	項目 Ref no	零件號碼 Part no	版數 Ver	英文名稱 Description	中文名稱 Chinese	需要用量 Regd no	參考價 Ref Price
*	14	37200-KFA6-E000-FL-M1	0	METER ASSY SPEED	儀錶組	1	
*	14	37200-KFA6-E000-FL-M2	0	METER ASSY SPEED	儀錶組	1	
*	15	38300-KCE-9000	1	RELAY ASSY WINKER	方向燈繼電器	1	
*	16	93903-35320	0	SCREW TAPPING 5*16	螺釘 5*16	3	
*	17	44830-KFA6-9000	0	CABLE COMP SPDMT	速度錶導線	1	
*	A	37211-KFA6-9000-M1	0	LENS ASSY	儀錶蓋	1	
*	A	37211-KFA6-9000-M2	0	LENS ASSY	儀錶蓋	1	
*	B	44831-KFA6-9000	0	CABLE INNER	速度錶內導線	1	
*	C	37213-KFA6-9000-M1	0	PACKING	碼錶電子鐘按鈕	2	
*	D	34908-GA7-7010-M1	1	BULB WEDGE BASE	儀錶內燈泡	2	
*	E	34908-MB9-8710-M1	0	BULB WEDGE BASE	儀錶內燈泡	4	

F 3 Handle Steering ● Handle Cover

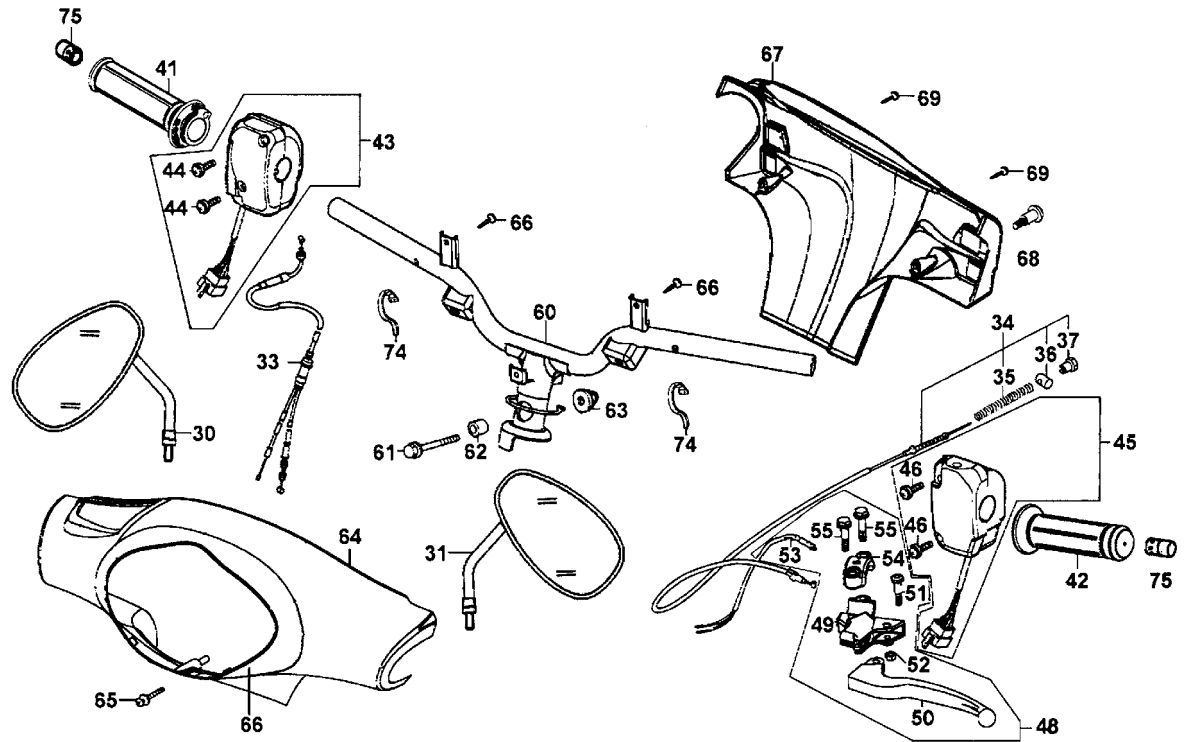

販賣記號	項目	零件號碼	版數	英文名稱	中文名稱	需要用量	參考價
Sales mark	Ref no	Part no	Ver	Description	Chinese	Regd no	Ref Price
*	30	88110-KFA6-9000	1	MIRROR ASSY R BACK	右後視鏡	1	
*	31	88120-KFA6-9000	1	MIRROR ASSY L BACK	左後視鏡	1	
*	33	17910-KFA6-9000	0	CABLE COMP THROT	節流導線	1	
*	34	43450-KFA6-9000	1	CABLE COMP RR BRK	後煞車導線	1	
*	35	43472-161-0000	1	SPG RR BRK ARM	煞車彈簧	1	
*	36	95015-32001	0	JOINT B BRAKE ARM	煞車臂連結器	1	
*	37	95015-42000	0	NUT B ADJUST	煞車間繫調整螺帽	1	
**	41	53140-KBN-9600	0	GRIP COMP THROT	節流管套組	1	
**	42	53166-KBN-9100	0	GRIP L HANDLE	手柄左橡皮套	1	
*	43	3515A-KGBG-E000	2	SW ASSY RH HNDL COMP	手柄右邊開關組	1	
*	44	93500-KGBG-9000	0	SCREW TAPPING M 5*25L	螺絲	2	
*	45	3520A-KGBG-E000	2	SW ASSY LH HNDL COMP	手柄左邊開關組	1	
*	46	93500-KGBG-9000	0	SCREW TAPPING M 5*25L	螺絲	2	
*	48	5317B-KFA6-9000	0	BRKT ASSY HNDL L	手煞車拉桿	1	
*	49	53172-KCT-9000	0	BRKT HNDL L	左拉桿托架	1	
*	50	53178-KFA6-9000	0	LEVER L STRG HNDL	左拉桿	1	
*	51	90115-GE0-0010	0	BOLT HNDL LEVER PIVOT	拉桿螺絲	1	
*	52	94001-05080-0S	0	NUT HEX 5MM	螺帽	1	
*	53	35340-KJ9-0100	4	SW ASSY FR STOP	剎車燈前置開關組	1	
*	54	45517-GY6-9000	4	HOLDER HNDL BRKT	手柄固定座夾板	1	

F 3 Handle Steering ● Handle Cover

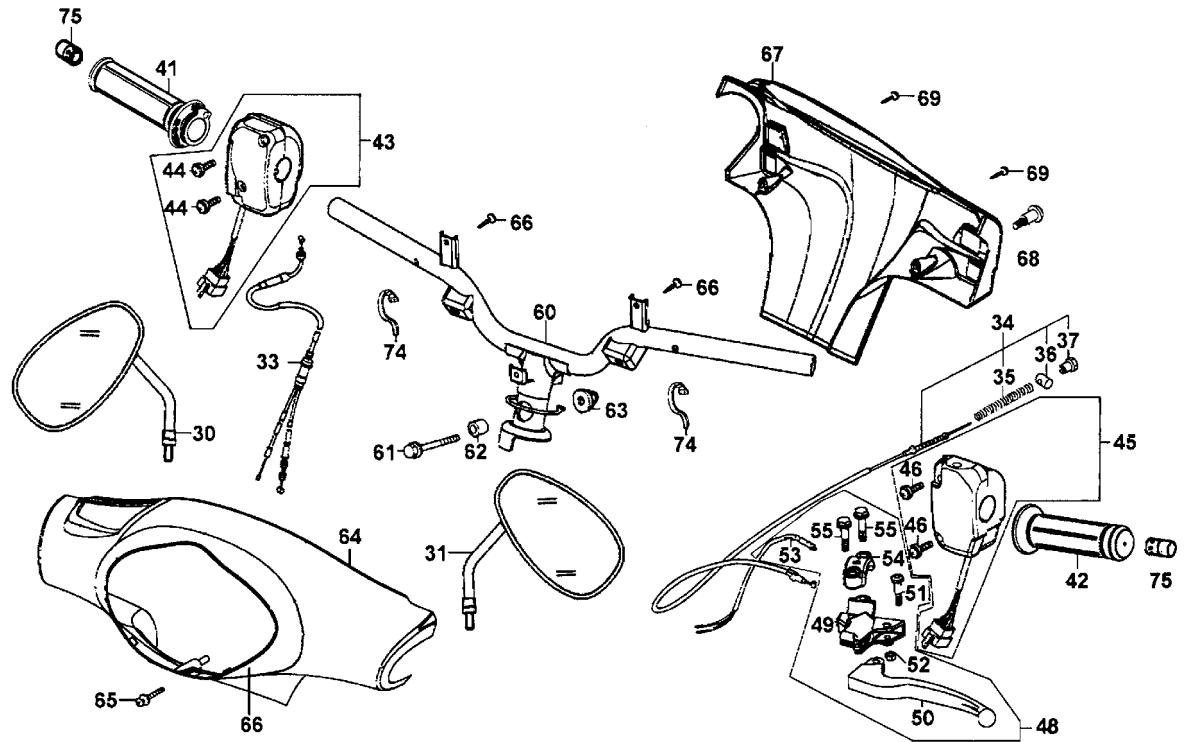

販賣記號	項目	零件號碼	版數	英文名稱	中文名稱	需要用量	參考價
Sales mark	Ref no	Part no	Ver	Description	Chinese	Regd no	Ref Price
*	55	96001-06025-07	0	BOLT FLANGE 6*25	螺絲	2	
*	60	53100-KHB4-9000	0	HANDLE COMP STRG	轉向手柄	1	
*	61	90106-GN5-9010	0	BOLT FLANGE 10*50	特殊螺絲	1	
*	62	53125-GN5-9010	0	COLLAR HANDLE SET	套筒	1	
*	63	90304-GE8-0030	1	NUT U 10MM	螺帽	1	
**	64	53205-KFA6-E000	0	COVER FR HANDLE	手柄前蓋	1	
*	65	93891-05030-07	0	SCREW WASHER 5*30	螺絲	1	
*	66	53204-KFA6-9000	0	COVER HEAD LIGHT	前燈蓋	1	
**	67	53206-KFA6-9000	1	COVER RR HANDLE	手柄後蓋	1	
*	68	90302-KBN-9000	0	BOLT PAN 5*10	螺絲	1	
*	69	93903-34380	0	SCREW TAPPING 4*12	螺釘	2	
*	74	90656-GY6-9110	0	BAND OIL HOSE	油管束帶	3	
*	75	53105-KBN-9100	0	END STRG HANDLE	手柄平衡端子	2	

F 4 Brake Master Cylinder

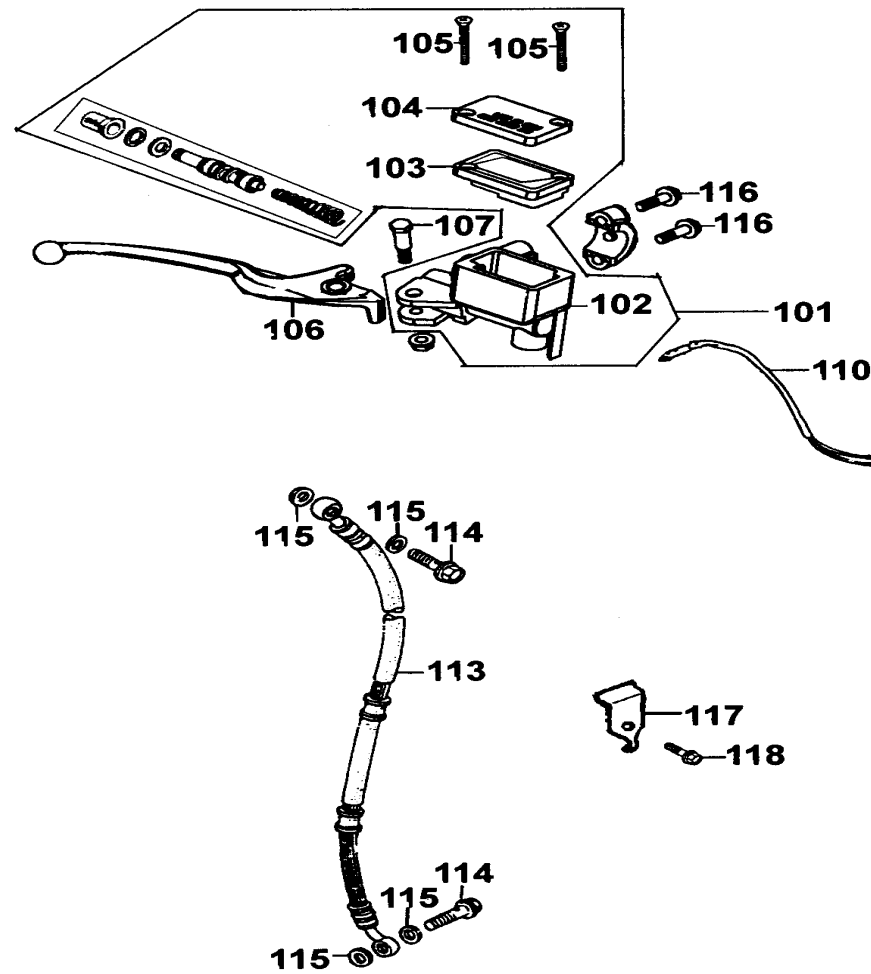

販賣記號	項目	零件號碼	版數	英文名稱	中文名稱	需要用量	參考價
Sales mark	Ref no	Part no	Ver	Description	Chinese	Regd no	Ref Price
*	101	45530-KFA6-3050	1	M/C ASSY FR	煞車油主缸	1	
*	104	45513-KFA6-9000	0	CAP M/C	煞車主油缸蓋	1	
*	105	93600-04012-1G	0	SCREW FLAT 4*12	螺絲	2	
*	106	53175-KFA6-9000	0	LEVER R STRG HNDL	手柄右拉桿	1	
*	107	90114-166-0070	1	BOLT HANDLE LEVER	右拉桿固定螺栓	1	
*	110	32101-GY6-9000	1	SUB CORD R	煞車燈開關右配線	1	
*	113	45126-KFA6-9000	0	HOSE ASSY FR BRK	前煞車油管	1	
*	114	90145-MS9-6120-M1	0	OIL BOLT 10*22	油管螺絲	2	
*	115	90545-300-0010	2	WASHER OIL BOLT	華司	4	
*	116	95701-06022-07	0	BOLT FLANGE 6*22	螺絲	2	
*	117	43452-GAK-9000	0	CLAMP BRK CABLE	導線夾	1	
*	118	96001-06012-07	0	BOLT FLANGE SH 6*12	凸緣螺栓	1	

F 5 Front Cover●Floor Panel

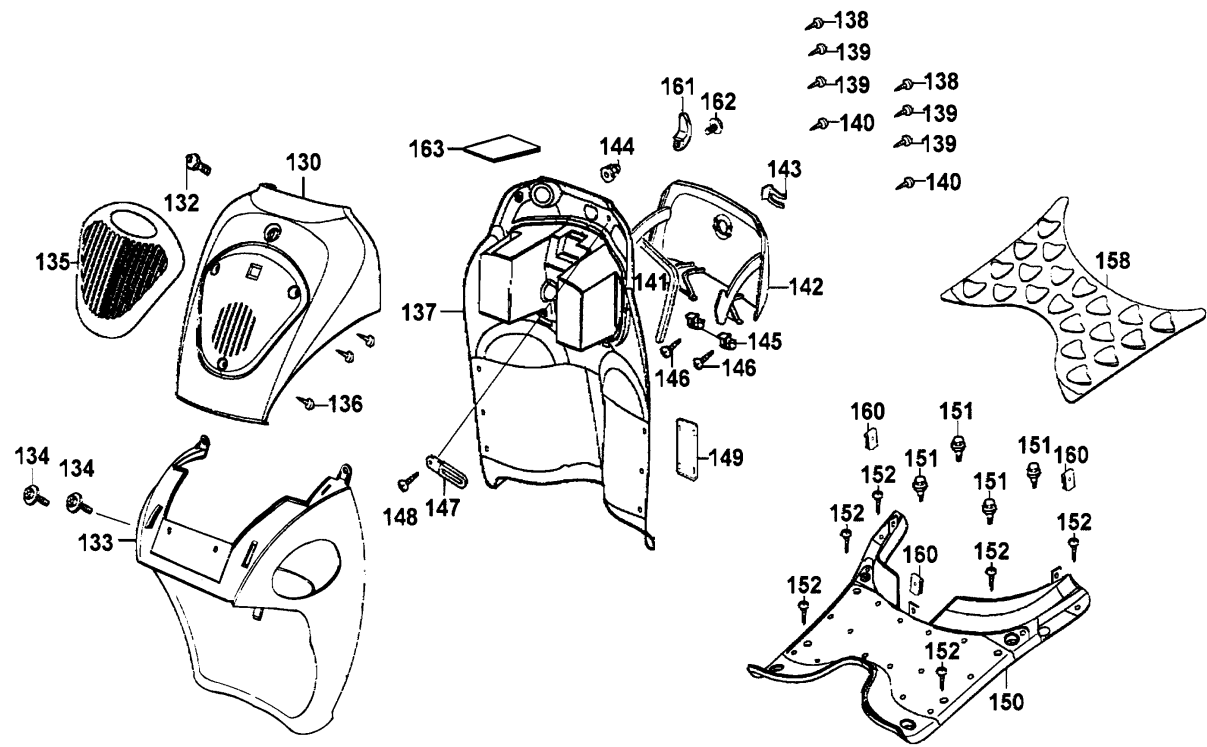

販賣記號	項目	零件號碼	版數	英文名稱	中文名稱	需要用量	參考價
Sales mark	Ref no	Part no	Ver	Description	Chinese	Regd no	Ref Price
**	130	64301-KFA6-9000	1	COVER SET FRONT	前蓋	1	
*	132	90110-GW0-0010	0	SCREW SPECIAL 6*14	螺絲	1	
**	133	64302-KFA6-9000	1	MOLD FRONT	前邊條	1	
*	134	90302-GY6-9010	0	BOLT WASHER 5*12	螺絲	2	
*	135	64303-KFA6-9000	0	GRILL FRONT COVER	前蓋飾蓋	1	
*	136	93903-34380	0	SCREW TAPPING 4*12	螺絲	2	
**	137	81131-KFA6-9000	0	LEG SHIELD	行李箱	1	
*	138	93903-34380	0	SCREW TAPPING 4*12	螺絲	2	
*	139	93903-34380	0	SCREW TAPPING 4*12	螺絲	4	
*	140	93903-34380	0	SCREW TAPPING 4*12	螺絲	2	
*	141	81146-GN2-0010	0	SEAL RUBBER A	內箱防水封	1	
**	142	81141-KFA6-9000	0	LID INNER BOX	內箱蓋	1	
*	143	75581-673-0010	0	SET SPG LOCK KET	鑰匙鎖固定彈簧	1	
*	144	90301-634-6700	0	NUT FLANGE 6MM	螺帽	2	
*	145	81142-KFA6-9000	0	STAY LID INNER BOX	導線鉤支柱	2	
*	146	93903-34380	0	SCREW TAPPING 4*12	螺絲	1	
*	147	94591-27000	0	CLIP 2*70	夾	1	
*	148	93903-34380	0	SCREW TAPPING 4*12	螺絲	2	
**	149	81132-KFA6-9000	0	LID LEG SHIELD	內箱蓋	1	
**	150	64310-KFA6-9000	2	FLOOR PANEL	腳踏板	1	

F 5 Front Cover●Floor Panel

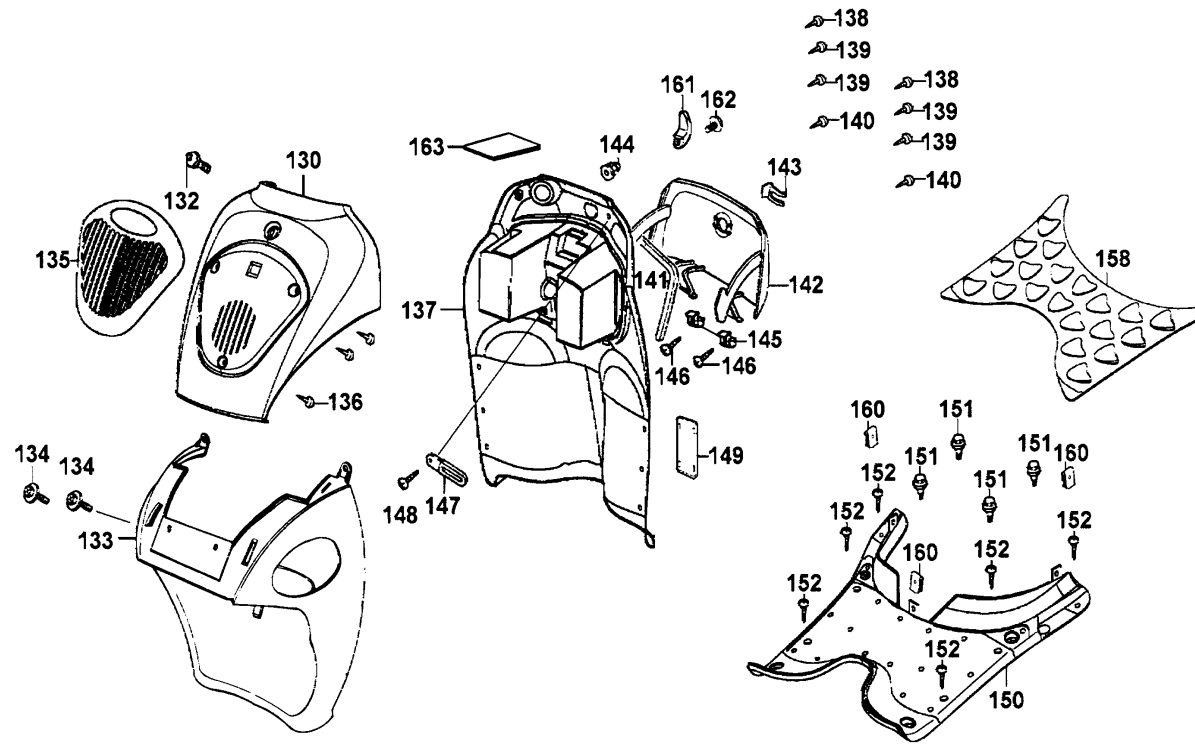

F 5

販賣記號	項目	零件號碼	版數	英文名稱	中文名稱	需要用量	參考價
Sales mark	Ref no	Part no	Ver	Description	Chinese	Regd no	Ref Price
*	151	93404-06020-07	0	BOLT WASH 6*20	螺絲	4	
*	152	93903-34380	0	SCREW TAPPING 4*12	螺絲	6	
*	153	90320-692-0000	3	NUT SPRING M5	螺帽	1	
**	158	64320-KFA6-9000	0	MAT FLOOR	腳踏板墊	1	
*	160	90302-SA4-0040	1	NUT SPRING 4MM	螺帽	2	
*	163	50330-KBE-9000	0	SEAL BATTERY FR	油封	2	

F 6 Stem Steering ● Front Fork

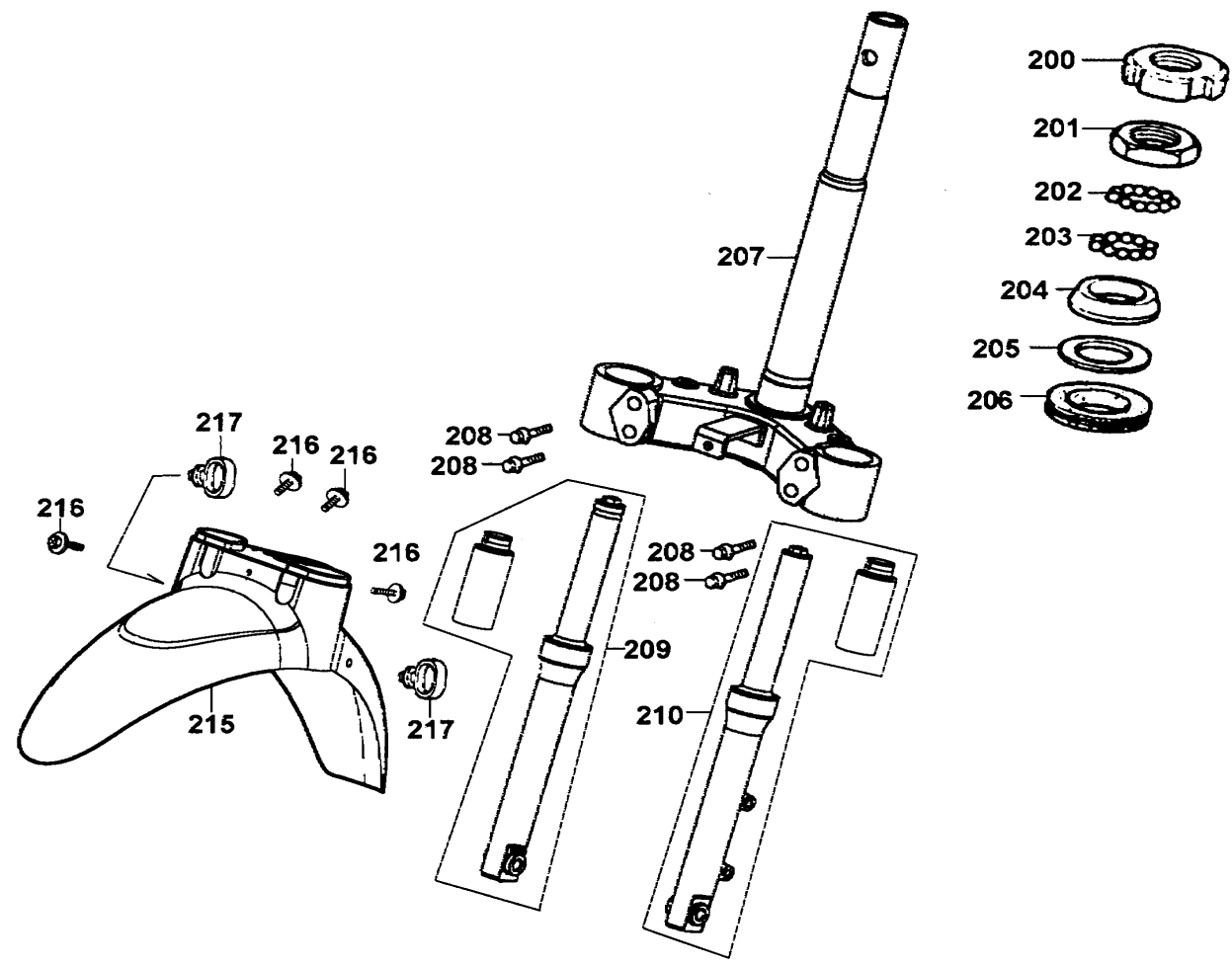

販賣記號	項目	零件號碼	版數	英文名稱	中文名稱	需要用量	參考價
Sales mark	Ref no	Part no	Ver	Description	Chinese	Regd no	Ref Price
*	200	50306-196-0010	0	NUT STRG STEM LOCK	主幹螺帽	1	
*	201	53211-GY6-9400	0	RACE STRG TOP CONE	上錐體座圈	1	
*	202	96211-05000	0	BALL STEEL 5	鋼珠	26	
*	203	96211-08000	0	BALL STEEL 8	鋼珠	19	
*	204	53212-250-0110	0	RACE STRG BOT CONE	下錐體座圈	1	
*	205	53215-250-0010	0	WASH STRG HDL DUST-SEAL	轉向桿華司	1	
*	206	53214-250-0010	0	DUST SEAL STRG(HEAD)	墊片	1	
*	207	53200-KFA6-9000	1	STEM COMP STRG	轉向桿	1	
*	208	95801-08040-08	0	BOLT FLANGE 8*40	螺絲	4	
**	209	5140A-KFA6-E000	0	FORK SET R FR	右前避震器	1	
**	210	5150A-KFA6-E000	0	FORK SET L FR	左前避震器	1	
**	215	61100-KFA6-9000	0	FENDER FR	前土除	1	
*	216	90302-GY6-9400	0	BOLT WASH 5*16	螺絲	4	
*	217	45451-471-0000	2	GROMMET WIRE	橡皮固定	2	

F 7 Front Wheel

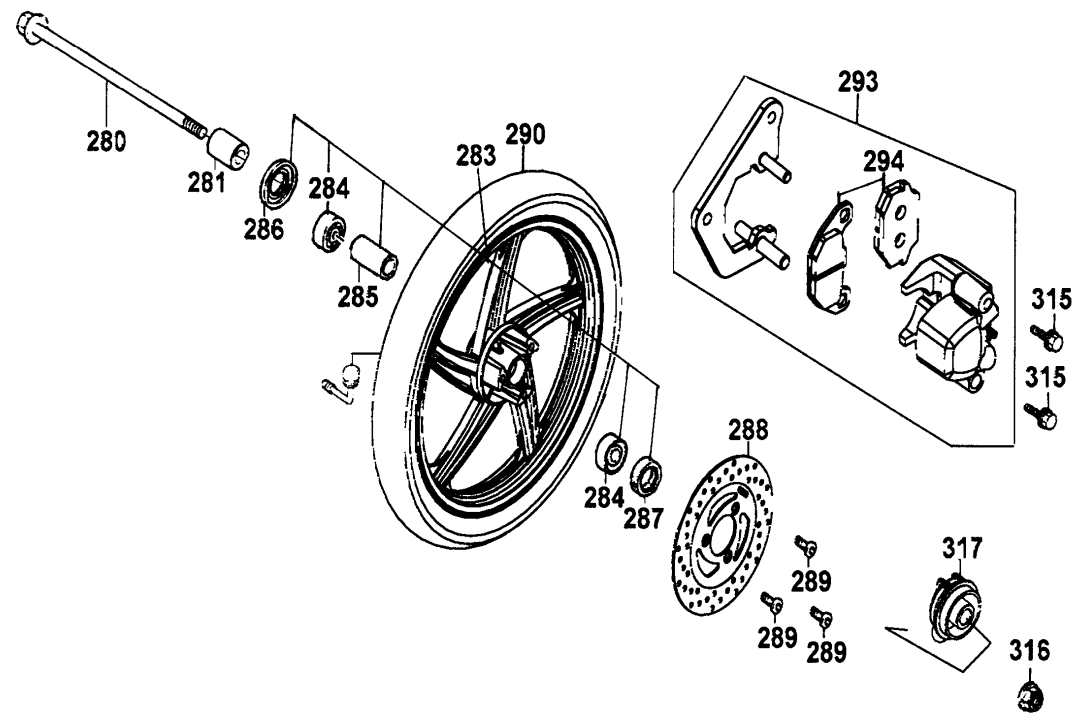

F 7

販賣記號	項目	零件號碼	版數	英文名稱	中文名稱	需要用量	參考價
Sales mark	Ref no	Part no	Ver	Description	Chinese	Regd no	Ref Price
*	280	44301-KAA-9000	1	AXLE FR WHEEL	前輪軸	1	
*	281	44311-046-0010	0	COLLAR FR WHEEL SIDE	前輪邊套筒	1	
**	283	44600-KFA6-3050	0	WHEEL SET FR	前輪圈	1	
*	284	96120-63010-10	0	BEARING BALL RADIAL 6301	軸承 6301	2	
*	285	44620-400-0000	1	COLLAR,FR DIST	前輪軸距套筒	1	
*	286	91258-410-0000-M2	0	SEAL DUST 40*50*5	油封	1	
*	287	91252-030-0000	0	OIL SEAL WHEEL 23*37*7	油封	1	
*	288	45121-KFA6-9000	0	DISK FR BRAKE	前煞車圓盤	1	
*	289	90105-KR3-0010	1	BOLT FR DISK 8*24	前煞車圓盤螺絲	3	
*	290	44710-KHB4-9000-M1	0	TIRE ASSY FR	前輪胎	1	
*	290	44710-KHB4-9000-M2	0	TIRE ASSY FR	前輪胎	1	
**	293	45200-KFA6-9000	0	CALIPER ASSY FR	前煞車卡鉗	1	
*	294	45105-KFA6-3050	0	PAD ASSY	摩擦板組	1	
*	315	90122-KBE-9000	0	BOLT FLANGE 8*32	特殊螺絲	2	
*	316	90306-GW0-9020-M1	0	NUT U FLANGE 12MM	螺帽	1	
*	317	44800-KFA6-9000	0	GEAR BOX ASSY SPDMT	速度齒輪箱組	1	

F 8 Rear Wheel

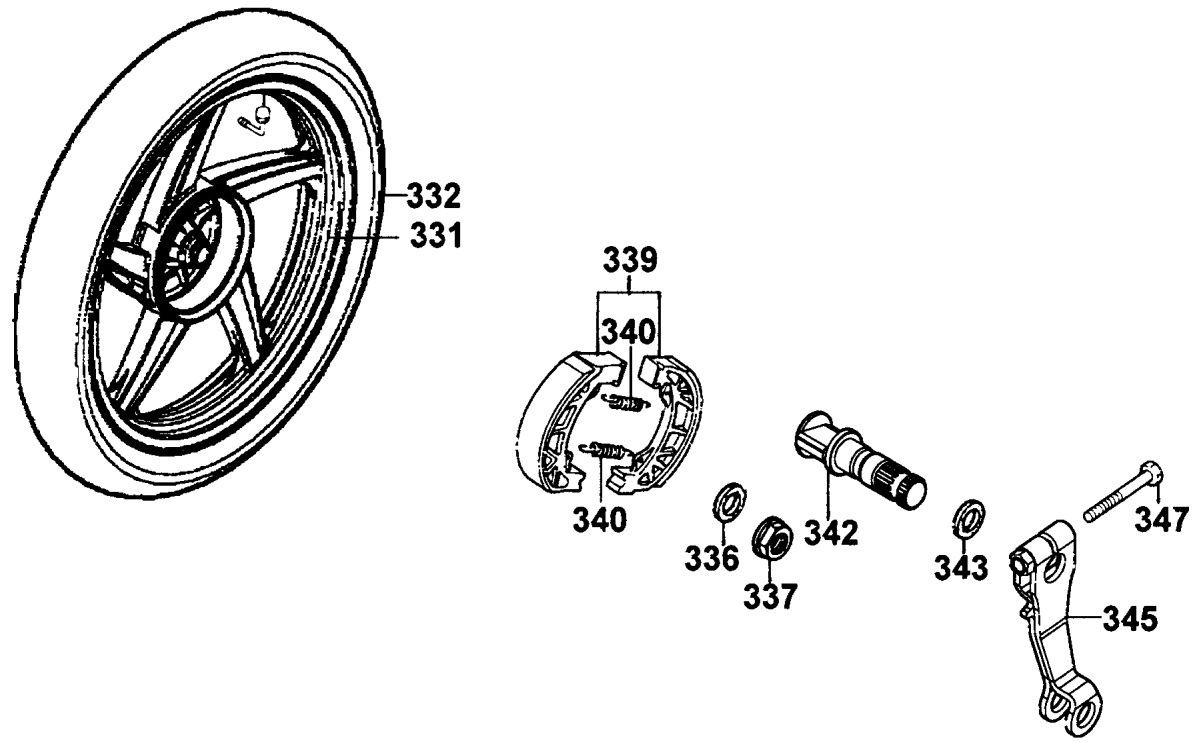

F 8

販賣記號	項目	零件號碼	版數	英文名稱	中文名稱	需要用量	參考價
Sales mark	Ref no	Part no	Ver	Description	Chinese	Regd no	Ref Price
**	331	42601-KFA6-9000	0	WHEEL COMP RR CAST	後輪殼	1	
*	332	42710-KHB4-9000-M1	0	TIRE ASSY RR	後輪胎	1	
*	332	42710-KHB4-9000-M2	0	TIRE ASSY RR	後輪胎	1	
*	336	90501-KBN-9010	0	WASHER 16MM	華司	1	
*	337	90305-KBN-9030-M2	0	NUT U 16MM	螺帽	1	
*	339	43120-KDU-9000	0	SHOE COMP RR BRAKE	後煞車鞋	2	
*	340	43151-KM7-9600	1	SPRING BRAKE SHOE	剎車鞋彈簧	2	
*	342	43141-KFA6-9000	0	CAM RR BRK	後剎車凸輪	1	
*	343	91352-KG8-8330-M2	0	O-RING 11.3*1.3	O環	1	
*	345	43410-KFA6-9000	0	ARM COMP RR BRAKE	後剎車臂	1	
*	347	95701-06032-08	0	BOLT FLANGE 6*32	螺絲	1	

F 9 Seat

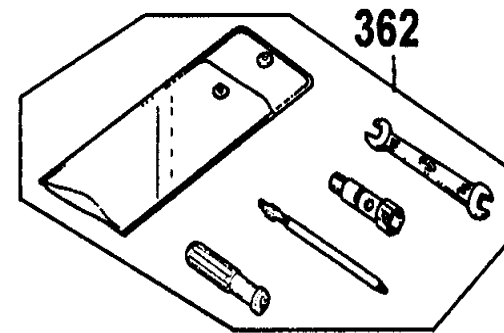
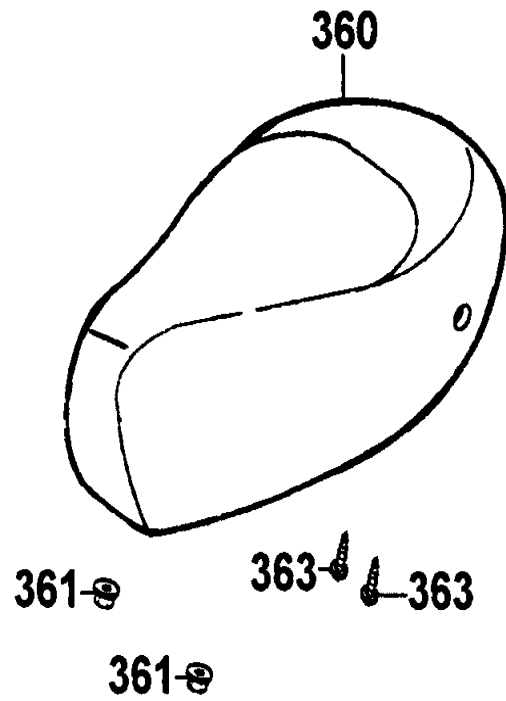

F 9

販賣記號	項目	零件號碼	版數	英文名稱	中文名稱	需要用量	參考價
Sales mark	Ref no	Part no	Ver	Description	Chinese	Regd no	Ref Price
**	360	77200-KFA6-9000	0	SEAT COMP	座墊	1	
*	361	94050-06080	0	NUT FLANGE 6MM	特殊螺帽	2	
*	362	89010-KBN-9000	0	TOOL SET	手工具組	1	
*	363	93903-34380	0	SCREW TAPPING 4*12	螺釘	2	

F 10 Fuel Tank

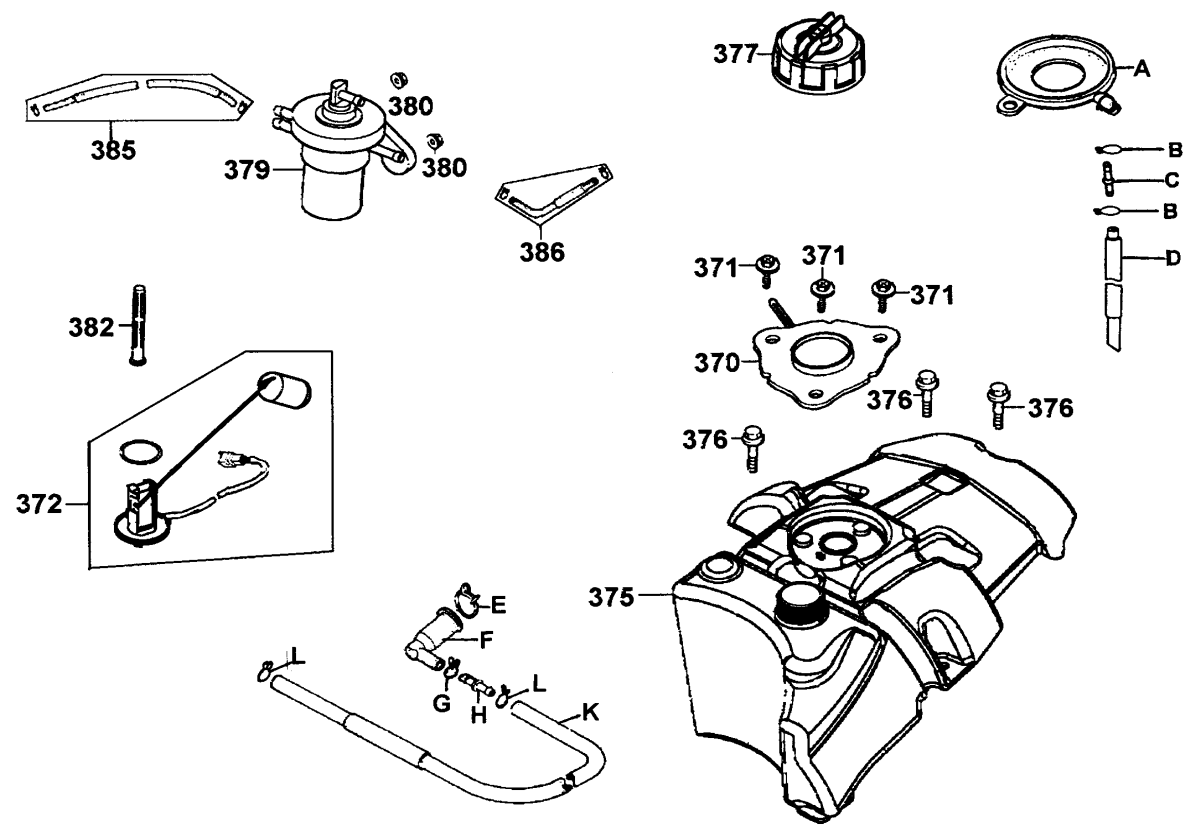

販賣記號	項目	零件號碼	版數	英文名稱	中文名稱	需要用量	參考價
Sales mark	Ref no	Part no	Ver	Description	Chinese	Regd no	Ref Price
*	370	37802-KEC8-9000	0	RET FUEL UNIT	浮筒計承件	1	
*	371	90302-GY6-9010	0	BOLT WASH 5*12	螺絲	3	
*	372	3780A-KFA6-9000	0	FUEL UNIT ASSY	燃料量指示器組	1	
*	375	17510-KFA6-8000	3	TANK COMP FUEL	油箱	1	
*	376	90111-187-0000	1	NUT FLANGE 6MM	螺帽	3	
*	377	1762A-KFA6-9000	2	CAP ASSY FUEL FILLER	油箱蓋	1	
*	379	16950-KEC8-9000	1	AUTO COCK ASSY FUEL	自動油杯組	1	
*	380	94050-06080	0	NUT FLANGE 6MM	螺帽	2	
*	382	16952-KEC8-9000	0	SCREEN FUEL STRAINER	濾油網	1	
*	385	9500B-KFA6-9000	0	TUBE ASSY VACUUM	真空管組	1	
*	386	9500C-KFA6-9000	0	TUBE ASSY FUEL	油管組	1	
*	A	17550-KFA6-9000	0	TRAY FUEL CAP	油箱蓋托盤	1	
*	B	95002-02080	0	CLIP B8 TUBE	管夾	2	
*	C	17685-KCZ-9000	0	JOINT TUBE	油管接頭	1	
*	D	17530-KFA6-9000	0	TUBE ASSY FUEL DRAIN	油管	1	
*	E	15772-551-0000	1	CLIP BRTHR TUBE	管夾	1	
*	F	16960-KEC8-9000	0	TUBE FUEL STRN	濾油管接頭	1	
*	G	95002-5000	0	CLIP C9 TUBE	管夾	1	
*	H	55102-166-0010	0	JOINT OIL TUBE	油管接頭	1	
*	K	16955-KFA6-9000	0	TUBE ASSY FUEL	油管組	1	

F 10 Fuel Tank

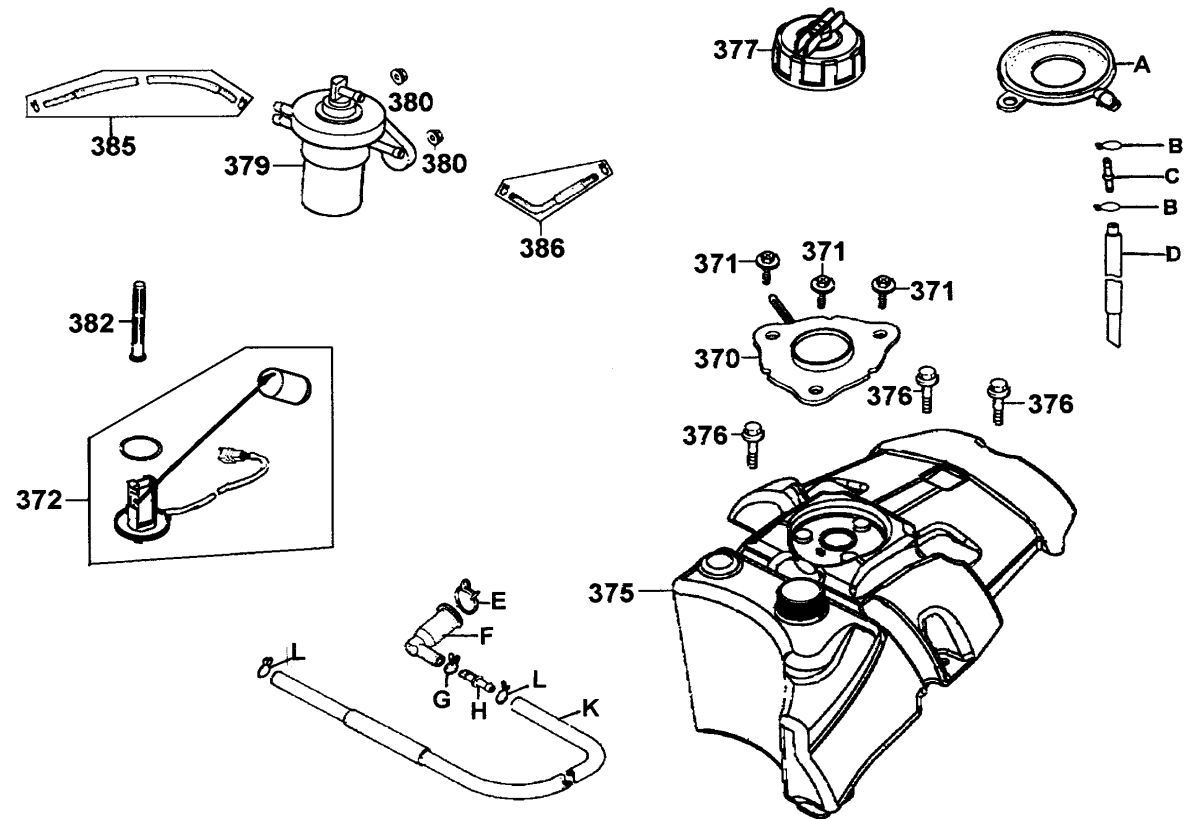

F 10

販賣記號	項目	零件號碼	版數	英文名稱	中文名稱	需要用量	參考價
Sales mark	Ref no	Part no	Ver	Description	Chinese	Regd no	Ref Price
*	L	95002-02100	0	CLIP B10 TUBE	管夾	2	

F 11 Battery

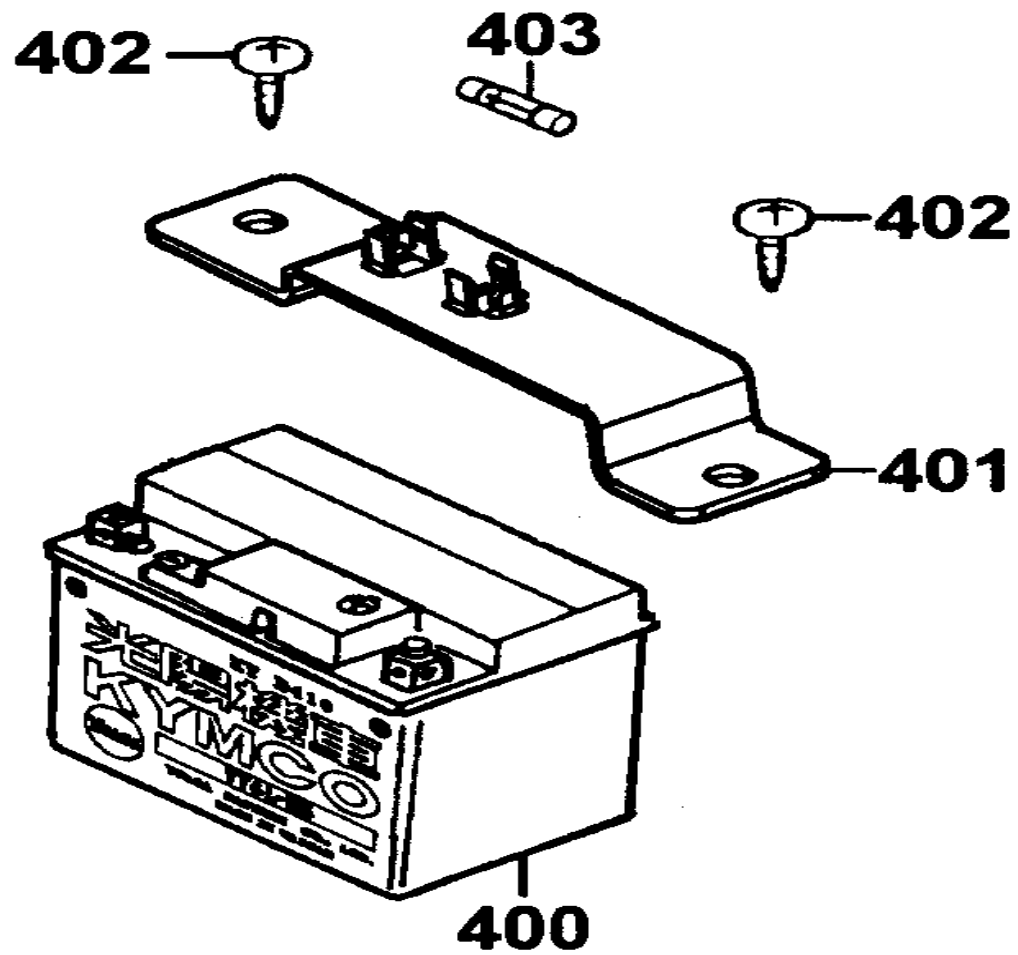

F 11

販賣記號	項目	零件號碼	版數	英文名稱	中文名稱	需要用量	參考價
Sales mark	Ref no	Part no	Ver	Description	Chinese	Regd no	Ref Price
*	400	31500-KBN-9210-M1	2	BATTERY YTX5L-BS	電瓶	1	
*	401	50328-KFA6-9000	0	BAND BATTERY	電瓶束帶	1	
*	402	93903-35380	0	SCREW TAPPING 5*16	螺絲	2	
*	403	98200-10700	0	FUSE A7	保險絲	1	

F 12 Oil Tank

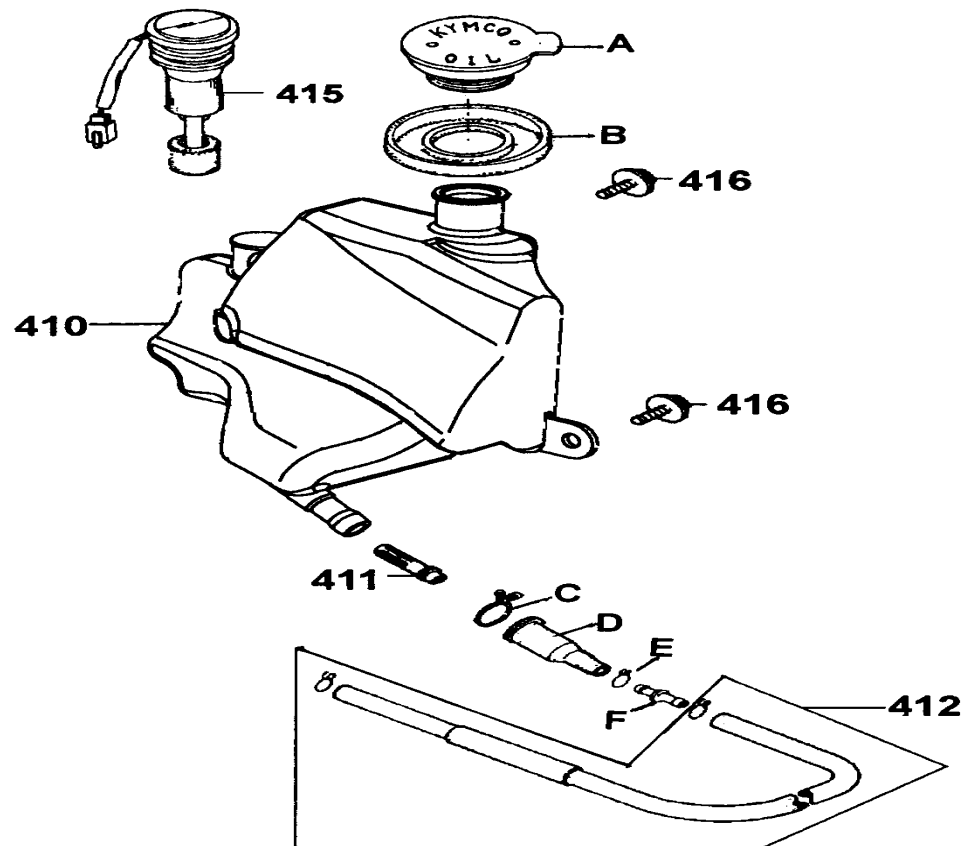

販賣記號	項目	零件號碼	版數	英文名稱	中文名稱	需要用量	參考價
Sales mark	Ref no	Part no	Ver	Description	Chinese	Regd no	Ref Price
*	410	55100-KFA6-9000	0	TANK OIL	機油箱	1	
*	411	17502-187-0000	0	OIL STRAINER	濾油器	1	
*	412	55200-KBN-9010	0	TUBE ASSY OIL	噴合油管組	1	
*	415	35410-KEB7-9000	0	SW COMP OIL LEVEL	機油量指示器	1	
*	416	90302-GY6-9010	0	BOLT-WASH 5*12	螺絲	2	
*	A	55106-KEB7-9000	2	CAP TANK OIL	機油箱蓋	1	
*	B	55121-KEB7-9000	0	RUBBER OIL GUIDE	油箱托蓋	1	
*	C	15772-551-0000	1	CLIP BREATHER TUBE	通氣管夾	1	
*	D	55201-GC8-0010	0	JOINT OIL STRN	濾油管接頭	1	
*	E	95002-50000	0	CLIP C9 TUBE	燃油軟管夾	1	
*	F	55102-166-0000	1	JOINT OIL TUBE	油管接頭	1	

F 13 Body Cover●Luggage Box

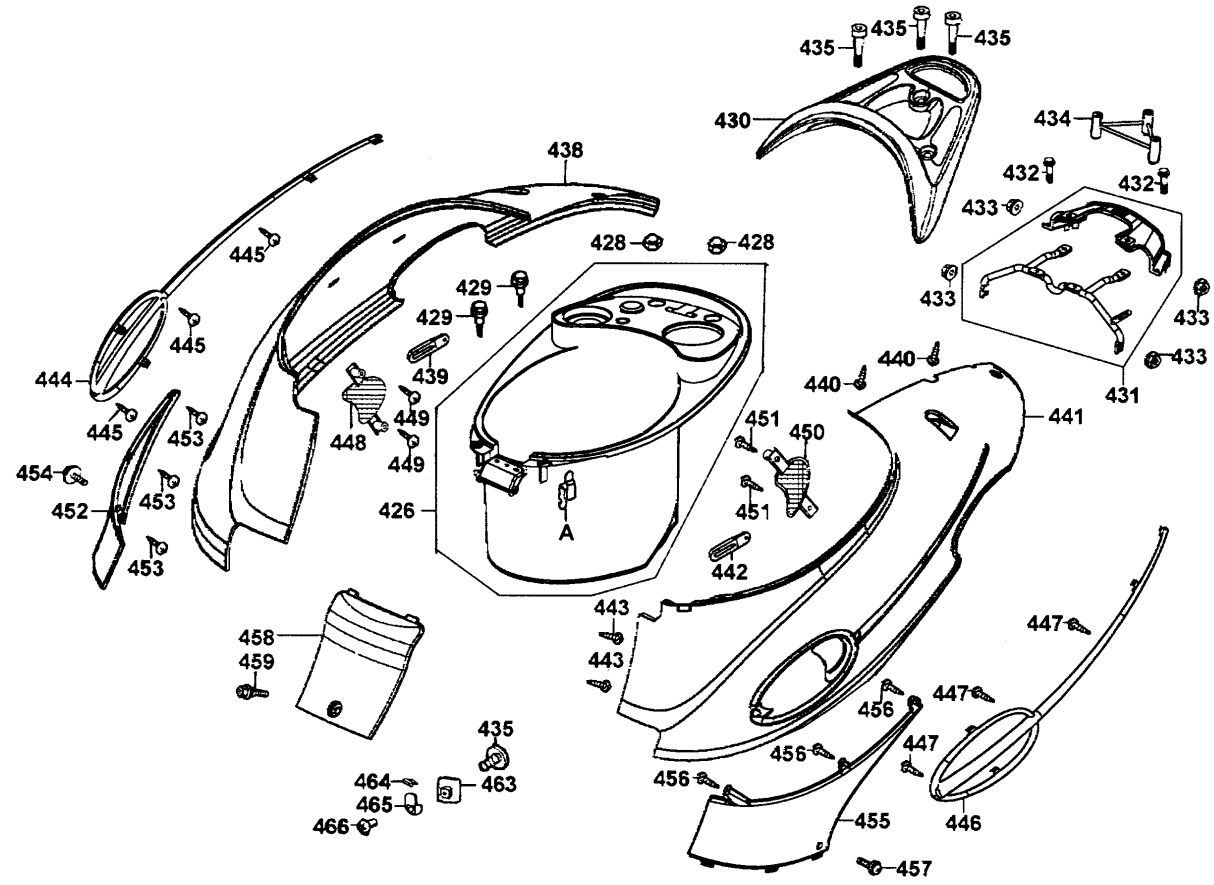

販賣記號	項目	零件號碼	版數	英文名稱	中文名稱	需要用量	參考價
Sales mark	Ref no	Part no	Ver	Description	Chinese	Regd no	Ref Price
**	426	81260-KFA6-9000	0	BOX ASSY LUGGAGE	行李箱	1	
*	428	90215-GM0-9100	0	NUT CAP 6MM	圓螺帽	2	
*	429	90111-KW6-0010	0	BOLT FLANGE 6MM	螺絲	2	
**	430	81200-KFA6-9000	0	CARRIER REAR	後架	1	
*	431	81201-KFA6-9000	1	BRKT COMP RR CARRIER	後架支座	1	
*	432	95701-06016-08	0	SCREW SPECIAL 6*16	螺絲	2	
*	433	94050-06080	0	NUT FLANGE 6MM	螺帽 6MM	4	
*	434	81205-KFA6-8000	1	COLLAR COMP RR CARRIER	後架座套筒	1	
*	435	90106-KFA6-9000	0	BOLT SPECIAL 8*75	螺絲	3	
**	438	83500-KFA6-3150-IT	0	COVER SET R BODY	車體右邊蓋	1	
*	439	94591-27000	0	CLIP 2*70	管夾	1	
*	440	93903-34380	0	SCREW TAPPING 4*12	螺絲	2	
**	441	83600-KFA6-3150-IT	0	COVER SET L BODY	車體左邊蓋	1	
*	442	94591-27000	0	CLIP 2*70	管夾	1	
*	443	93903-34380	0	SCREW TAPPING 4*12	螺絲	2	
*	444	83501-KFA6-9000	0	EDGING R BODY COVER	右蓋飾條	1	
*	445	93903-34380	0	SCREW TAPPING 4*12	螺絲	3	
*	446	83601-KFA6-9000	0	EDGING L BODY COVER	左蓋飾條	1	
*	447	93903-34380	0	SCREW TAPPING 4*12	螺絲	3	
*	448	83502-KFA6-9000	0	GRILL R BODY COVER	通氣孔	1	

F 13 Body Cover●Luggage Box

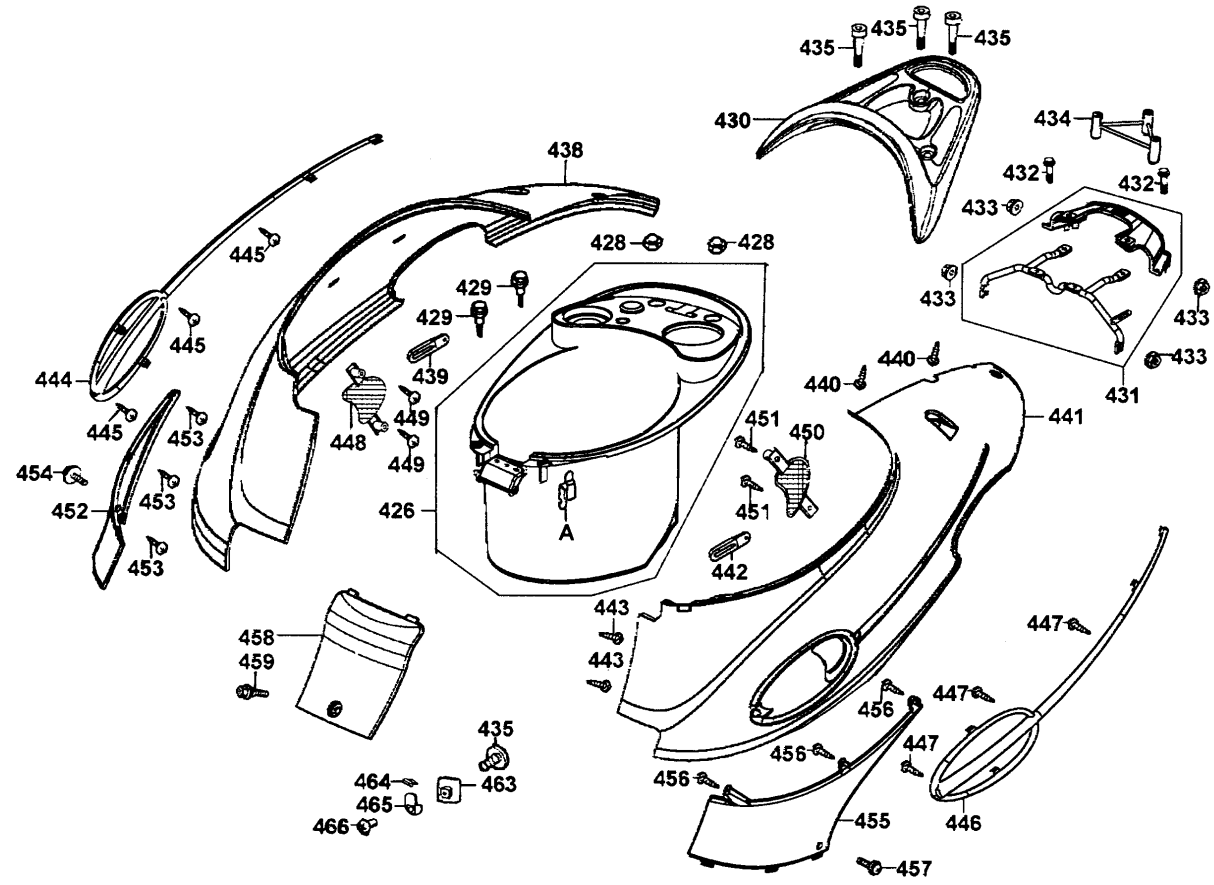

販賣記號	項目	零件號碼	版數	英文名稱	中文名稱	需要用量	參考價
Sales mark	Ref no	Part no	Ver	Description	Chinese	Regd no	Ref Price
*	449	93903-34380	0	SCREW TAPPING 4*12	螺絲	2	
*	450	83602-KFA6-9000	0	GRILL L BODY COVER	通氣孔	1	
*	451	93903-34380	0	SCREW TAPPING 4*12	螺絲	2	
**	452	80151-KFA6-9000	0	COVER R CENTER	右中心蓋	1	
*	453	93903-34380	0	SCREW TAPPING 4*12	螺絲	3	
*	454	93903-34480	0	SCREW TAPPING 4*16	螺絲	2	
**	455	80161-KFA6-9000	0	COVER L CENTER	左中心蓋	1	
*	456	93903-34380	0	SCREW TAPPING 4*12	螺絲	3	
*	457	93903-34480	0	SCREW TAPPING 4*16	螺絲	2	
**	458	80153-KFA6-9000	0	COVER PLUG MAINT	化油器護蓋	1	
*	459	90302-KED5-9000	0	BOLT PAN 5*9	螺絲	1	
*	463	81135-KBG-9000	0	STAY LUGGAGE HOOK	掛鉤座	1	
*	464	81133-KBG-9000	0	STOPPER LUGGAGE	內箱襯蓋	1	
*	465	81134-KFA6-9000	0	HOOK LUGGAGE	掛鉤	1	
*	466	90164-KBG-9000	0	SCREW SPECIAL 6MM	特殊螺絲	1	
*	A	77106-KEB7-9000	0	HOOK HELMENT	安全帽掛	1	

F 14 Air Cleaner

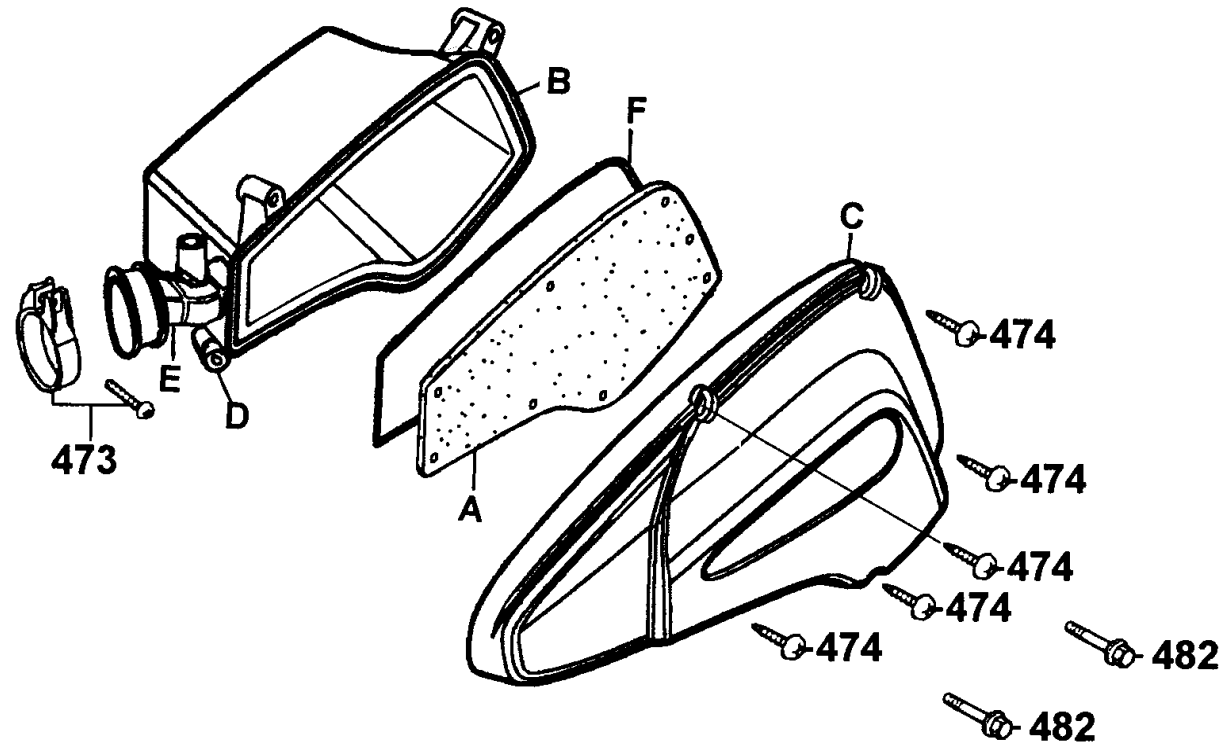

販賣記號	項目	零件號碼	版數	英文名稱	中文名稱	需要用量	參考價
Sales mark	Ref no	Part no	Ver	Description	Chinese	Regd no	Ref Price
*	473	90652-KCT-9000	0	BAND AIR/C CONN	管束帶	1	
*	474	93903-25480	0	SCREW TAPPING 5*20	螺釘	5	
*	482	90114-GM4-0110	1	BOLT FLANGE SH 6*28	螺絲	2	
*	A	17205-KFA6-9000	0	ELEMENT AIR/C	空氣濾清器海綿	1	
*	B	17206-KFA6-9000	0	CASE AIR/C	空氣濾清器箱	1	
*	C	17210-KFA6-9000	0	COVER COMP AIR/C	空氣濾清器蓋	1	
*	D	17208-GR1-0110	0	COLLAR AIR/C SET	套筒	2	
*	E	17253-KFA6-E000-IT	0	TUBE AIR/C CONN	空氣濾清器連接管	1	
*	F	17212-KFA6-9000	0	SEAL AIR/C COVER	空氣濾清箱蓋防塵封	1	

F 15 Exhaust Muffler

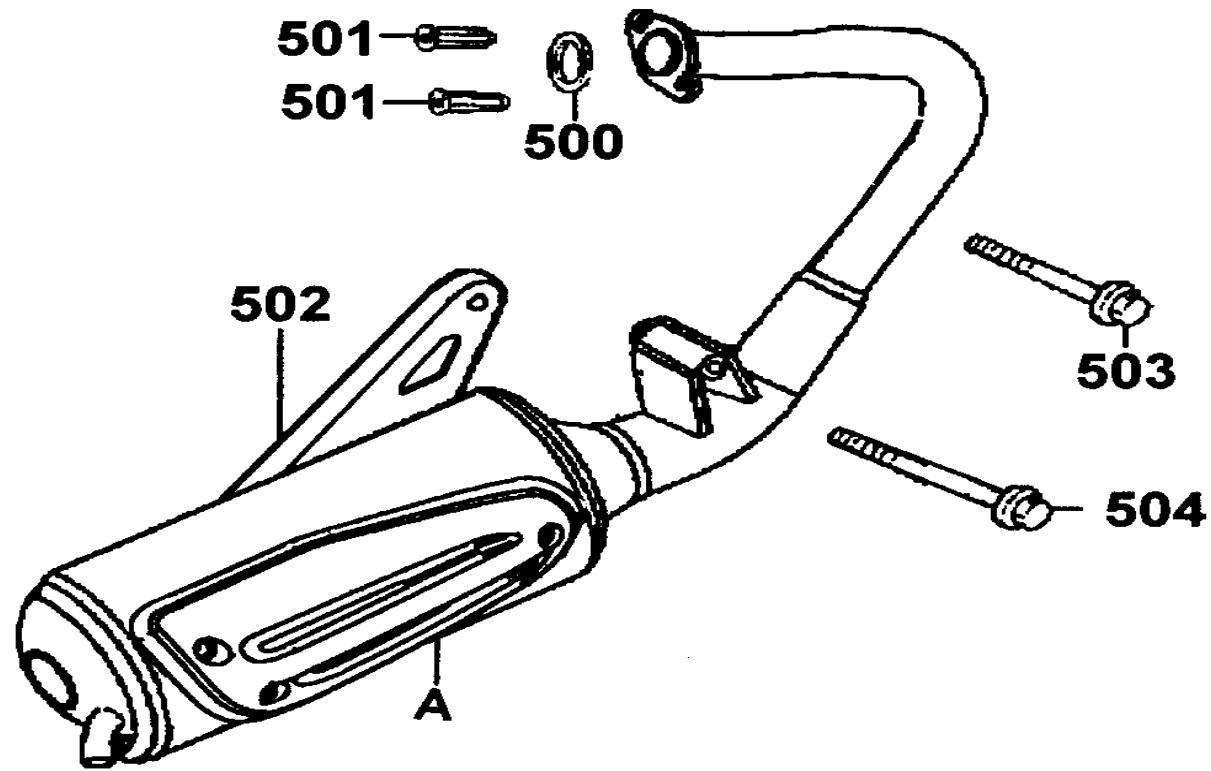

販賣記號	項目	零件號碼	版數	英文名稱	中文名稱	需要用量	參考價
Sales mark	Ref no	Part no	Ver	Description	Chinese	Regd no	Ref Price
*	500	18291-166-0040	0	GASKET EXH PIPE	排氣管墊圈	1	
*	501	90301-KGBG-9000	0	NUT (HEX) CAP 6MM	圓螺帽	2	
*	502	1830A-KFA6-E000-GM	2	MUFFLER ASSY EXH	排氣管組	1	
*	503	95701-08050-07	0	BOLT FLANGE 8*50	螺絲	1	
*	504	95701-08035-08	0	BOLT FLANGE 8*35	螺絲	1	
*	A	18318-KFA3-E000	0	PROTECTOR MUFFLER	排氣管護蓋	1	

F 16 Main Stand●Kick Starter Arm

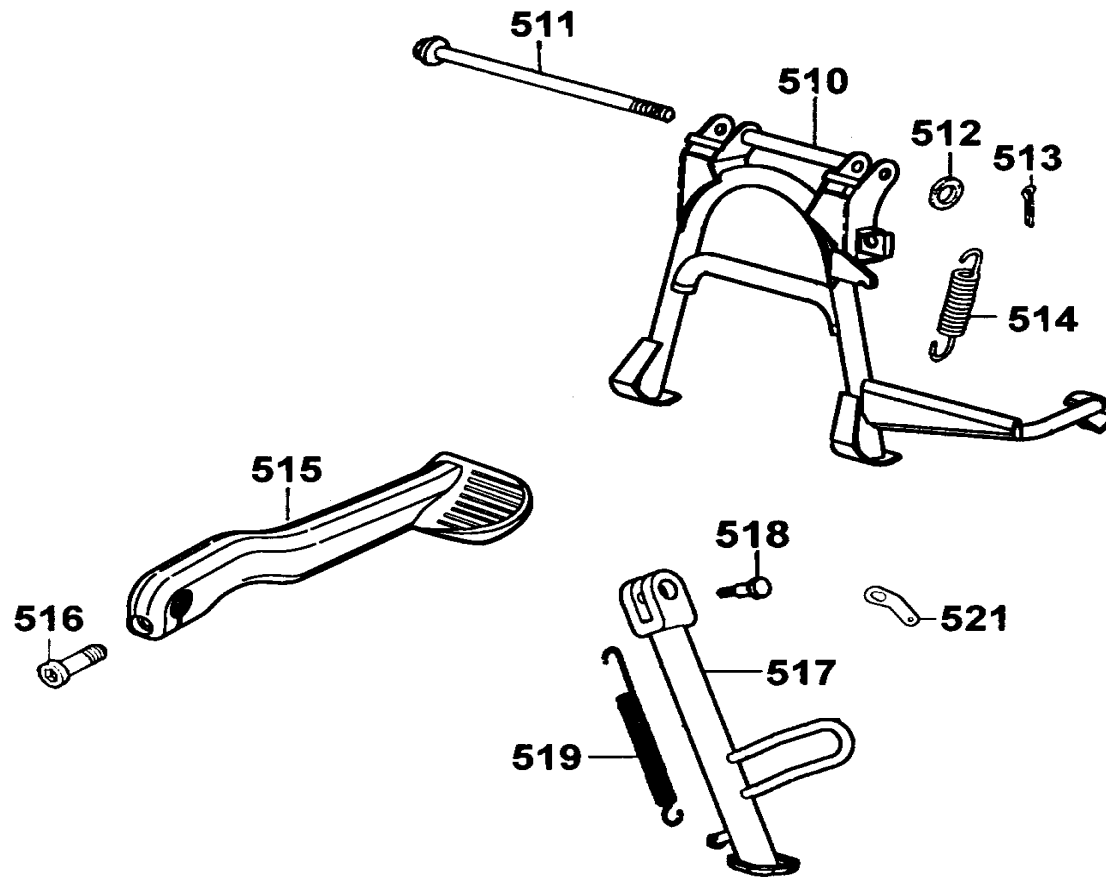

F 16

販賣記號	項目	零件號碼	版數	英文名稱	中文名稱	需要用量	參考價
Sales mark	Ref no	Part no	Ver	Description	Chinese	Regd no	Ref Price
*	510	5050A-KFA6-9000	1	STAND ASSY MAIN	主腳架	1	
*	511	50503-KEB7-9000	1	SHAFT MAIN STAND	主腳架軸	1	
*	512	94101-08700	0	WASHER PLAIN 8MM	華絲	1	
*	513	94251-08400	0	PIN LOCK 8MM	插銷	1	
*	514	50550-KEB7-E000	1	SPG ASSY MAIN STAND	主腳架彈簧	1	
*	515	28300-KFA6-9000	1	ARM ASSY KICK STARTER	起動踏桿組	1	
*	516	96700-KFA6-9000	0	SOCKET BOLT 6*20	螺絲	1	
*	517	50530-KFA6-E000	0	BAR SIDE STAND	側腳架	1	
*	518	90108-KFA6-E000	0	SCREW SIDE STAND PIVOT	側腳架螺絲	1	
*	519	50535-KEB7-E000	0	SPRING COMP SIDE STAND	側腳架彈簧	1	
*	521	50531-KEB7-E000	0	PLATE SPRING STOPPER	彈簧制止板	1	

F 17 Rear Cushion

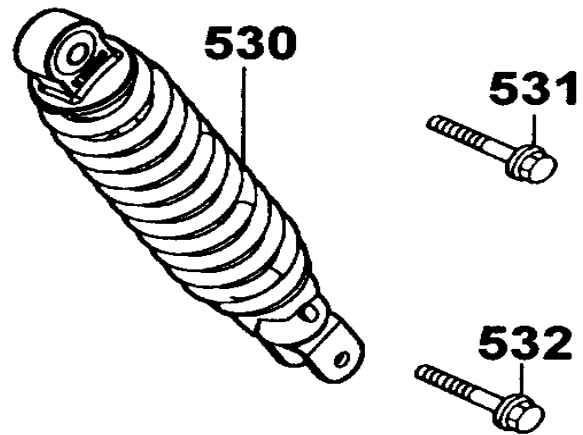

F 17

販賣記號	項目	零件號碼	版數	英文名稱	中文名稱	需要用量	參考價
Sales mark	Ref no	Part no	Ver	Description	Chinese	Regd no	Ref Price
*	530	52400-KFA6-E000	1	CUSHION ASSY RR	後避震器	1	
*	531	95801-10035-08	0	BOLT FLANGE 10*35	螺絲	1	
*	532	95801-08035-08	0	BOLT FLANGE 8*35	螺絲	1	

F 18 Front Winker ● Rear Winker

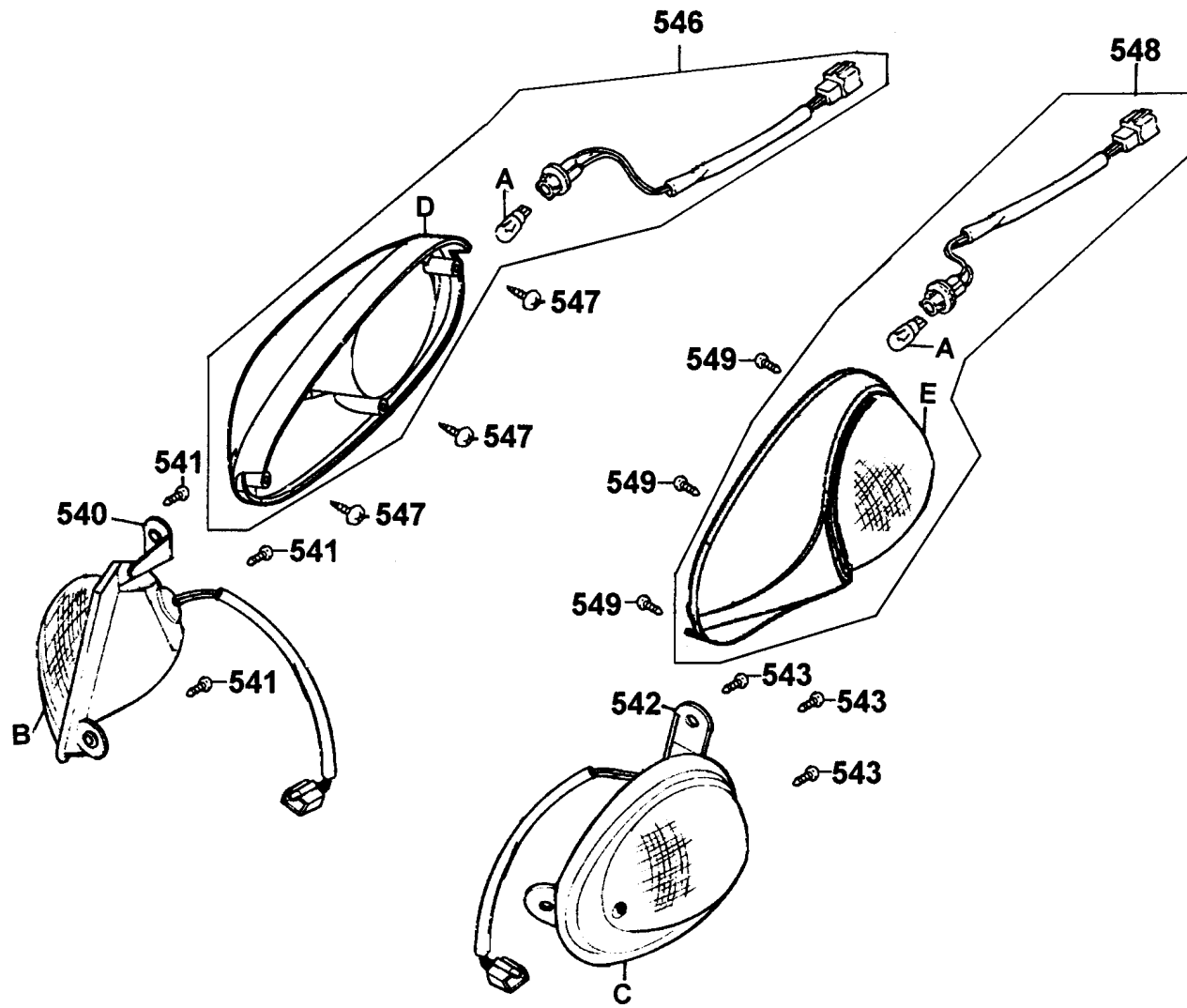

販賣記號	項目	零件號碼	版數	英文名稱	中文名稱	需要用量	參考價
Sales mark	Ref no	Part no	Ver	Description	Chinese	Regd no	Ref Price
*	540	33400-KFA6-E000	1	WINKER ASSY R FR	右前方向燈組	1	
*	541	93903-34380	0	SCREW TAPPING 4*12	螺絲	3	
*	542	33450-KFA6-E000	1	WINKER ASSY L FR	左前方向燈組	1	
*	543	93903-34380	0	SCREW TAPPING 4*12	螺絲	3	
*	546	33600-KFA6-E000	1	WINKER ASSY R RR	右後方向燈組	1	
*	547	93903-34380	0	SCREW TAPPING 4*12	螺絲	3	
*	548	33650-KFA6-E000	1	WINKER ASSY L RR	左後方向燈組	1	
*	549	93903-34380	0	SCREW TAPPING 4*12	螺絲	3	
*	A	34905-KCP-9000	0	BULB WINKER	方向燈燈泡	4	
*	B	33402-KFA6-9000	0	LENS R FR WINKER	右前方向燈殼	1	
*	C	33452-KFA6-9000	0	LENS L FR WINKER	左前方向燈殼	1	
*	D	33602-KFA6-E000	0	LENS R FR WINKER	右後方向燈殼	1	
*	E	33652-KFA6-E000	0	LENS L FR WINKER	左後方向燈殼	1	

F 19 Tail Light

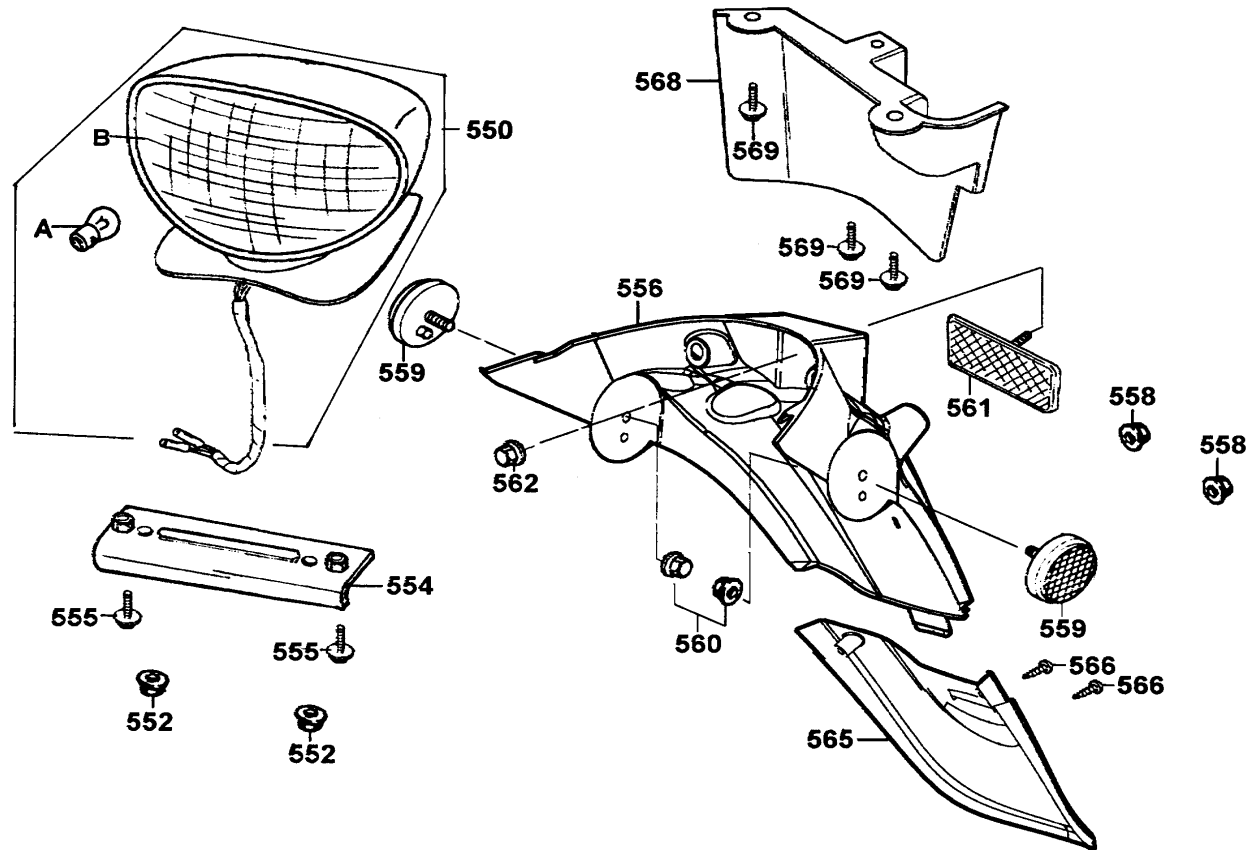

販賣記號	項目	零件號碼	版數	英文名稱	中文名稱	需要用量	參考價
Sales mark	Ref no	Part no	Ver	Description	Chinese	Regd no	Ref Price
*	550	33700-KFA6-E000	1	LIGHT ASSY TAIL	後燈組	1	
*	552	94050-05080	0	NUT FLANGE 5MM	螺帽	3	
*	554	50190-KFA6-9000	0	STAY LIGHT TAIL	後燈座	1	
*	555	90302-GY6-9010	0	BOLT-WASH 5*12	螺絲	2	
**	556	80105-KFA6-9000	0	FENDER REAR	後土除	1	
*	558	90301-634-6700	0	NUT FLANGE 6MM	螺帽	2	
*	559	33741-GY6-C300	1	REFLEX REFLECTOR	反射片	2	
*	560	94050-06080	0	NUT FLANGE 6MM	螺帽	2	
*	561	33741-KFA6-9000	0	REFLEX REFLECTOR	反光鏡片	1	
*	562	94050-05080	0	NUT FLANGE 5MM	螺帽	1	
**	565	80106-KFA6-9000	0	FENDER LOW REAR	後下土除	1	
*	566	93903-34380	0	SCREW TAPPING 4*12	螺絲	2	
*	568	80101-KFA6-9000	0	FENDER A ASSY RR	後土除	1	
*	569	90302-GY6-9010	0	BOLT WASH 5*12	螺絲	3	
*	A	34906-KCP-9000	0	BULB TAIL & STOP	後燈燈泡	1	
*	B	33704-KFA6-9000	0	LENS COMP TAIL LIGHT	後燈殼	1	

F 20 Wire Harness

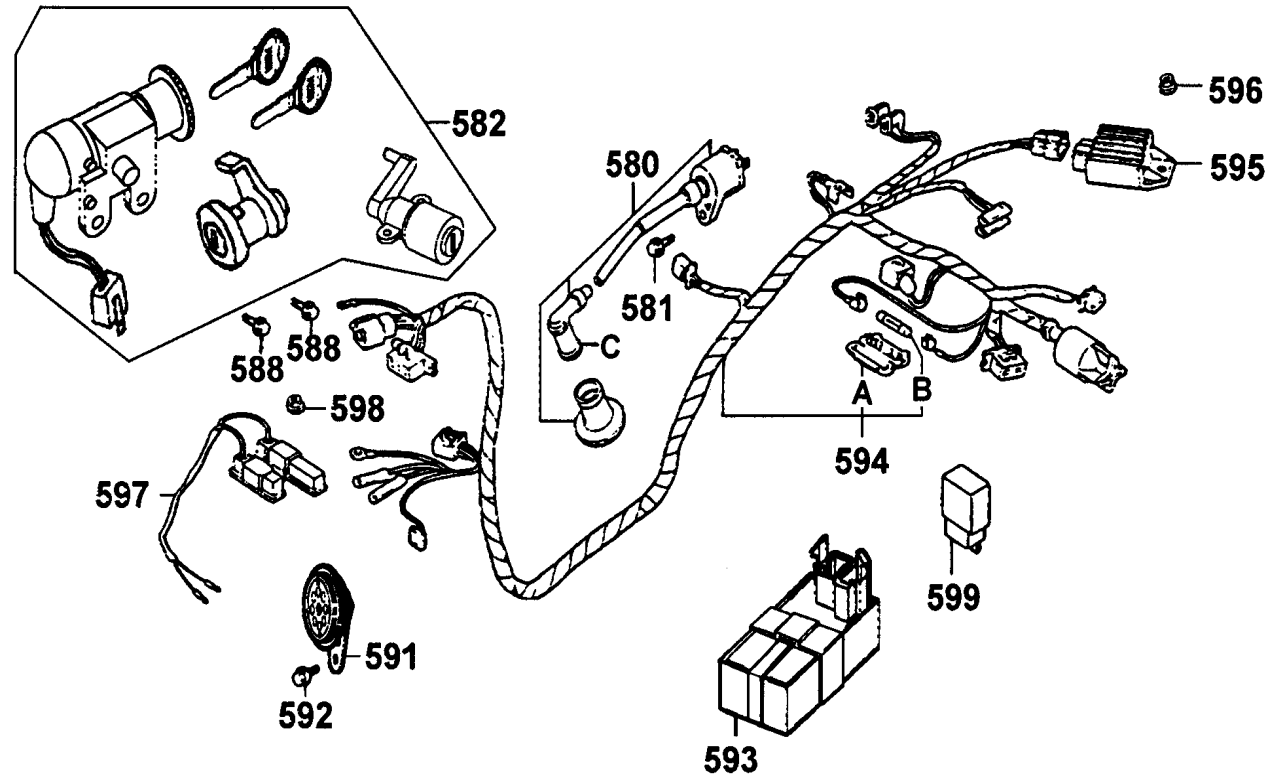

販賣記號	項目	零件號碼	版數	英文名稱	中文名稱	需要用量	參考價
Sales mark	Ref no	Part no	Ver	Description	Chinese	Regd no	Ref Price
*	580	3051A-KFA6-9000-M2	1	COIL ASSY IGN	點火線圈	1	
*	581	90112-KDR-9000	0	BOLT FLANGE 5*22	螺絲	1	
*	582	35010-KFA6-E000-M1	1	KEY SET	開關組	1	
*	582	35010-KFA6-E000-M2	1	KEY SET	開關組	1	
*	588	95701-KEB7-E000	0	BOLT FLANGE 6*16	螺絲	2	
*	591	38110-GS7-E000-M1	1	HORN COMP	喇叭	1	
*	592	95701-06012-08	0	BOLT FLANFE 6*12	螺絲	1	
*	593	30400-KFA6-9000	0	UNIT ASSY CDI	C.D.I組	1	
*	594	32100-KFA6-9000	2	HARNESS WIRE	主配線	1	
*	595	31600-KDU-9000	0	REG REC COMP	整流器	1	
*	596	94050-06080	0	NUT FLANGE 6MM	特殊螺帽	1	
*	597	35400-KBN-9200	0	RESISTOR COMP	電阻器組	1	
*	598	94050-06080	0	NUT FLANGE 6MM	螺帽	1	
*	599	38500-KFA6-9000	0	RELAY COMP START	啓動繼電器	1	
*	A	32120-155-0010	0	CASE FUSE	保險絲盒	1	
*	B	98200-10700	0	FUSE A7	保險絲	1	
*	C	30700-KBN-9010	1	CAP ASSY NOISE SUPPR	火星塞蓋	1	

F 21 Frame Body

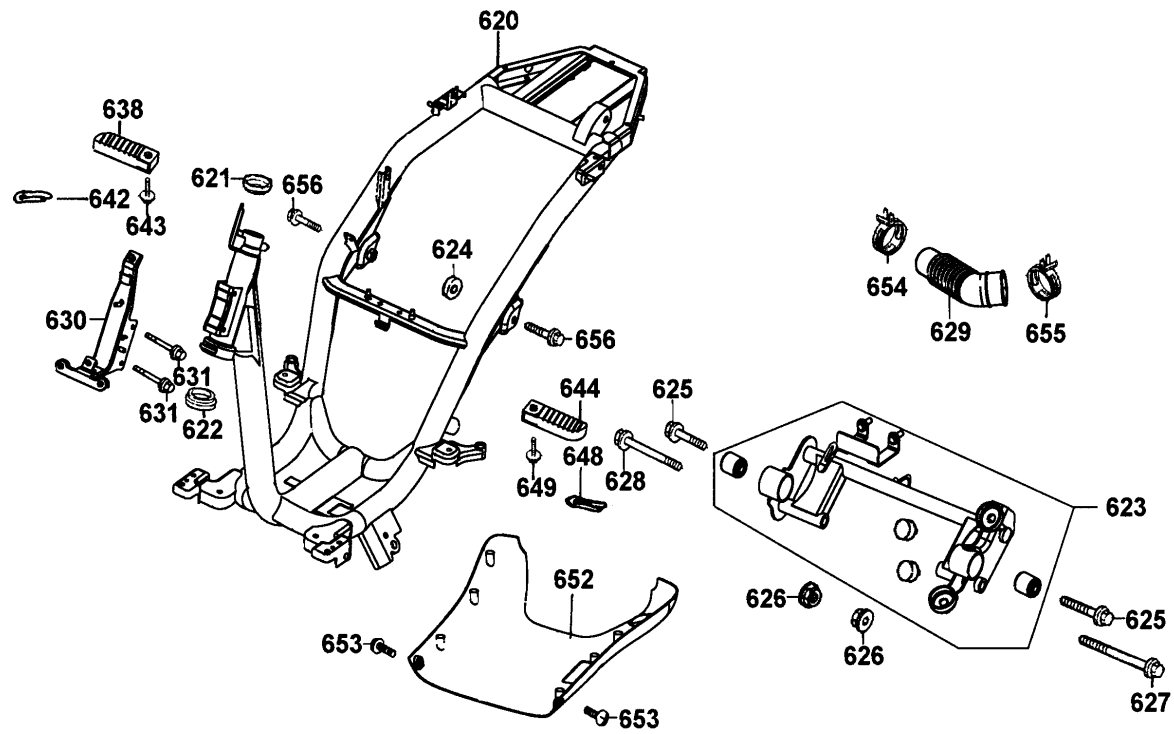

販賣記號	項目	零件號碼	版數	英文名稱	中文名稱	需要用量	參考價
Sales mark	Ref no	Part no	Ver	Description	Chinese	Regd no	Ref Price
*	620	50100-KFA6-9000	2	BODY COMP FRAME	車體	1	
*	621	50301-KN7-6710	2	RACE UPPER STRG BALL	上珠碗	1	
*	622	50302-268-0110	0	RACE UNDER STRG BALL	下珠碗	1	
*	623	50350-KFA6-9000	0	HANGER ASSY ENG	引擎吊架組	1	
*	624	90121-GY6-9010	0	COLLAR DISTANCE	套筒	1	
*	625	90106-GY6-9010	0	BOLT FLANGE 10*55	螺絲	2	
*	626	90304-GE8-0030	1	NUT U 10MM	螺帽	2	
*	627	95801-10100-07	0	BOLT FLANGE 10*100	螺絲	1	
*	628	95801-10115-07	0	BOLT FLANGE 10*115	螺絲	1	
*	629	19410-KFA6-9000	0	HOSE COOLING	冷卻管	1	
*	630	64315-KFA6-9000	0	STAY FR COVER	前護蓋支柱	1	
*	631	95701-06045-08	0	BOLT FLANGE 6*45	螺絲	2	
*	638	50700-KFA6-9000	2	BAR R REAR STEP	右後踏桿	1	
*	642	94103-06000	0	WASHER PLAIN PIN 6MM	銷		
*	643	95701-06012-08	0	BOLT FLANGE 6*12	螺絲	1	
*	644	50710-KFA6-9000	2	BAR L REAR STEP	左後踏桿	1	
*	648	94103-06000	0	WASHER PLAIN PIN 6MM	銷	1	
*	649	95701-06012-08	0	BOLT FLANGE 6*12	螺絲	1	
**	652	64400-KFA6-9000	0	COWL UNDER	前擋泥板	1	
*	653	90110-GW0-0010	0	SCREW SPECIAL 6*14	螺絲	2	

F 21 Frame Body

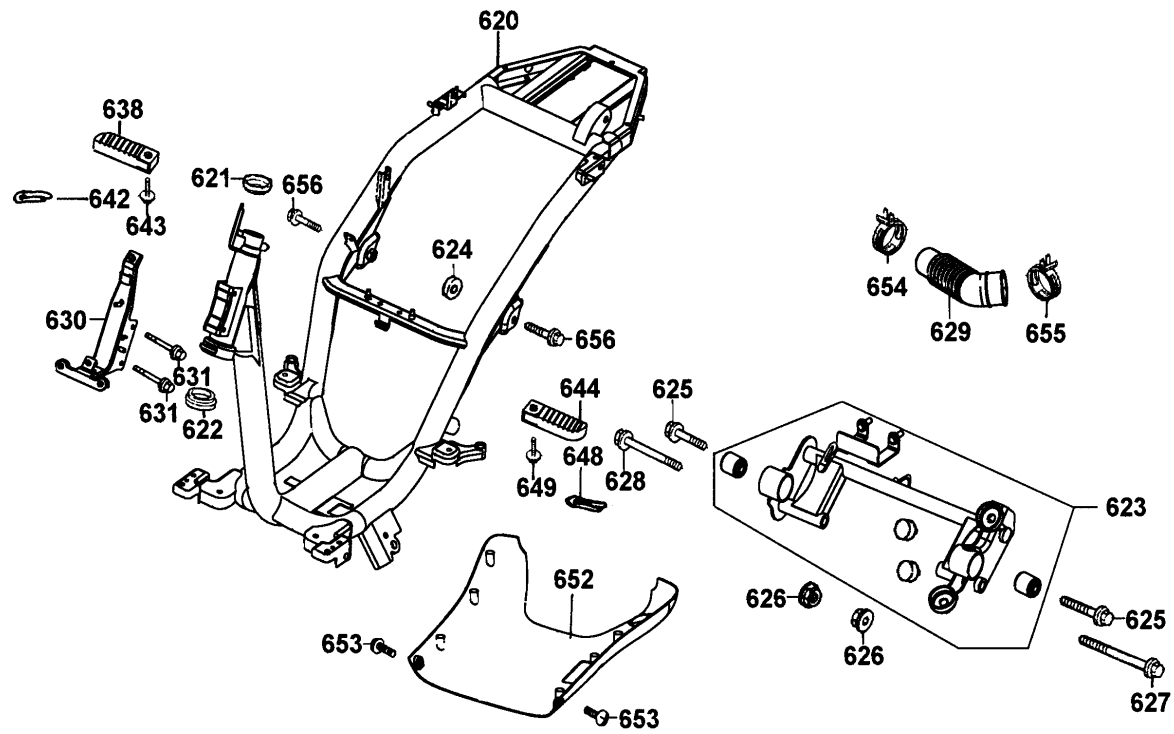

販賣記號	項目	零件號碼	版數	英文名稱	中文名稱	需要用量	參考價
Sales mark	Ref no	Part no	Ver	Description	Chinese	Regd no	Ref Price
*	654	19411-KBN-9000	1	CLIP HOSE	管夾	1	
*	655	17215-KBN-2000	0	CLIP ASSY AIR/C DUCT	管夾	1	
*	A	50352-KFA6-9000	0	STOPPER RUBBER	制止橡皮	2	
*	B	50353-GG2-7110	1	BUSH SWING LOCK	襯套	2	

F 22 Separated Parts Of Fr Fork

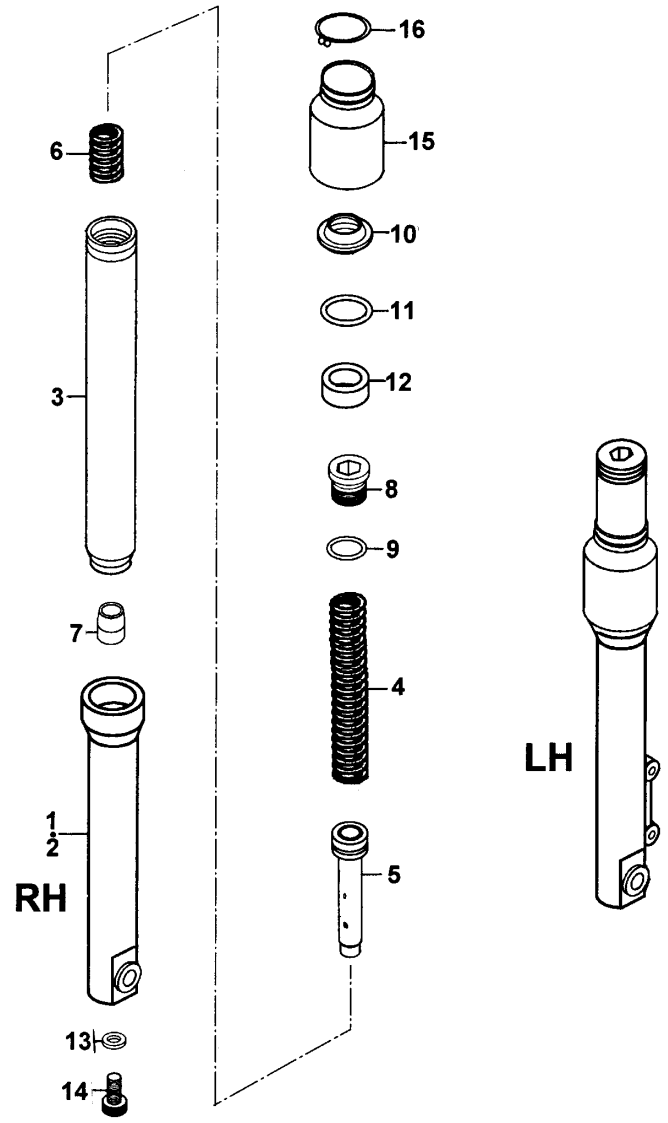

販賣記號	項目	零件號碼	版數	英文名稱	中文名稱	需要用量	參考價
Sales mark	Ref no	Part no	Ver	Description	Chinese	Regd no	Ref Price
*	1	51420-KFA6-9000	0	BOTTOM CASE R	右前避震器底管	1	
*	2	51520-KFA6-9000	0	BOTTOM CASE L	左前避震器底管	1	
*	3	51410-KFA6-9000	0	FORK PIPE COMP	前避震器管	2	
*	4	51401-KFA6-E000	0	SPRING	彈簧	2	
*	5	51429-KFA6-9000	0	PIPE SEAT COMP	避震管座	2	
*	6	51412-KFA6-E000	0	REBOUND SPRING	回位彈簧	2	
*	7	51432-KFA6-9100	0	OIL LOCK PIECE	止油接頭	2	
*	8	94605-KBE-9000	1	FORK BOLT	螺絲	2	
*	9	94608-30000	0	O-RING	O環	2	
*	10	91254-KC5-0030	0	DUST SEAL	防塵封	2	
*	11	90601-354-0010	0	OIL SEAL STOPPER RING	油封止位環	2	
*	12	91255-446-0140	0	OIL SEAL	油封	2	
	13	90554-KHB4-0010	0	PACKING	特殊華司	2	
	14	90116-KHB4-7220	0	SOCKET BOLT	內六角螺絲	2	
	15	51430-KFA6-9000	0	BOOT FR FORK	護套	2	
	16		0	BOOT BAND	護套夾	2	

F 23 Caution Label

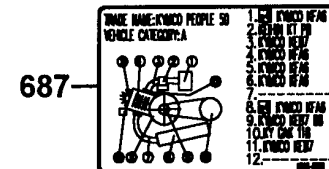
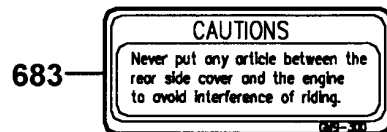
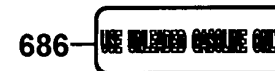
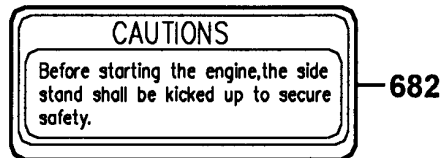
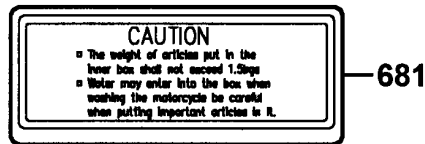
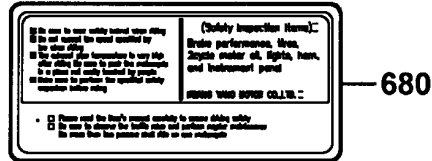

販賣記號	項目	零件號碼	版數	英文名稱	中文名稱	需要用量	參考價
Sales mark	Ref no	Part no	Ver	Description	Chinese	Regd no	Ref Price
	680	87560-KBN-E000	1	MARK DRIVE CAUTION	標籤	1	
	681	81218-KAC-P000	0	CAUTION INNER BOX	標籤	1	
	682	87541-GR1-E000	0	CAUTION SIDE STAND	警告標籤	1	
	683	87542-GR1-E000	1	MARK MAINT CAUTION	警告標籤	1	
	684	87505-KFA6-E000	0	LABEL TIRE	標籤	1	
	685	87541-KEB7-E000-GM	1	CAUTION AUTO SIDE STAND	標籤	1	
	686	87501-KDR-E000	0	CAUTION USE GAS ONLY	標籤	1	
	687	87224-KFA6-E000-IT	0	CAUTION ANTI TAMPERING	標籤	1	

People 690

ECO-CAT 691

694 БАЙОАВ()

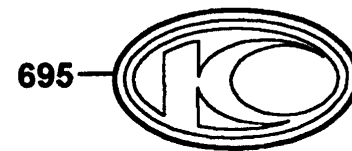
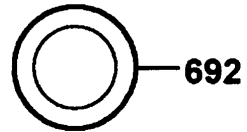

販賣記號	項目	零件號碼	版數	英文名稱	中文名稱	需要用量	參考價
Sales mark	Ref no	Part no	Ver	Description	Chinese	Regd no	Ref Price
*	690	86202-KFA6-E000-IT	0	EMB BODY COVER	車體邊蓋貼紙	2	
*	691	86212-KFA6-E000-IT	0	EMB B BODY COVER	邊蓋貼紙 B	2	
*	692	86030-KFA6-E000	0	EMB HANDLE COVER RR	貼紙	4	
*	694	87503-KFA6-E000-FL	0	MARK MODEL	貼紙	1	
*	695	86102-KFA6-E000-IT	0	EMB FR COVER	前護蓋貼紙	1	



零件號碼索引
PARTS NO. INDEX

零 件 號 碼 索 引

PART NO. INDEX

零 件 號 碼 PART NO.	版數 VER.	頁 次 PAGE	零 件 號 碼 PART NO.	版數 VER.	頁 次 PAGE	零 件 號 碼 PART NO.	版數 VER.	頁 次 PAGE
			14100-KEB7-9000	0	P-35	17510-KFA6-8000	3	P-67
11000						17530-KFA6-9000	0	P-67
			15000			17550-KFA6-9000	0	P-67
11100-KEB7-3250	4	P-33				1762A-KFA6-9000	2	P-67
11100-KEB7-9000	4	P-33	15100-GAK-9500	13	P-35	17685-KCZ-9000	0	P-67
11102-187-0030	3	P-33	15110-KEB7-9000	0	P-35	17910-KFA6-9000	0	P-49
11108-KEB7-9000	0	P-19	1552A-KEB8-9000	0	P-35			
11200-KFA6-3050	0	P-33	15772-551-0000	1	P-67	18000		
11203-GC7-3010	2	P-33	15772-551-0000	1	P-73			
11203-KDU-9000	0	P-31				18291-166-0040	0	P-81
11204-KEB7-9000-H1	0	P-33	16000			1830A-KFA6-E000-GM	2	P-81
11205-GAH-0040-H1	0	P-33				18318-KFA3-E000	0	P-81
11205-KED5-9000-H1	0	P-33	1610K-KFA6-E130-IT	1	P-39			
11208-GAK-9010	0	P-35	1621A-GAK-9010	0	P-35	19000		
11341-KFA6-9000	0	P-23	16710-KBN-9000	0	P-39			
11395-KFA6-9000	0	P-23	1671A-KBN-9010	0	P-39	19410-KFA6-9000	0	P-93
			16950-KEC8-9000	1	P-67	19411-KBN-9000	1	P-95
12000			16952-KEC8-9000	0	P-67	19510-GW2-9010	2	P-19
			16955-KFA6-9000	0	P-67	19600-KEB7-9000	0	P-15
12101-KFA6-E100	0	P-17	16960-KEC8-9000	0	P-67	1962A-KEB7-E000	0	P-15
12191-KEB7-9000	0	P-17						
12201-KFA6-E100	0	P-17	17000			21000		
12251-KEB7-9000	0	P-17						
			17100-KEB7-9010	0	P-35	21200-KFA6-3050	0	P-31
13000			17111-KEB7-9000	0	P-35	21395-KFA6-9000	0	P-31
			17112-KEB7-9000	0	P-35			
13000-GAK-9210	5	P-37	17205-KFA6-9000	0	P-79	22000		
13011-GAK-9120-M1	0	P-37	17206-KFA6-9000	0	P-79			
13101-GW-9010	1	P-37	17208-GR1-0110	0	P-79	22100-GR1-7510	0	P-27
13111-166-0010	1	P-37	17210-KFA6-9000	0	P-79	22102-KEB7-9000	0	P-25
13115-156-0010	0	P-37	17212-KFA6-9000	0	P-79	22103-KEB7-9000	0	P-25
			17215-KBN-2000	0	P-95	22105-KEB7-E000	0	P-25
14000			17253-KFA6-E000-IT	0	P-79	22110-KFA1-2200	0	P-25
			17502-187-0000	0	P-73	22121-GW0-9010	0	P-25

零 件 號 碼 索 引

PART NO. INDEX

零 件 號 碼 PART NO.	版數 VER.	頁 次 PAGE	零 件 號 碼 PART NO.	版數 VER.	頁 次 PAGE	零 件 號 碼 PART NO.	版數 VER.	頁 次 PAGE
22131-GAH-7810	0	P-25	30000			33600-KFA6-E000	1	P-87
22132-GW0-0010	1	P-25				33602-KFA6-E000	0	P-87
22300-KCX-9000	0	P-27	30400-KFA6-9000	0	P-91	33650-KFA6-E000	1	P-87
22350-GAK-9300	1	P-27	3051A-KFA6-9000-M2	1	P-91	33652-KFA6-E000	0	P-87
22401-GG2-9000	0	P-27	30700-KBN-9010	1	P-91	33700-KFA6-E000	1	P-89
22530-GAK-9300	1	P-27				33704-KFA6-9000	0	P-89
22804-148-0010	0	P-27	31000			33741-GY6-C300	1	P-89
						33741-KFA6-9000	0	P-89
23000			31110-KEB7-9000-M1	2	P-19			
			31110-KEB7-9000-M2	1	P-19	34000		
2301A-KEB7-9000	1	P-27	31120-KEB7-9000-M1	2	P-19			
23100-KEB7-9000	0	P-29	31120-KEB7-9000-M2	1	P-19	34901-KFA6-9000	0	P-45
23200-GR1-7510	0	P-27	31209-GAK-9010	1	P-21	34903-KCP-9000	0	P-45
23210-GR1-7510	0	P-27	31210-GAK-9000	0	P-21	34905-KCP-9000	0	P-87
23220-GAK-2200	0	P-27	31210-GAK-9010-M1	0	P-21	34906-KCP-9000	0	P-89
23225-GR1-7510	0	P-27	31500-KBN-9210-M1	2	P-71	34908-GA7-7010-M1	1	P-47
23233-GE8-0000	1	P-27	31600-KDU-9000	0	P-91	34908-MB9-8710-M1	0	P-47
23237-GR1-8810	0	P-27						
23238-GY6-9410	0	P-27	32000			35000		
23411-KFA6-9000	0	P-31						
23420-KFA6-9000	0	P-31	32100-KFA6-9000	2	P-91	35010-KFA6-E000-M1	1	P-91
23431-KBN-9010-H1	1	P-31	32101-GY6-9000	1	P-53	35010-KFA6-E000-M2	1	P-91
23432-KFA6-9000	0	P-31	32105-KFA6-9000	0	P-21	3515A-KGBG-E000	2	P-49
			32120-155-0010	0	P-91	3520A-KGBG-E000	2	P-49
28000						35340-KJ9-0100	4	P-49
			33000			35400-KBN-9200	0	P-91
28211-KEB7-9000	0	P-25				35410-KEB7-9000	0	P-73
28223-KBN-9010	0	P-25	33100-KFA6-9000	0	P-45			
28230-GAK-9210	0	P-25	33120-KFA6-9000	0	P-45	37000		
28250-KCC-9000	0	P-25	33130-KFA6-9000	0	P-45			
28253-GN2-6020-M1	0	P-25	33400-KFA6-E000	1	P-87	37200-KFA6-E000-FL-M1	0	P-47
28255-GS6-0010	0	P-25	33402-KFA6-9000	0	P-87	37200-KFA6-E000-FL-M2	0	P-47
28281-GN2-6030-M1	0	P-25	33450-KFA6-E000	1	P-87	37211-KFA6-9000-M1	0	P-47
28300-KFA6-9000	1	P-83	33452-KFA6-9000	0	P-87	37211-KFA6-9000-M2	0	P-47

零 件 號 碼 索 引

PART NO. INDEX

零 件 號 碼 PART NO.	版數 VER.	頁 次 PAGE	零 件 號 碼 PART NO.	版數 VER.	頁 次 PAGE	零 件 號 碼 PART NO.	版數 VER.	頁 次 PAGE
37213-KFA6-9000-M1	0	P-47	44800-KFA6-9000	0	P-61	50710-KFA6-9000	2	P-93
37802-KEC8-9000	0	P-67	44830-KFA6-9000	0	P-47			
3780A-KFA6-9000	0	P-67	44831-KFA6-9000	0	P-47	51000		
38000			45000			51401-KFA6-E000	0	P-97
						5140A-KFA6-E000	0	P-59
38110-GS7-E000-M1	1	P-91	45105-KFA6-3050	0	P-61	51410-KFA6-9000	0	P-97
38300-KCE-9000	1	P-47	45121-KFA6-9000	0	P-61	51412-KFA6-E000	0	P-97
38500-KFA6-9000	0	P-91	45126-KFA6-9000	0	P-53	51420-KFA6-9000	0	P-97
			45200-KFA6-9000	0	P-61	51429-KFA6-9000	0	P-97
42000			45451-471-0000	2	P-59	51430-KFA6-9000	0	P-97
			45513-KFA6-9000	0	P-53	51432-KFA6-9100	0	P-97
42601-KFA6-9000	0	P-63	45517-GY6-9000	4	P-49	5150A-KFA6-E000	0	P-59
42710-KHB4-9000-M1	0	P-63	45530-KFA6-3050	1	P-53	51520-KFA6-9000	0	P-97
42710-KHB4-9000-M2	0	P-63						
43000			50000			52000		
			50100-KFA6-9000	2	P-93	52400-KFA6-E000	1	P-85
43120-KDU-9000	0	P-63	50190-KFA6-9000	0	P-89			
43141-KFA6-9000	0	P-63	50301-KN7-6710	2	P-93	53000		
43151-KM7-9600	1	P-63	50302-268-0110	0	P-93			
43410-KFA6-9000	0	P-63	50306-196-0010	0	P-59	53100-KHB4-9000	0	P-51
43450-KFA6-9000	1	P-49	50328-KFA6-9000	0	P-71	53105-KBN-9100	0	P-51
43452-GAK-9000	0	P-53	50330-KBE-9000	0	P-57	53125-GN5-9010	0	P-51
43472-161-0000	1	P-49	50350-KFA6-9000	0	P-93	53140-KBN-9600	0	P-49
			50352-KFA6-9000	0	P-95	53166-KBN-9100	0	P-49
44000			50353-GG2-7110	1	P-95	53172-KCT-9000	0	P-49
			50503-KEB7-9000	1	P-83	53175-KFA6-9000	0	P-53
44301-KAA-9000	1	P-61	5050A-KFA6-9000	1	P-83	53178-KFA6-9000	0	P-49
44311-046-0010	0	P-61	50530-KFA6-E000	0	P-83	5317B-KFA6-9000	0	P-49
44600-KFA6-3050	0	P-61	50531-KEB7-E000	0	P-83	53200-KFA6-9000	1	P-59
44620-400-0000	1	P-61	50535-KEB7-E000	0	P-83	53204-KFA6-9000	0	P-51
44710-KHB4-9000-M1	0	P-61	50550-KEB7-E000	1	P-83	53205-KFA6-E000	0	P-51
44710-KHB4-9000-M2	0	P-61	50700-KFA6-9000	2	P-93	53206-KFA6-9000	1	P-51

零 件 號 碼 索 引

PART NO. INDEX

零 件 號 碼 PART NO.	版數 VER.	頁 次 PAGE	零 件 號 碼 PART NO.	版數 VER.	頁 次 PAGE	零 件 號 碼 PART NO.	版數 VER.	頁 次 PAGE
53211-GY6-9400	0	P-59				83600-KFA6-3150-IT	0	P-75
53212-250-0110	0	P-59	77106-KEB7-9000	0	P-77	83601-KFA6-9000	0	P-75
53214-250-0010	0	P-59	77200-KFA6-9000	0	P-65	83602-KFA6-9000	0	P-77
53215-250-0010	0	P-59						
			80000			86000		
55000								
			80101-KFA6-9000	0	P-89	86030-KFA6-E000	0	P-101
55100-KFA6-9000	0	P-73	80105-KFA6-9000	0	P-89	86102-KFA6-E000-IT	0	P-101
55102-166-0010	0	P-73	80106-KFA6-9000	0	P-89	86202-KFA6-E000-IT	0	P-101
55102-166-0010	0	P-67	80151-KFA6-9000	0	P-77	86212-KFA6-E000-IT	0	P-101
55106-KEB7-9000	2	P-73	80153-KFA6-9000	0	P-77			
55121-KEB7-9000	0	P-73	80161-KFA6-9000	0	P-77			
55200-KBN-9010	0	P-73				87000		
55201-GC8-0010	0	P-73	81000					
						87224-KFA6-E000-IT	0	P-99
61000			81131-KFA6-9000	0	P-55	87501-KDR-E000	0	P-99
			81132-KFA6-9000	0	P-55	87503-KFA6-E000-FL	0	P-101
61100-KFA6-9000	0	P-59	81133-KBG-9000	0	P-77	87505-KFA6-E000	0	P-99
			81134-KFA6-9000	0	P-77	87541-GR1-E000	0	P-99
64000			81135-KBG-9000	0	P-77	87541-KEB7-E000-GM	1	P-99
			81141-KFA6-9000	0	P-55	87542-GR1-E000	1	P-99
64301-KFA6-9000	1	P-55	81142-KFA6-9000	0	P-55	87560-KBN-E000	1	P-99
64302-KFA6-9000	1	P-55	81146-GN2-0010	0	P-55			
64303-KFA6-9000	0	P-55	81200-KFA6-9000	0	P-75	88000		
64310-KFA6-9000	2	P-55	81201-KFA6-9000	1	P-75			
64315-KFA6-9000	0	P-93	81205-KFA6-8000	1	P-75	88110-KFA6-9000	1	P-49
64320-KFA6-9000	0	P-57	81218-KAC-P000	0	P-99	88120-KFA6-9000	1	P-49
64400-KFA6-9000	0	P-93	81260-KFA6-9000	0	P-75			
						89000		
75000			83000					
						89010-KBN-9000	0	P-65
75581-673-0010	0	P-55	83500-KFA6-3150-IT	0	P-75			
			83501-KFA6-9000	0	P-75	90000		
77000			83502-KFA6-9000	0	P-75			

零 件 號 碼 索 引

PART NO. INDEX

零 件 號 碼 PART NO.	版數 VER.	頁 次 PAGE	零 件 號 碼 PART NO.	版數 VER.	頁 次 PAGE	零 件 號 碼 PART NO.	版數 VER.	頁 次 PAGE
90001-GAK-9010	0	P-17	90302-SA4-0040	1	P-57	91201-KBN-9220-M1	0	P-33
9000A-KDT-9000	0	P-23	90304-GE8-0030	1	P-51	91202-KBN-9220-M1	0	P-33
90101-GR1-0010	0	P-45	90304-GE8-0030	1	P-93	91204-KBN-9020-M1	1	P-33
90105-KR3-0010	1	P-61	90305-KBN-9030-M2	0	P-63	91211-GK8-0130	0	P-29
90106-GN5-9010	0	P-51	90306-GW0-9020-M1	0	P-61	91252-030-0000	0	P-61
90106-GY6-9010	0	P-93	90307-GJ6-0040	0	P-45	91254-KC5-0030	0	P-97
90106-KFA6-9000	0	P-75	90309-KF0-0030	1	P-31	91255-446-0140	0	P-97
90108-KFA6-E000	0	P-83	90320-692-0000	3	P-57	91255-GE0-0060	0	P-31
90110-GW0-0010	0	P-55	90412-329-0010	0	P-25	91258-410-0000-M2	0	P-61
90110-GW0-0010	0	P-93	90426-KBN-9010	0	P-25	91301-053-0010	0	P-31
90111-187-0000	1	P-67	90429-KBN-9010	0	P-31	91301-KA5-7420-Y1	0	P-29
90111-KW6-0010	0	P-75	90442-044-0000	0	P-27	91302-PA9-0040	0	P-29
90112-KDR-9000	0	P-91	90451-GN2-6010	0	P-25	91304-GB0-9110	1	P-35
90114-166-0070	1	P-53	90454-GB2-0000	0	P-27	91309-GAK-9010	0	P-21
90114-GM4-0110	1	P-79	90474-333-0010	0	P-33	91352-KG8-8330-M2	0	P-63
90115-GE0-0010	0	P-49	90501-KBN-9010	0	P-63			
90116-KHB4-7220	0	P-97	90545-300-0010	2	P-53	92000		
90120-GR1-J000	0	P-35	90554-KHB4-0010	0	P-97			
90121-GY6-9010	0	P-93	90601-354-0010	0	P-97	92700-06028-1B	0	P-17
90122-KBE-9000	0	P-61	90652-KCT-9000	0	P-79			
90145-MS9-6120-M1	0	P-53	90656-GY6-9110	0	P-51	93000		
90164-KBG-9000	0	P-77	90741-035-0010	0	P-37			
90202-187-0010	0	P-27				93404-06020-07	0	P-57
90215-GM0-9100	0	P-75	91000			93500-KGBG-9000	0	P-49
90301-634-6700	0	P-55				93600-04012-1G	0	P-53
90301-634-6700	0	P-89	91001-GA7-7020-M1	0	P-27	93891-05030-07	0	P-51
90301-KGBG-9000	0	P-81	91001-GW0-9020-M1	3	P-33	93903-25480	0	P-79
90302-GY6-9010	0	P-55	91004-KBN-9220-M1	0	P-33	93903-34380	0	P-51
90302-GY6-9010	0	P-67	91004-KN2-9020-M1	0	P-33	93903-34380	0	P-55
90302-GY6-9010	0	P-73	91004-KN2-9020-M1	0	P-31	93903-34380	0	P-57
90302-GY6-9010	0	P-89	91006-KBN-9010	1	P-33	93903-34380	0	P-65
90302-GY6-9400	0	P-59	91009-GE0-0040	0	P-31	93903-34380	0	P-75
90302-KBN-9000	0	P-51	91102-GW0-0090	0	P-37	93903-34380	0	P-77
90302-KED5-9000	0	P-77	91103-GR1-0040	0	P-27	93903-34380	0	P-87

零 件 號 碼 索 引

PART NO. INDEX

零 件 號 碼 PART NO.	版數 VER.	頁 次 PAGE	零 件 號 碼 PART NO.	版數 VER.	頁 次 PAGE	零 件 號 碼 PART NO.	版數 VER.	頁 次 PAGE	
93903-34380	0	P-89	95000			96001-06012-07	0	P-53	
93903-34480	0	P-77				96001-06016-08	0	P-19	
93903-35220	0	P-45		95002-02070	0	P-41	96001-06022-08	0	P-19
93903-35320	0	P-47		95002-02080	0	P-41	96001-06025-07	0	P-51
93903-35380	0	P-71		95002-02080	0	P-67	96001-06025-08	0	P-21
				95002-02100	0	P-69	96001-06025-08	0	P-35
94000				95002-50000	0	P-67	96001-06032-08	0	P-35
				95002-50000	0	P-73	96001-06045-08	0	P-33
94001-05080-0S	0	P-49		9500B-KFA6-9000	0	P-67	96001-06055-08	0	P-33
94001-12200-0S	0	P-25		9500C-KFA6-9000	0	P-67	96100-62033-00	0	P-33
94050-05080	0	P-89	95015-32001	0	P-49	96120-63010-10	0	P-61	
94050-06080	0	P-35	95015-42000	0	P-49	96211-05000	0	P-59	
94050-06080	0	P-39	95701-06012-08	0	P-91	96211-08000	0	P-59	
94050-06080	0	P-41	95701-06012-08	0	P-93	96700-KFA6-9000	0	P-83	
94050-06080	0	P-65	95701-06016-08	0	P-75				
94050-06080	0	P-67	95701-06022-07	0	P-53	98000			
94050-06080	0	P-75	95701-06025-08	0	P-15				
94050-06080	0	P-89	95701-06032-08	0	P-63	98076-5871G-00	0	P-17	
94050-06080	0	P-91	95701-06045-08	0	P-93	98200-10700	0	P-71	
94050-10080	0	P-19	95701-08012-08	0	P-35	98200-10700	0	P-91	
94050-10080	0	P-29	95701-08035-08	0	P-33				
94101-08700	0	P-83	95701-08035-08	0	P-81	D19KT			
94103-06000	0	P-93	95701-08040-08	0	P-35				
94251-08400	0	P-83	95701-08050-07	0	P-81	D19KT-001-0800	0	P-39	
94301-10200	0	P-33	95701-KEB7-E000	0	P-91	D19KT-001-1800	0	P-39	
94510-20000	0	P-31	95801-08035-08	0	P-85	D19KT-001-3800	0	P-39	
94511-14000	0	P-25	95801-08040-08	0	P-59	D19KT-001-3900	0	P-39	
94520-24000	0	P-27	95801-10035-08	0	P-85	D19KT-003-0700	0	P-39	
94591-27000	0	P-55	95801-10100-07	0	P-93	D19KT-003-1300	0	P-39	
94591-27000	0	P-75	95801-10115-07	0	P-93	D19KT-003-1500	0	P-39	
94591-KBF-9000	1	P-15				D19KT-005-1000	0	P-39	
94605-KBE-9000	1	P-97	96000			D19KT-005-1900	0	P-39	
94608-30000	0	P-97				D19KT-006-0300	0	P-39	
			96001-06012-07	0	P-19	D19KT-006-1900	0	P-39	

